

# Manual for PY74002A



## Contents

<b>1</b>	<b>General information.....</b>	<b>3</b>
1.1	Concerning the contents of this document .....	3
1.2	Intended use .....	3
1.3	Safety warnings .....	3
<b>2</b>	<b>Commissioning.....</b>	<b>4</b>
<b>3</b>	<b>Connection .....</b>	<b>8</b>
3.1	Connection cable .....	8
3.2	Pin assignment and connection diagramm.....	9
<b>4</b>	<b>Installation .....</b>	<b>10</b>
4.1	Mounting .....	10
4.2	Sensor reference levels .....	10
4.3	Measuring field definition .....	11
4.4	The reference surface.....	13
4.5	Aligning the object to be measured .....	14
4.6	Angled mounting.....	17
4.7	Installation accessories.....	18
4.8	Installation accessories.....	18
<b>5</b>	<b>Configuration .....</b>	<b>19</b>
5.1	Overview of the control elements .....	19
5.2	Function tree .....	22
5.3	LIVE MONITOR .....	23
5.4	MEAS TYP .....	25
5.5	FLEX MOUNT.....	27
5.6	OBJECT .....	32
5.7	PRECISION .....	32
5.8	FIELD OF VIEW .....	34
5.9	ANALOG OUT .....	37
5.10	DIGITAL OUT.....	38
5.11	SYSTEM .....	39
5.12	SETTING .....	41
<b>6</b>	<b>Function and definition .....</b>	<b>42</b>
6.1	Sensor data sheet.....	42
6.2	Functional principle.....	46
6.3	Measuring repetition time and response time.....	49
6.4	Object to be measured .....	50
6.5	Measuring range and positioning .....	51
6.6	Offset diameter .....	56
6.7	Interfaces and outputs .....	57
6.8	Touch panel.....	64
6.9	Memory .....	64
<b>7</b>	<b>Safety instructions and maintenance.....</b>	<b>65</b>
7.1	General safety instructions .....	65
7.2	Part identification .....	65
7.3	Influence of ambient light.....	66
7.4	Front (optics).....	66
7.5	Cleaning the sensors .....	67
7.6	Disposal .....	67
<b>8</b>	<b>Trouble shooting and tips.....</b>	<b>68</b>

8.2	Error correction .....	69
-----	------------------------	----

## 1 General information

### 1.1 Concerning the contents of this document

This manual contains information about the installation and initial setup of ipf light section sensor PY74002A. It is a supplement to the mounting instructions supplied with each sensor.



Read these operating instructions carefully and follow the safety instructions!

### 1.2 Intended use

The PY74002A sensor measures diameters and positions of round objects. It was especially developed for easy handling, flexible use, and precise measurement.

### 1.3 Safety warnings



#### NOTE

Provides helpful operation instructions or other general recommendations.



#### ATTENTION!

Indicates a possibly hazardous situation. If it is not avoided, minor or slight injuries can occur or the device can be damaged.

## 2 Commissioning

After the sensor is connected and installed, configure it via the display. The sensor is then ready for operation and outputs the measuring value in mm to the screen. Optionally, the measuring field can be limited or the switching output can be configured.

1	Connection
2	Installation
3	Application specific settings (Optional settings)
4	Let's get started

### 1 Connection

Connect the sensor according to the connection diagram. A shielded connection cable (8-pole M12) must be used.

When everything is correctly connected, the sensor starts up.

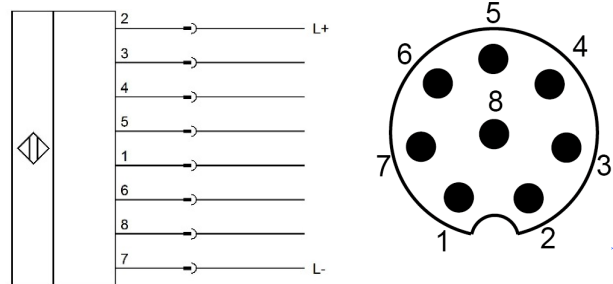

Functions: 1 = n. c., 2 = L+, 3 = 4-20mA/0-10V, 4 = push pull, 5 = alarm push pull, 6 = n. c., 7 = L-, 8 = sync in

Colors: 1 = WH (white), 2 = BN (brown), 3 = GN (green), 4 = YE (yellow), 5 = GY (gray), 6 = PK (pink), 7 = BU (blue), 8 = RD (red)

#### Key functions

- ESC = Back
- ESC 2 sec. = Run mode
- UP = Up/increase value
- DOWN = Down/decrease value
- SET = OK
- SET 2 sec. = Save value

Slide over all 4 keys:

- > = Enables the panel if locked
- <---- = Jump to run mode



#### Setting the language

The language is selected and confirmed by pressing SET for 2 seconds.

- English
- Deutsch
- Italiano
- Français

## 2 Installation

The sensor will be mounted so that the round object to be measured is covered as much as possible by the field of view.

For an angled mounting of the sensor, the reference surface will be teached-in with FLEX MOUNT. The sensor can be mounted angled with up to  $\pm 30^\circ$  to the reference surface.

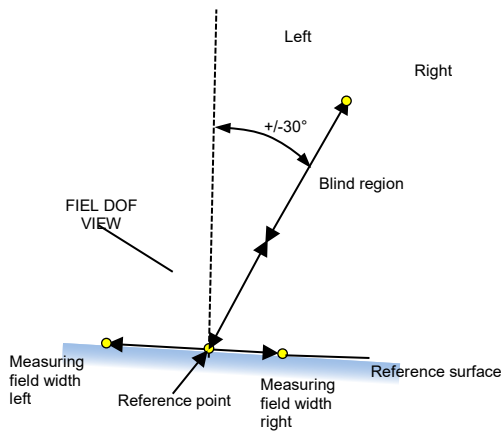

### 3 Application specific settings

The measurement type has to be selected.  
The reference (zero) is always the reference point of the sensor.

- Diameter<sup>1</sup>** = Diameter of the object
- X-Center** = Horizontal distance of the center of the object to the reference point
- Z-Center** = Vertical distance of the center of the object to the reference point
- X-Left** = Horizontal distance of the left side of the object to the reference point
- X-Right** = Horizontal distance of the right side of the object to the reference point
- Z-Top** = Vertical distance of the highest point of the object to the reference point

LIVE MONITOR	CENTER		
MEAS TYPE	Diameter X-Center Z-Center X-Left X-Right Z-Top		
FLEX MOUNT	No Yes	TEACH REF	THICKNESS REF
OBJECT	Bright Dark		
PRECISION	Standard High Very High		
FIELD OF VIEW	AUTO	LIMIT LEFT	Value in mm
		LIMIT RIGHT	Value in mm
		HEIGHT	Value in mm
		OFFSET	Value in mm
		Set max values	
ANALOG OUT	ANALOG OUT	Current / Voltage	
	CHARACTERISTIC	Pos. slope / Neg. slope	
	SCALE START	Value in mm	
	SCALE END	Value in mm	
	Set max values		
DIGITAL OUT	DIGITAL OUT	Point / Window	
	SWITCH POINT	Value in mm	
	WINDOW P1	Value in mm	
	WINDOW P2	Value in mm	
	OUTPUT LEVEL	Active high / Active low	
	Set max values		

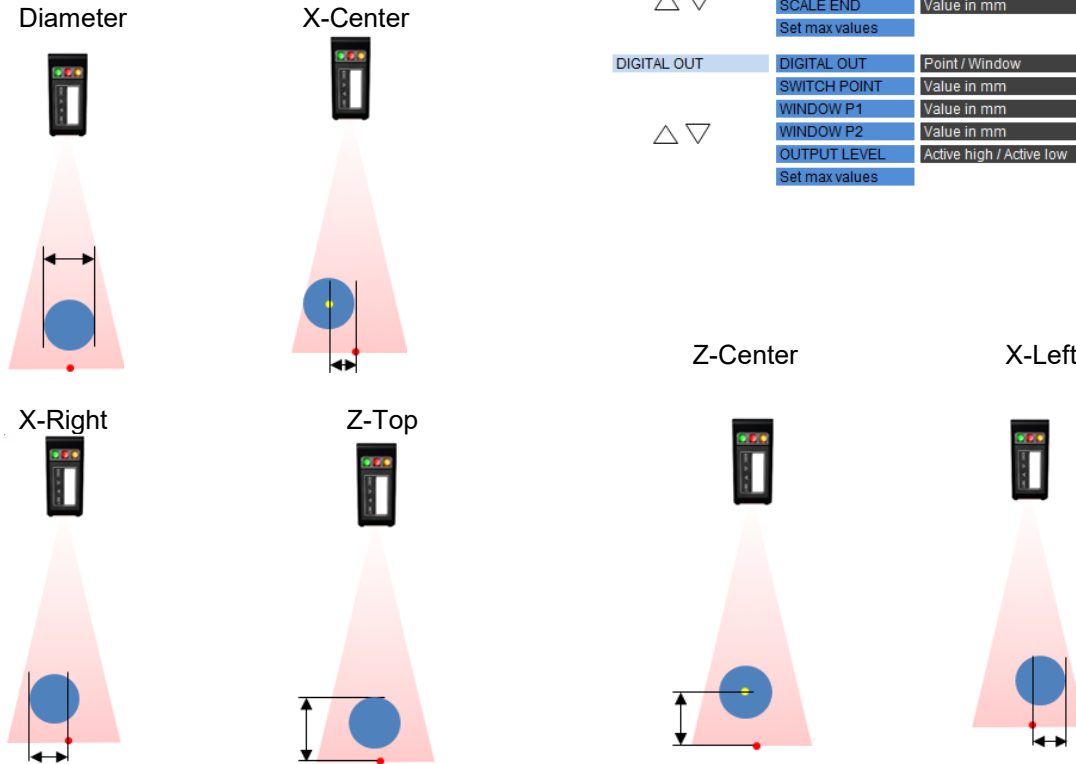

<sup>1</sup> Measuring type as factory setting

## Optional settings

### FLEX MOUNT

If the sensor is mounted at an angle, FLEX MOUNT must be activated and the reference surface taught in. *If FLEX MOUNT is activated, the following settings are reset: SCALE OUT, FIELD OF VIEW and DIGITAL OUT.*

### OBJECT

Selection of bright or dark objects to optimize the measurement results.

### PRECISION

To achieve better precision and resolution, it is possible to alternate between Standard, High and Very High by filtering the output values.

### SCALE OUT

Start of measuring range Sdc and end of measuring range Sde can be changed with SCALE OUT. 0V or 4mA then apply for the start of measuring range Sdc. 10V or 20 mA apply for the point at the end of measuring range Sde.

### FIELD OF VIEW

The width of the measuring field can be changed with FIELD OF VIEW. Separate configuration of the single points of the field: LIMIT LEFT, LIMIT RIGHT.

This function is required when there are objects in the measuring field that should not be detected.

### ANALOG OUT

The scaling of the analog output is adjustable and depends on the measuring mode. Start of measuring range Sdc can be adjusted by SCALE START, end of measuring range Sde by SCALE END. The value for the start of the output range is 0V or 4mA, for the end of the output range the value is 10V or 20mA.

Under ANALOG OUT can also be selected between voltage or current output as well as the output curve can be inverted under OUTP. SLOPE.

### DIGITAL OUT

The sensor is equipped with a switching output that can be configured as a threshold or as a window via the DIGITAL OUTPUT function.

Threshold: As soon as the measuring value is greater than the entered threshold, the switching output will be changed.

Window: As soon as the measuring value is outside the entered window, the switching output will be changed.

## 4 Let's get started

The sensor continuously outputs the measuring value in mm to the display and transmits it via the analog output to the control.

### 3 Connection

**ATTENTION!**

Incorrect supply voltage will destroy the device!

**ATTENTION!**

Connection, installation and commissioning may only be performed by qualified personnel.

**ATTENTION!**

The IP protection class is valid only if all connections are connected as described in the technical documentation.

**ATTENTION!**

Laser class 1 laser beam according to EN 60825-1:2014. This product can be operated safely without any additional safety precautions. Nevertheless direct contact between the eye and beam should be avoided.

#### 3.1 Connection cable

An 8-pole, shielded connection cable (cable socket) is required.

The connection cables with the following order codes are recommended:

- VK205A21/25 (length 2 m, M12 socket angled/straight)
- VK505A21/25 (length 5 m, M12 socket angled/straight)
- VKA05A21/25 (length 10 m, M12 socket angled/straight)

Other cable length are available.

When using the analogue output, the cable length has an influence on the signal noise. The longer the cable is, the greater the signal noise.

##### Analog output I\_OUT

Noise: 5.92  $\mu$ A (1 sigma) (10m cable and 680 ohm)  
3.59  $\mu$ A (1 sigma) (2m cable and 680 ohm)

##### Analog output U\_OUT

Noise: 4.80 mV (1 Sigma) (10m cable and 100 kOhm)  
3:03 mV (1 Sigma) (2m cable and 100 kOhm)

### 3.2 Pin assignment and connection diagram

Pin	Color	Function	Description
Pin 1	WH = white	n.c.	Not connected
Pin 2	BN = brown	+ Vs	Voltage supply (+15...+28 VDC)
Pin 3	GN = green	analog	Analog output (4...20 mA or 0...10V)
Pin 4	YE = yellow	out	Switching output, push-pull
Pin 5	GY = gray	alarm	Alarm output, push-pull
Pin 6	PK = pink	n.c.	Not connected
Pin 7	BU = blue	0V	Ground GND
Pin 8	RD = red	sync in	Input synchronization

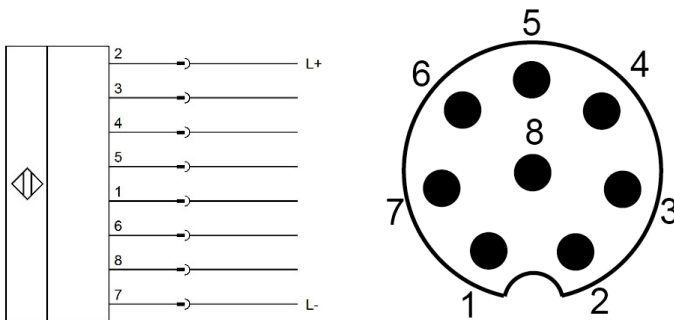

**NOTE**

It is recommended to connect unused inputs to GND (0V).

## 4 Installation



### ATTENTION!

Connection, installation and commissioning may only be performed by qualified personnel. Protect optical surfaces from moisture and dirt.

### 4.1 Mounting

The sensor has four mounting holes for flexible alignment and mounting. The use of 2 M4x35 screws is recommended for mounting. The tightening torque is max. 1.2 Nm.

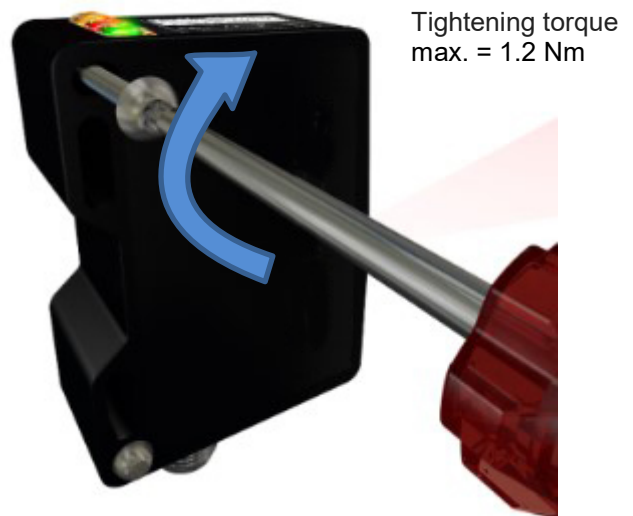

### 4.2 Sensor reference levels

To ensure easy alignment of the sensor during installation, the surfaces defined here are available: The laser beam of the sensor runs parallel ( // ) to level R3 and is at a right angle to levels R1 and R2. Levels R1, R2, and R3 serve as references for sensor alignment during installation. "Left" and "Right" designations are also important.

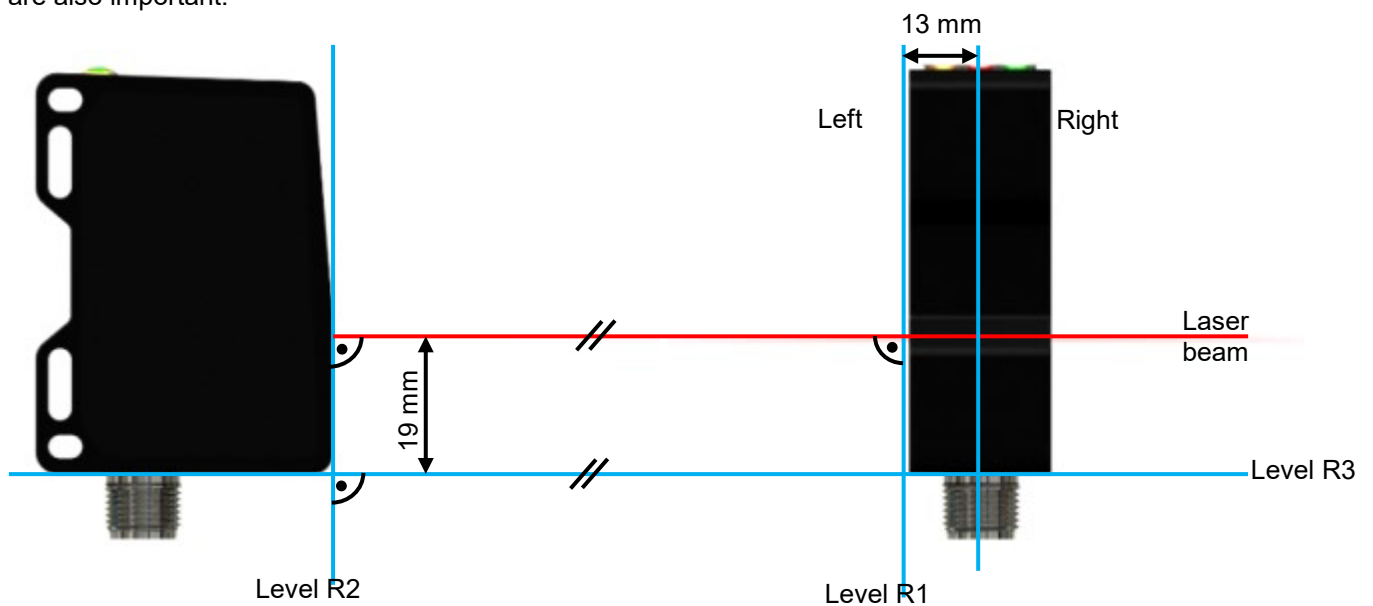

### 4.3 Measuring field definition

The maximum measuring field and additional important measuring field definitions are described in the following diagram.

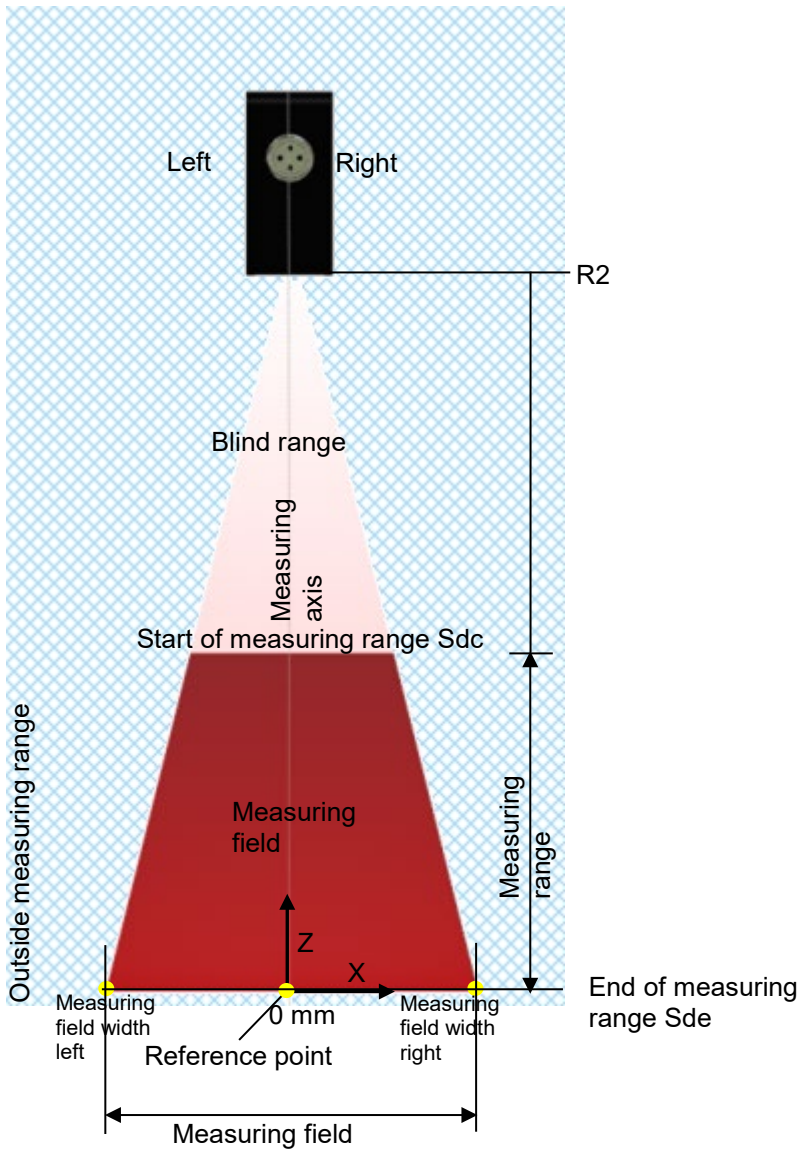

With the HEIGHT function, it is the end of measuring range Sde or optionally the teach-in reference surface (If FLEX MOUNT is active).



**NOTE**

For further explanations to the field of view, see section "Configuration" -> "FIELD OF VIEW"

#### 4.3.1 Blind region

The region from sensor level R2 up to the start of measuring range Sdc is called the blind region, i.e. the sensor cannot detect any objects there.

Objects in this area can cause incorrect measuring values.

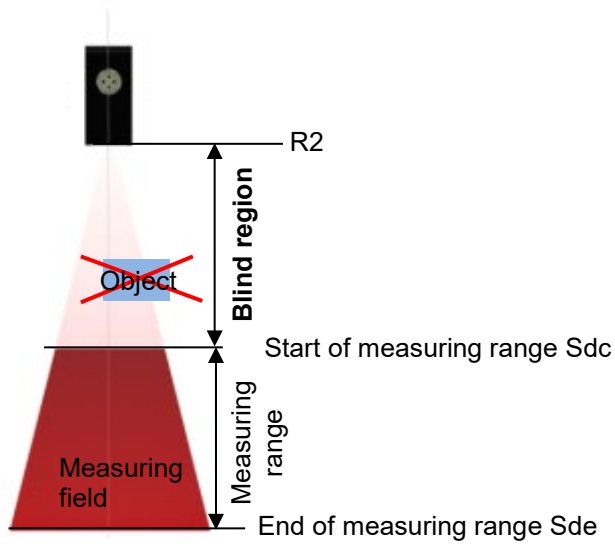

### 4.4 The reference surface

If there is no reference surface within the measuring range, the reference point of the sensor (measuring range Sde) provides the reference for all measurements.

However, when a reference surface is within the measuring range, then this should be taught-in with FLEX MOUNT. With this process, this surface now represents the reference for all measurements.

When the sensor will be mounted inclined (the angle can be up to  $\pm 30^\circ$ ), the reference surface has to be taught-in with the FLEX MOUNT function, so that the position information of the objects can be calculated correctly.

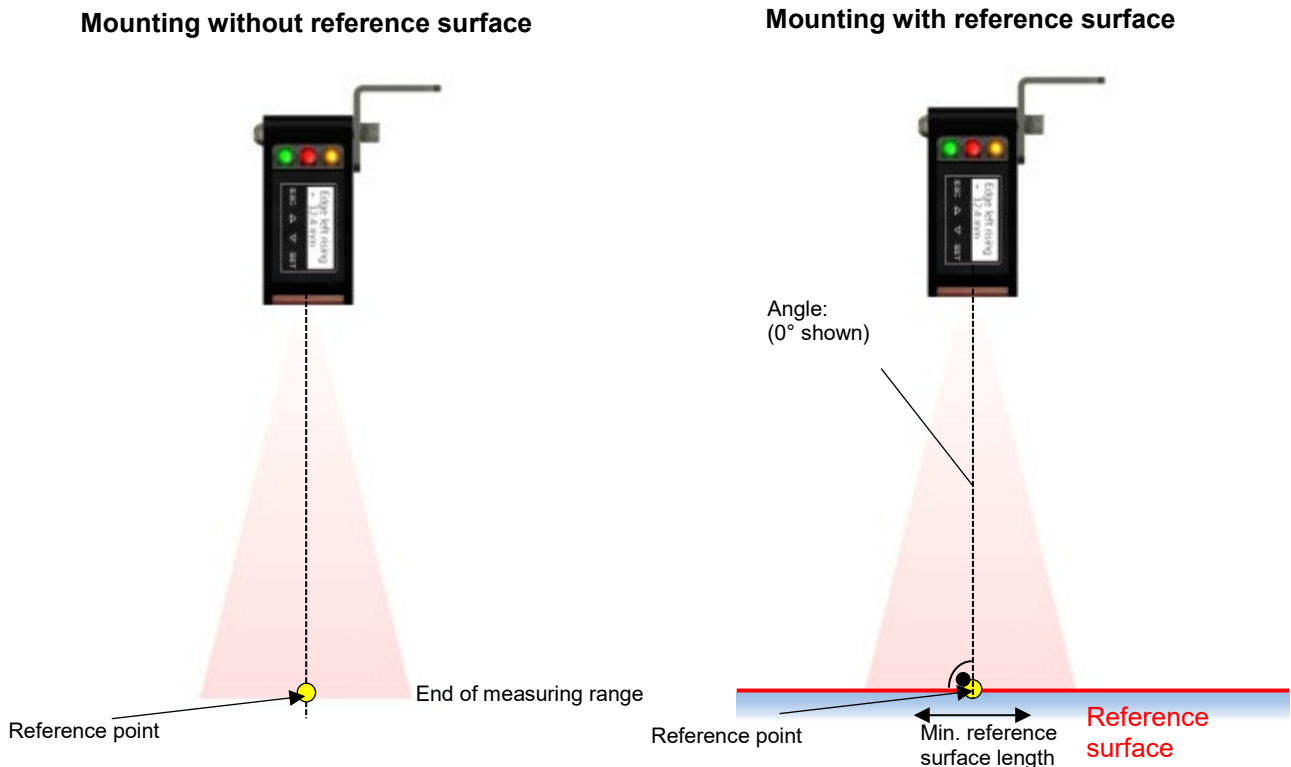

The following points must be satisfied for teaching in the reference surface:

- The reference surface must lie within the measuring range of the sensor.
- The sensor may be inclined at a maximum angle of  $\pm 30^\circ$  to the reference surface.
- The "Maximum reference surface unevenness"<sup>1</sup> must not exceed the maximum value.
- The length of the reference surface must not be less than the "minimum reference surface length"<sup>1</sup> value.

	<p><b>NOTE</b></p> <p>The reference surface...</p> <ul style="list-style-type: none"> <li>• should be as flat as possible</li> <li>• should cover the entire measuring range (width) if possible</li> <li>• can be taught-in with the FLEX MOUNT function</li> </ul>
---	--

<sup>1</sup> According to data sheet chapter 6.1

## 4.5 Aligning the object to be measured

### 4.5.1 Positioning

The object is positioned within the measuring range.

To obtain optimum measurement results, the object should be aligned at an angle as closely as possible to the sensor reference levels (Right Angle). The less precisely the object is aligned, the stronger the sensor detects an ellipse instead of a uniform circle and the less accurate the measurements.

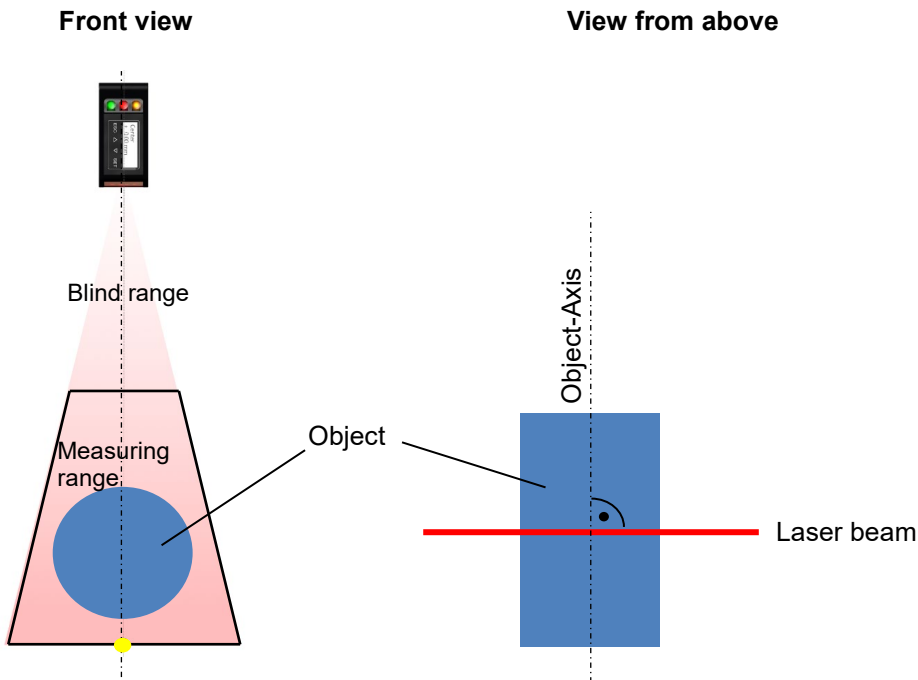

#### 4.5.2 Object not completely in the measuring range

The more measurement points are available, the more accurate the measured value can be calculated. Thus, if possible, the whole object should be within the measuring range and the object should be as centrally as possible within the lateral limits of the measuring field.

However, this is not always possible; thus, the sensor can also calculate objects, which are not entirely within the measuring range. For this purpose, minimal angle segment<sup>1</sup> of the circumferences must be covered by the laser beam.

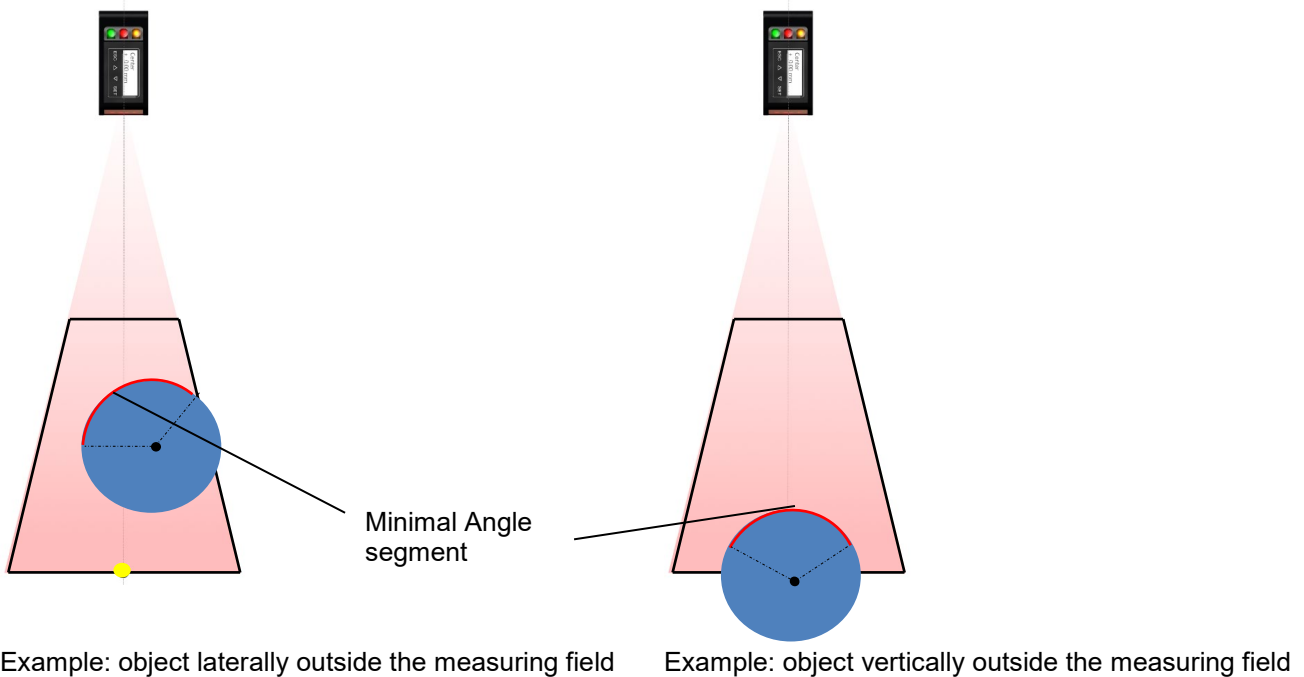

<sup>1</sup> According to data sheet chapter 6.1

**4.5.3 Possible diameter ranges**

The possible diameter ranges depend on the positioning of the sensor relative to the object. Example 1 shows an arrangement with a diameter range of 30 to 90 mm can be measured within the maximum measuring field. Larger diameters of up to 130mm can be determined by adjusting the distances from object to sensor (Examples 2 and 3).

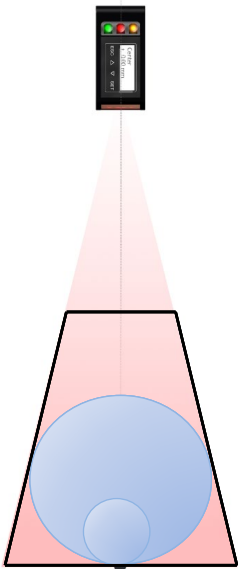

Example 1: Diameter range  
30 to 90 mm

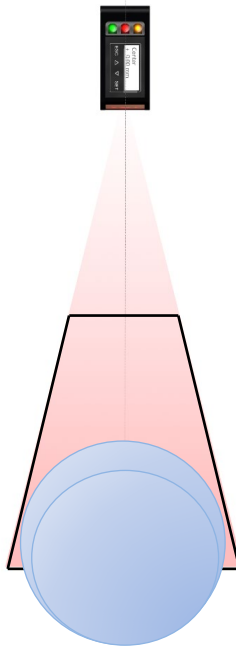

Example 2: Diameter range  
90 to 110 mm

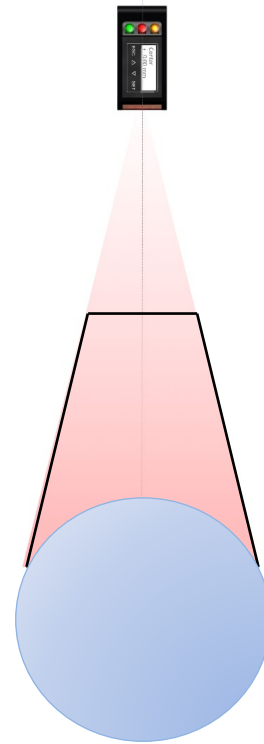

Example 3: Maximum diameter of  
130 mm

### 4.6 Angled mounting

The sensor can be installed at an inclination of up to  $\pm 30^\circ$  to the reference surface. This is particularly useful when space conditions do not allow any other installation option. See the FLEX MOUNT section. After activation of FLEX MOUNT, the sensor axis is no longer relevant. The measurement coordinate system is now represented by the M and K axes.

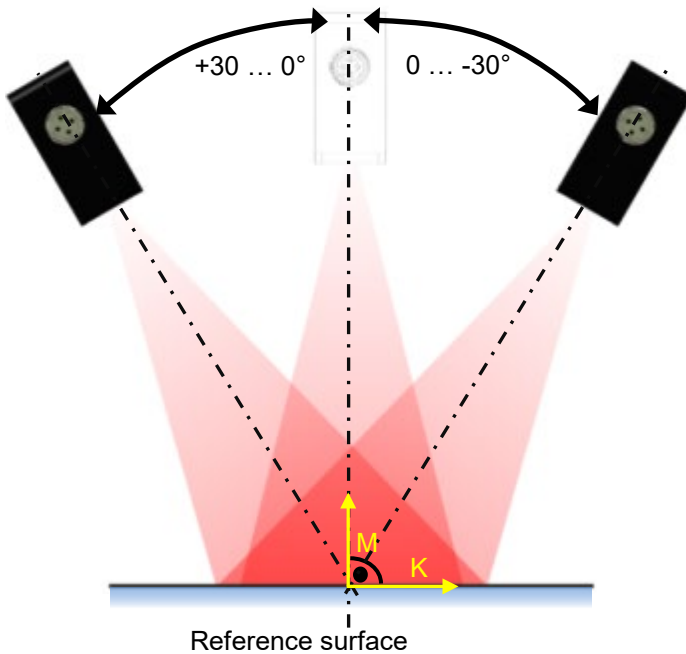

#### 4.6.1 Reference point e

In the case of angled installation, the zero point (0 mm) of the K axis shifts out of the center of the measuring field or the red visible laser line. Due to inclination of the sensor, the two measuring field sections, "measuring field width left" and "measuring field width right", are no longer equal in size. The position measurement values are always related to this reference point.

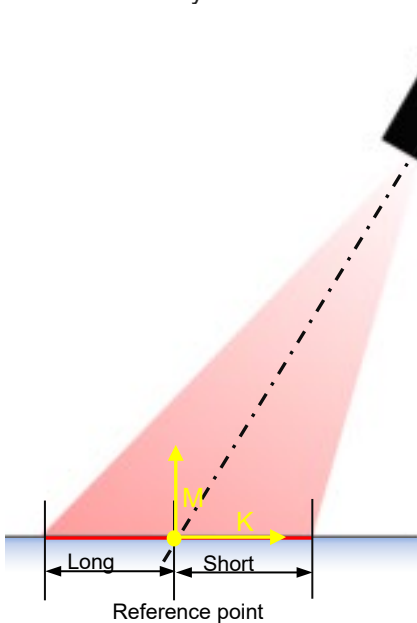

**NOTE**



This fact is relevant where the position of the reference point plays a role, e.g. with the FIELD OF VIEW function. LIMIT LEFT and LIMIT RIGHT are measured from this point.

## 4.7 Installation accessories

## 4.8 Installation accessories

To ensure optimal mounting, a mounting bracket (AP000043) is available as accessory. This bracket fits exactly with the ball-head holder AY000143.

The sensor can be shifted and adjusted inside the pivot radius of the ball-head.

### 4.8.1 Mounting kit for PY74 series

With the mounting bracket AP000043 and the ball-head module AY000143, the sensor can be mounted quickly and easily in any orientation.



## 5 Configuration

### 5.1 Overview of the control elements

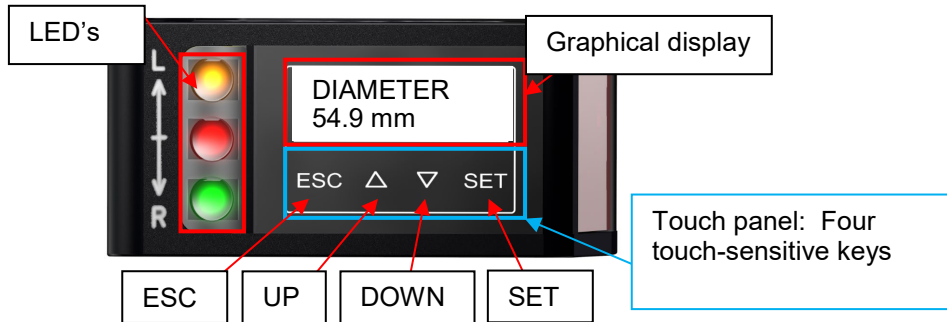

#### 5.1.1 Display modes

<b>54.9 mm</b>	<b>Run mode</b> The sensor is in run mode, the measuring value is displayed in large characters.
Diameter 54.9 mm	<b>Main menu</b> In the main menu the active mode is displayed at the top, and the measuring value is displayed at the bottom.
MEAS TYPE Diameter	<b>Scroll bar</b> The square on the right side indicates the position within the current menu. The next menu item can be accessed using the arrow keys.
MEAS TYPE Diameter	<b>Change value</b> If the function/mode at the top is displayed on a black background, the value of the bottom line can be adjusted using the UP/DOWN keys and saved with SET.
<b>OK</b>	<b>Process successful</b> The display background lights up green: Value successfully saved.
<b>FAILURE</b>	<b>Error</b> The display background lights up red: Error during the save process or wrong value entered.
	<b>Setting mode</b> When the sensor is in setting mode the display background lights up blue.
⌀ 54.9 mm	<b>Keys locked</b> If this symbol is on the left side of the screen, the touch panel is locked for operation.
◁ Diameter 54.9 mm	<b>FLEX MOUNT active</b> The angle symbol appears on the left side of the screen as soon as FLEX Mount is active.

**5.1.3 Functions of the individual keys**

Key	Pressed briefly	Pressed >2 s.
ESC	Back	Jump to Run mode
UP	Up/increase value	
DOWN	Down/decrease value	
SET	OK	Save new value*

\* Only in the setting menu when the top line is displayed on a black background (change value)

**5.1.4 Locking the touch panel**

The keys on the control panel are locked when they are not pressed for 5 minutes. A key symbol appears, and the measuring value is displayed in large lettering.

When it is pressed, the following text appears:

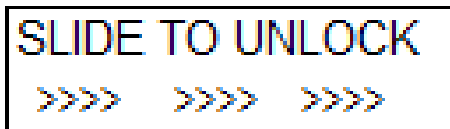

To re-enable the touch panel, it is required to quickly slide a finger over all four keys from left to right (slide over ESC, UP, DOWN, and SET).



**5.1.5 Further key functions**

Action	Reaction
Slide over all keys from left to right	<b>Unlock locked touch panel</b> Only if touch panel is locked
Slide over all keys from right to left	<b>Jump directly to run mode</b> Can be used from any menu

**5.1.6 LEDs on the sensor**

LED	Lights up	Flashes
Yellow	<b>Out1 activated</b> Switching output1 active	-
Red	<b>Out2 activated</b> No valid measuring object inside the measuring field. Alarm output active.	<b>Insufficient excess gain</b> Object close to signal gain (Not enough light). Performing setting OBJECT (Bright or Dark).
Green	<b>Supply voltage</b> Sensor ready for operation.	<b>Short circuit</b> Check connection on digital output 1 or 2.



## 5.2 Function tree

The menu that can be accessed via the touch panel is shown below.

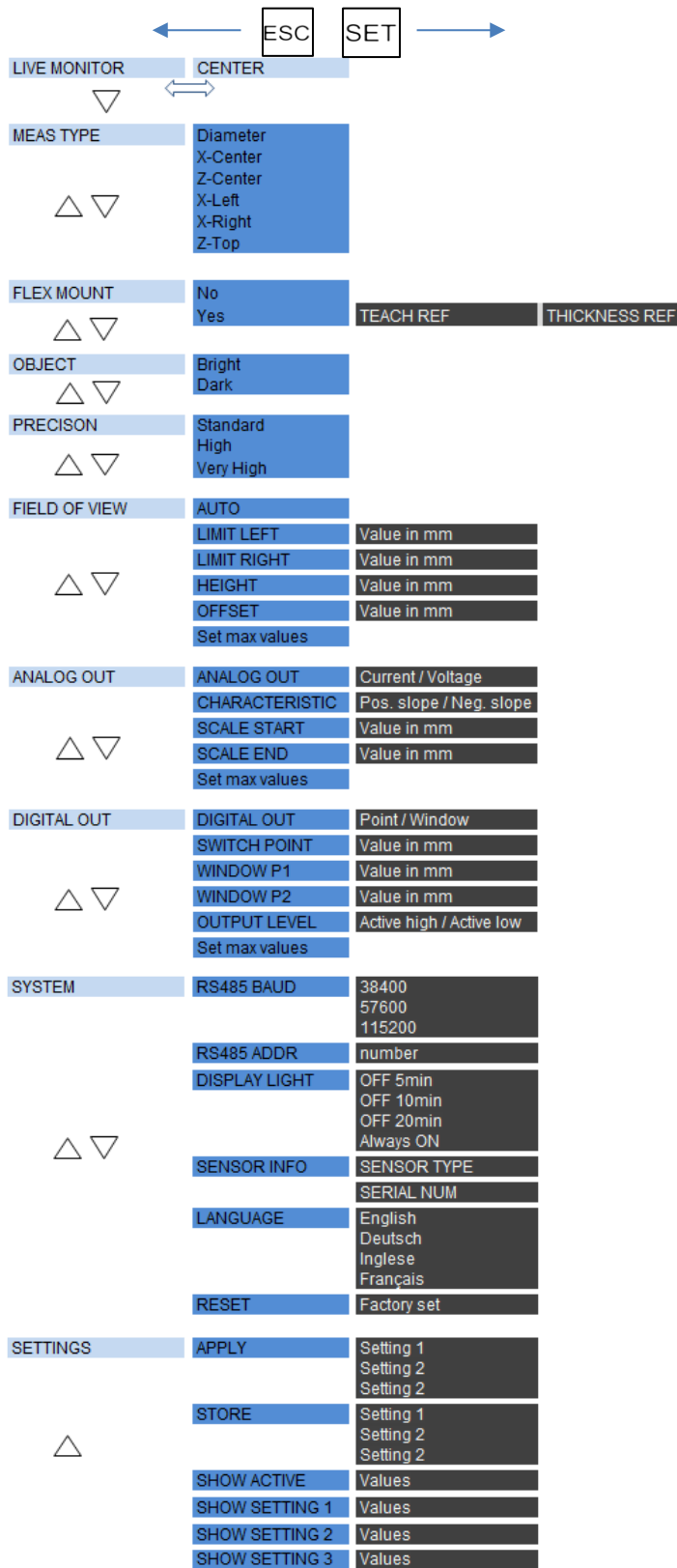

### 5.3 LIVE MONITOR

The installation conditions can be checked using the LIVE MONITOR. The sensor continuously measures the angle and the distance from the optical axis to the measuring level and outputs the values. This makes installation much easier and also points out installation errors.



Measured angle in ° to the reference surface

Distance to the reference surface

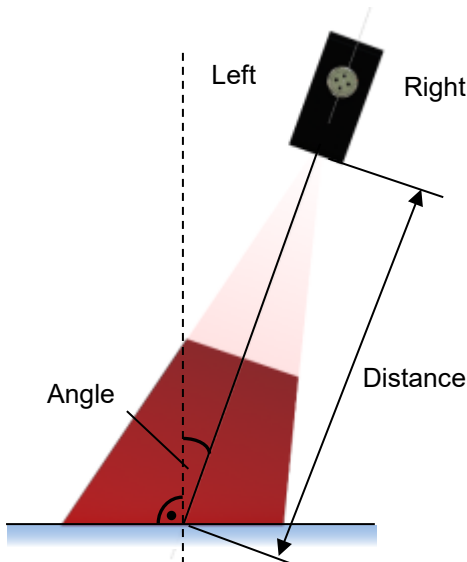

**NOTE**

An angle of 0° means that the sensor is at a right angle to the reference surface.



**NOTE**

As soon LIVE MONITOR is active, the measuring field is set to maximum and the sensors outputs are set to “no object in measuring range”. FLEX MOUNT is disabled during this time. After disabling LIVE MONITOR the last valid settings are applied again.

### 5.3.1 Center INFO

Once the sensor, while LIVE MONITOR is active, detects a round object in the measurement range, the mode CENTER INFO is automatically activated. Once there is no more round object in the measurement range, the mounting conditions in the LIVE MONITOR reappear.

The position of the object on the X and Z-axis will be displayed on the display in mode CENTER INFO. During this process the measurement field is set to maximum; the outputs of the sensor are inactive.

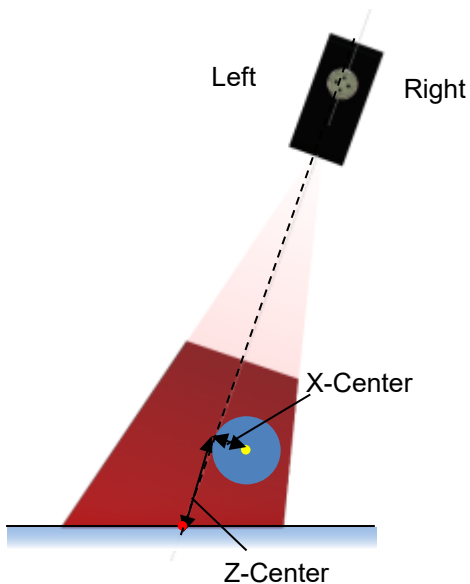
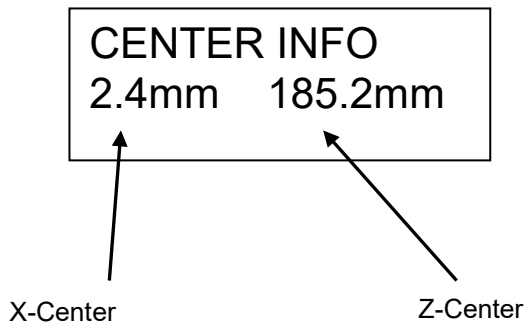

**5.4 MEAS TYP**

The PY74002A calculates the measured value according to the selected measurement type independently and **gibt diesen analog aus.**

Since unwanted foreign objects could be included in the calculation, there should only be the measured circular object in the measuring field during measurement. If this is not possible, it is recommended to limit the FIELD OF VIEW.

**5.4.1 Diameter**

Diameter of the object.

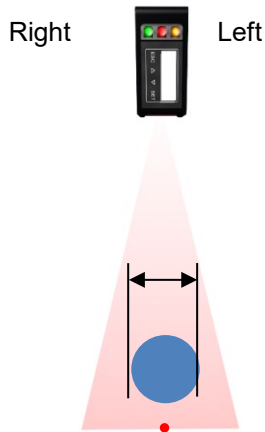

**5.4.2 Z-Top**

Vertical difference of the top point of the object to the reference point.

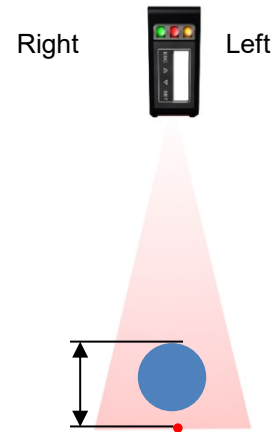

**5.4.3 X-Center**

Horizontal difference of the object center to the reference point.

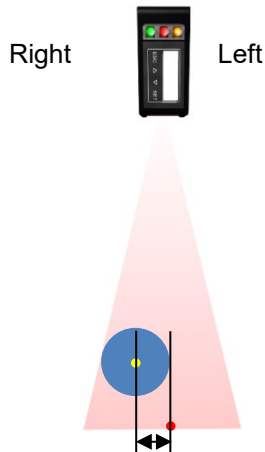

**5.4.4 Z-Center**

Vertical difference of the object center to the reference point.

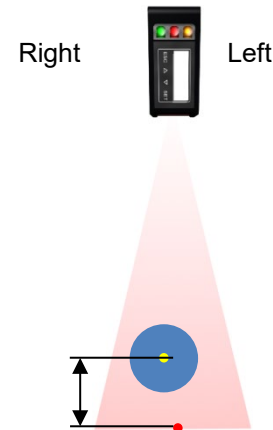

**5.4.5 X-Left**

Horizontal difference of the left side of the object to the reference point.

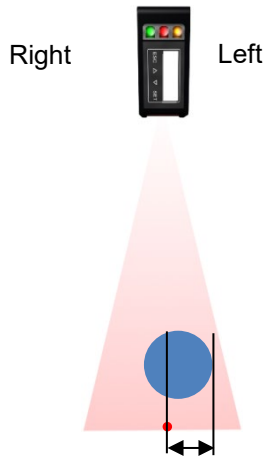
**5.4.6 X-Right**

Horizontal difference of the right side of the object to the reference point.

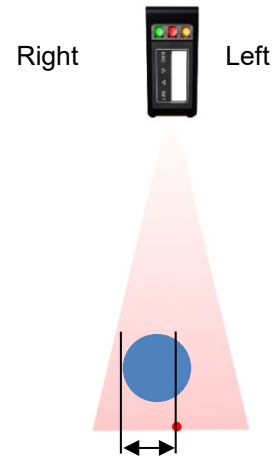
**5.4.7 Explanation to the measuring types:**

- For Z-Top the top point even applies when the sensor is mounted angled
- The round object has not to be completely located within the measuring range, see "Aligning the object to be measured"
- The calculated position values may lay outside the measuring field

**NOTE**

If the MEAS TYPE is changed, SCALE OUT and DIGITAL OUT are reset to the default setting.

## 5.5 FLEX MOUNT

With FLEX MOUNT the reference surface will be Teached-In. With respect of its inclination, the sensor is able to calculate the measurement value correctly.

For a correct calculation of the measuring values this function is recommended if the sensor is mounted angled.

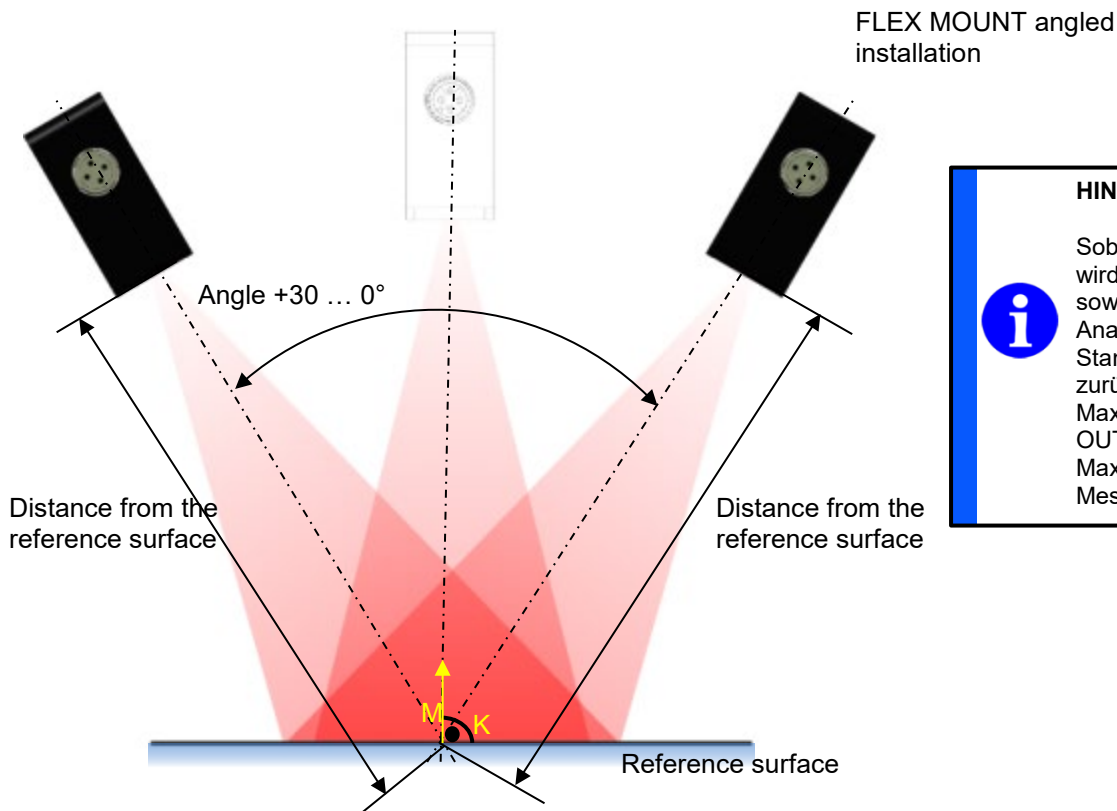

**HINWEIS**

Sobald FLEX MOUNT aktiviert wird, werden MESSFELD sowie DIGITAL OUT und Analog Out auf die Standardeinstellungen zurückgesetzt (MESSFELD = Maximales Messfeld, DIGITAL OUT und ANALOG OUT = Max. Wertebereich des Messtyps).

With FLEX MOUNT the inclination angle and the distance from the reference surface are automatically detected and saved in the sensor memory so the coordinate system can be rotated correctly. It is important that the reached surface is even and covers as much of the entire measuring range of the sensor as possible.

### FLEX MOUNT is used, if...

- a standard installation (right angle to the reference surface or the object) is not present
- the reference surface is closer to the sensor than the End of the measuring range Sde
- the reference surface is to be automatically taught in and/or shifted
- the background is to be suppressed

### Effects

- The coordinate system is rotated
- The reference surface is teached-in; the original sensor reference point is no longer valid
- Objects below the reference surface are ignored
- The axes are no longer referred to as X and Z, but as M and K
- The angle symbol  $\sphericalangle$  appears on the left of the display when FLEX MOUNT is active
- FIELD OF VIEW, ANALOG OUT and DIGITAL OUT are reset to factory settings<sup>1</sup>

<sup>1</sup> According to data sheet chapter 6.1

**5.5.1 No**

The FLEX MOUNT function is switched off by "No". If FLEX MOUNT is not activated, a 0° angle and "distance" = end of measuring range Sde<sup>1</sup> are set.

The angle symbol  disappears from the display.

**NOTE**

 As soon as FLEX MOUNT is activated, FIELD OF VIEW and DIGITAL OUT are reset to the standard settings (FIELD OF VIEW = maximum measuring field, DIGITAL OUT and ANALOG OUT= maximum value range for the measurement type).

**5.5.2 Yes**

FLEX MOUNT is activated in this menu.

Next, "Place the reference (REF)" is output by the sensor and then the sensor must be aligned to the reference surface (or the auxiliary plate if there is no reference surface). The reference surface must be within the sensor's measuring field (distance from sensor to reference surface less than distance from sensor to end of measuring range Sde). The reference surface must fulfill the requirements.

**Auxiliary plate**

To compensate for unevenness, a flat temporary auxiliary plate can be used for this process. It is placed on the reference surface during teaching-in and removed after the process.

This plate should be as flat as possible and must conform to the "minimum length of reference surface". The plate must be positioned parallel to the reference surface below it. The thickness of this plate is not important as long as it is within the measuring field of the sensor. The thickness of the auxiliary plate (thickness REF) can be removed at the end of the process.

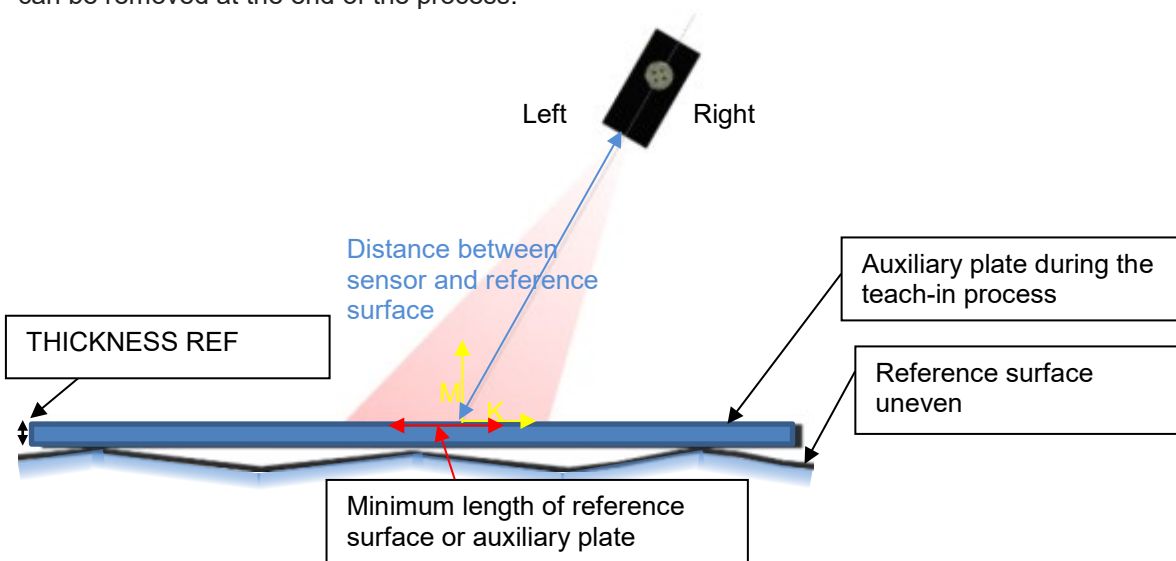

**NOTE**

 The following menu items TEACH REF and THICKNESS REF must be completed so that FLEX MOUNT can be activated.

<sup>1</sup> According to data sheet chapter 6.1

**5.5.3 TEACH REF**

**Conditions during TEACH REF**

The following four conditions must be met during the reference surface teach-in process. If one of the symbols listed below appears on the display, it lights up red. The teaching process can only begin after elimination of all errors (the display no longer lights up red).



Symbol	Error description	Error correction
	Distance between sensor and reference surface not correct. The reference surface must be within the measuring range.	Correct distance between sensor and reference surface.
	The inclination angle of the sensor to the reference surface is too large. Maximum inclination angle $\pm 30^\circ$ .	Correct inclination of the sensor.
	The reference surface is too uneven. The unevenness must not exceed the "max. reference surface unevenness" <sup>1</sup> .	Use an auxiliary plate during teach-in process.
	The length of the reference surface is too small. It must conform to the "minimum reference surface length".	Remove objects from the measuring field or use an auxiliary plate during the teach-in process.

Start the TEACH REF teach-in process by pressing SET for 2 seconds.

**NOTE**

 To ensure correct teach-in of the reference surface, THICKNESS REF must always be completed after the angle teach-in process. This is the only way to determine the effective reference surface with due regard to the thickness of the auxiliary plate.

<sup>1</sup> According to data sheet chapter 6.1

**5.5.4 THICKNESS REF**

In this menu item, the reference surface is defined with due regard to the thickness of the auxiliary plate (optional).

The surface taught in under TEACH REF is always the basis for this.

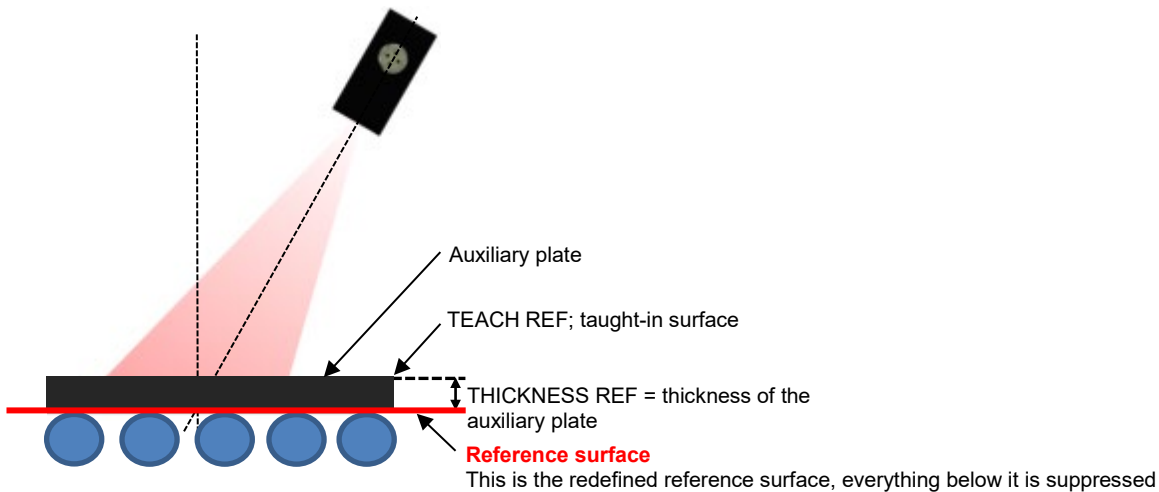

Example:

The display lights up red during TEACH REF because of unevenness in the reference surface. This reference surface does not comply with one or more conditions.

A 10 mm thick auxiliary plate is therefore placed on the reference surface for the duration of the teach-in process. Following activation of FLEX MOUNT and TEACH REF on this auxiliary plate, the auxiliary plate must be specified with 10 mm in menu item THICKNESS REF. After completion of FLEX MOUNT, the reference surface is now situated where the original (uneven) reference level was.

**NOTE**



If an auxiliary plate is not used, the item THICKNESS REF must be saved with 0 mm by pressing SET for 2 seconds.

**NOTE**



As soon as FLEX MOUNT is activated, FIELD OF VIEW, DIGITAL OUT and ANALOG OUT are reset to the standard settings (SCALE OUT and FIELD OF VIEW = maximum measuring field, DIGITAL OUT and ANALOG OUT= maximum value range for the measurement type).

### 5.5.5 FLEX MOUNT default offset

In order to increase the robustness of the measurement as well as the measuring speed, it is generally preferable to have only the measuring points desired in the measuring field as desired for the circular object. For this reason, after the Teach-in of the reference surface, the offset is automatically set up by the value "FLEX MOUNT default offset<sup>1</sup>". Everything below the new offset line is hidden, the position of the learned reference surface is not affected.

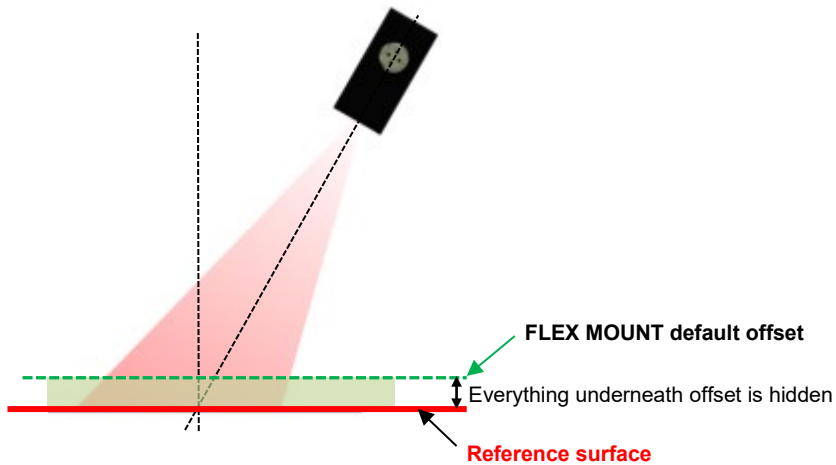

<sup>1</sup> According to data sheet chapter 6.1

## 5.6 OBJECT

To improve sensitivity to dark objects, the exposure time can be increased. This also changes the measuring repetition time.

### 5.6.1 Object: Bright (Reflectivity > 18%, white-gray)

Exposure time	Short
---------------	-------

### 5.6.2 Object: Dark (Reflectivity 6...18%, dark gray-black)

Exposure time	Long
---------------	------

## 5.7 PRECISION

By enabling filtering, the noise can be reduced and thereby the resolution can be increased.

- Standard = no filter active
- High = the noise is reduced to 25%
- Very high = the noise is reduced to 10%

### 5.7.1 Influence of the filter PRECISION

The higher precision is set, the larger are response and release time. The measuring frequency is not affected by using this filter.

PRECISION utilizes a moving median and a moving average filter.

#### Moving Median

Median (or center value) is a boundary between two halves. In the statistics, the median halves a distribution. Compared to the arithmetic mean, also called average, the median has the advantage of being more robust against outliers (extremely deviant values).

The median of a finite list of numbers can be found by arranging all the observations from lowest value to highest value and picking the middle one (e.g., the median of {3, 3, 5, 9, 11} is 5). The number of samples stored in the array is called "Sample size" (e.g. {3, 3, 5, 9, 11} = 5 values). When a new sample is added the oldest sample is removed (Moving filter). A sudden change of the measured values will only effect the output after more than half of the samples stored resemble the new value (e.g. sample size=5 -> 3 samples until output is effected).

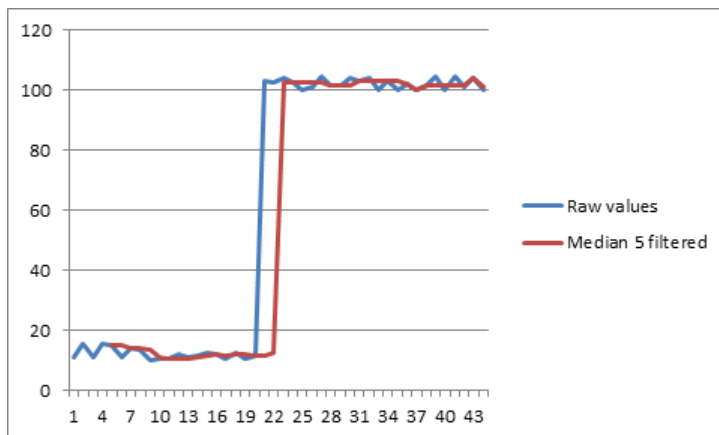

The diagram shows the effects of the median (sample size 5). The filter is used to suppress errors. The output changes after a defined number of samples (sample size/2). The measurement frequency is not affected by this filter, but rather the response time.

**Moving average**

The output of the moving average filter is the average of all values found in the array with the defined sample size. When a new sample is added, the oldest sample is removed (Moving filter).

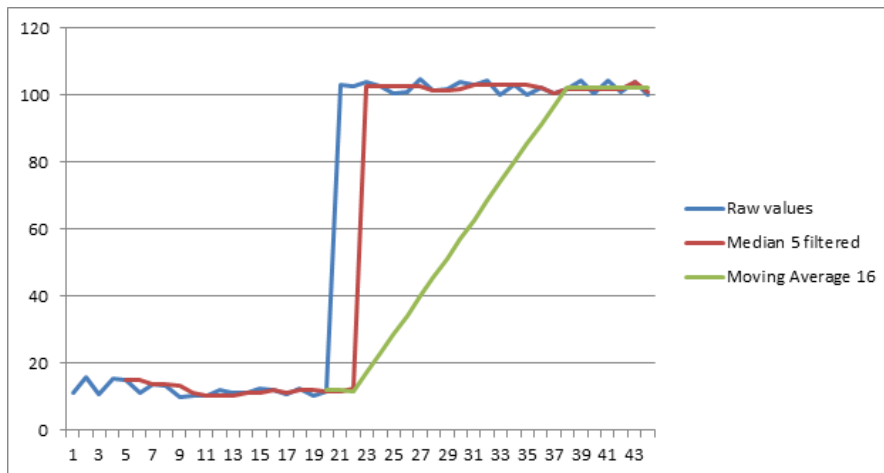

As visible in the diagram, the moving average softens the output. In contrast to the median filter, values at the output can be values that have never been measured. The measurement frequency is not affected by this filter, but rather the response time.

Number of samples until the correct value will be output:

- In PRECISION mode HIGH, the measured value has to be stable for 4 + 16 samples for the output to show the current value.
- In precision mode very high, the measured value has to be stable for 8 + 128 samples for the output to show the current value

**Example**

Calculation of the response time with measuring frequency 300 Hz, PRECISION = High

$1 / 300 \text{ Hz} = 0.0033 \text{ s}$

Median =  $7 / 2$  (Formula: Samples / 2) = 4

Average = 16

**Response time =  $0.0033 * (4 + 16) = 0.066 \text{ s} = 66 \text{ ms}$**

## 5.8 FIELD OF VIEW

The measuring field can be limited with the FIELD OF VIEW function. All measuring points outside the set measuring field are ignored. This is particularly useful if, for example, the measuring field contains an unwanted object that should not be detected.

The measuring field is adapted by software so the width of the visible laser beam does not change.

### 5.8.1 AUTO

With this function the measuring field can be limited to a rectangle. This function is particularly useful in the inclined state because the borders of the measuring field can be more easily recognized thanks to the rectangle (secured measuring field in height and width).

The maximum width is automatically calculated by entering the height; the rectangle (height and width) shown on the display is saved by pressing SET for 2 seconds.

When the rectangular measuring field is activated, the following symbol appears on the left side of the screen:



**Entering height H in mm:** The width of the rectangle is automatically set to the maximum allowable value within the measuring field.

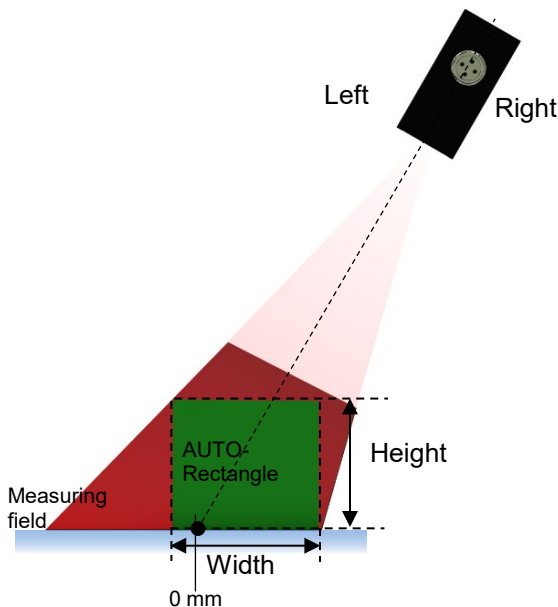

**NOTE**

The LIMIT LEFT and LIMIT RIGHT functions can be used as an aid to determine the position of the defined rectangle within the measuring field. The values of this rectangle are shown in this menu.

**NOTE**

When using AUTO, already set measurement field limitations (left, right and offset) are canceled (offset is set to default).

The limit of the maximum height and width varies on the rectangle depending on the inclination angle.

Examples with inclination angle of  $-30^\circ$

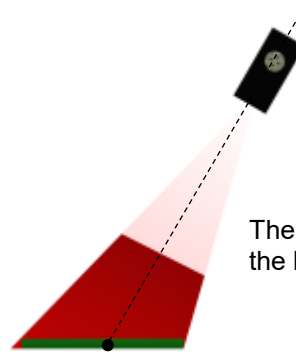
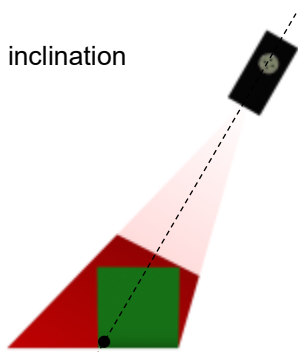

The width increases when the height is reduced

**5.8.2 Manual limitation of the measurement field**

For full flexibility, every value can be individually adjusted in the measuring field.

- LIMIT LEFT
- LIMIT RIGHT
- HEIGHT
- OFFSET

**Standard installation**

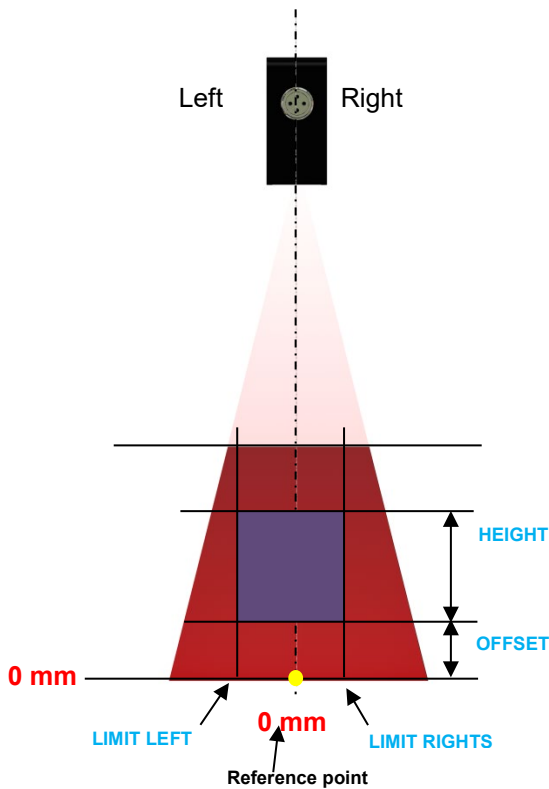

In case of standard installation (if FLEX MOUNT is not activated), the reference point of the sensor is respectively 0 (End of measuring range Sde).

**Angled installation (FLEX MOUNT)**

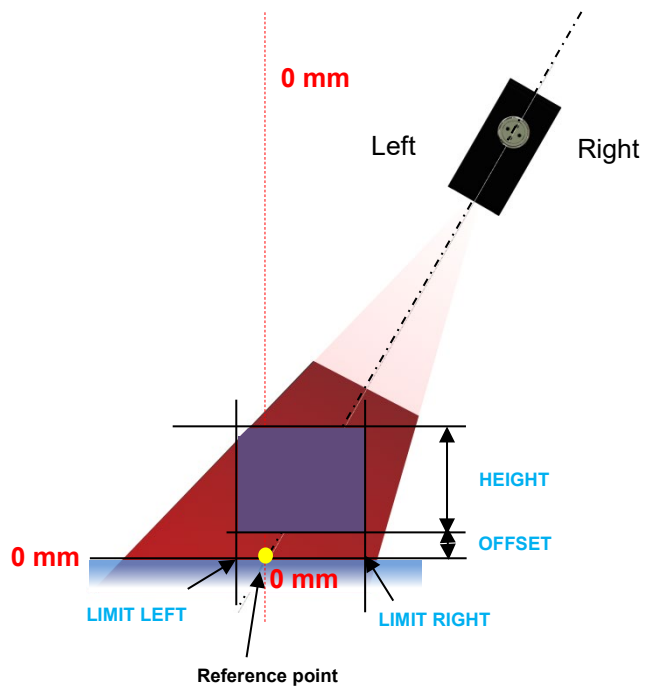

If a reference surface was taught in with FLEX MOUNT, the teached-in surface there is 0.

**NOTE**



If the measuring field is already limited with a rectangle (AUTO), the rectangle can be limited additionally using LIMIT LEFT, LIMIT RIGHT, HEIGHT and OFFSET.

**5.8.3 LIMIT LEFT**

Value measured horizontally from reference point (0 mm), to the left.  
All points to the left of this range are suppressed.

**5.8.4 LIMIT RIGHT**

Value measured horizontally from reference point (0 mm), to the right.  
All points to the right of this range are suppressed.

**5.8.5 HEIGHT**

All measuring values above HEIGHT are suppressed. HEIGHT will be measured from the reference point of the sensor in the direction of Z. When OFFSET is active, HEIGHT is indicated from this point.

**5.8.6 OFFSET**

All measuring values underneath OFFSET are suppressed. In case of standard installation, if FLEX MOUNT is not activated, the offset is measured from the sensor reference point. If FLEX MOUNT is activated, the taught-in reference surface is 0.

**NOTE**

The minimal measuring field size is defined in the chapter 6.1 „Sensor datasheet“

**5.8.7 Set to max values**

"Set to max. values" sets all adjustments of the measuring field back to the standard settings (maximum measuring field, see red area).

## 5.9 ANALOG OUT

### 5.9.1 ANALOG OUT

The analog output can be reset to voltage or current, depending on purpose.

- Current (4...20 mA)
- Voltage (0...10 V)

### 5.9.2 CHARACTERISTIC

The analog characteristic curve can be inverted. With a positive output slope, the signal increases with an increasing measuring value. For the negative slope the output signal decreases with an increasing measuring value.

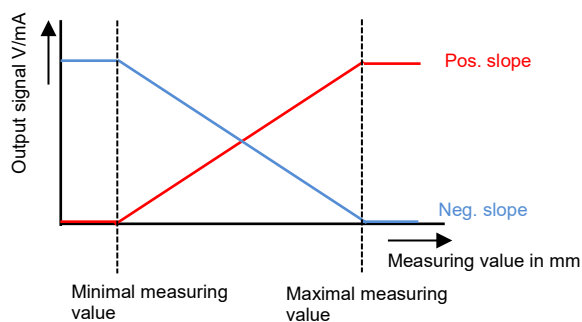

### 5.9.3 SCALE START/END

In the factory setting, the analog output runs across the entire measuring range.

The minimum measured value (SCALE START) corresponds to 0 V or 4 mA, the maximum measured value (SCALE END) 10 V or 20 mA. In this menu, the lower and upper measurement points can be changed, whereby resolution and linearity are improved.

By limiting the analog output the selected measuring field is not affected. For the minimal window size see "Sensors data sheet" in chapter 6.1.

**SCALE START:** Represents the measuring value in mm for the minimal analog output value of 0V or 4 mA (Min. diameter. or min. position).

**SCALE END:** Represents the measuring value in mm for the maximal analog output value of 10V or 20 mA. (Max. diameter or max. position).

### 5.9.4 SET MAX VALUES

SCALE OUT is reset to the standard setting (maximum measuring field) with the "set max values" command.

## 5.10 DIGITAL OUT

With Pin 4 (out), the user has a configurable switching output.

It can be defined as a single switching point (threshold) or a window. Pin 4 is activated when the value (point or window) is exceeded or not reached (active high or active low depending on the setting).

The switching points can be set depending on the selected measurement type. There is a hysteresis<sup>1</sup> for a reliable switching signal.

The window must be larger than 1 mm.

### 5.10.1 DIGITAL OUT

Whether Pin 4 is to be operated as a **threshold** (with a switch point) or as a **window** (window function) is defined here.

#### 5.10.2 Switch point

The switch point is selected in mm using the arrow keys.

The point must be between the beginning of the measurement type-specific measuring range and end of range - 2x hysteresis<sup>1</sup>.

#### 5.10.3 WINDOW P1

Window point 1 (for the WINDOW mode) is selected in mm using the arrow keys.

The point must be within the measuring range of the selected measurement type (Greater than start of measuring range + 2x hysteresis<sup>1</sup>).

#### 5.10.4 WINDOW P2

Window point 2 (for the WINDOW mode) is selected in mm using the arrow keys.

The point must be within the measuring range of the selected measurement type (Smaller than end of measuring range - 2x hysteresis<sup>1</sup>).

#### 5.10.5 LEVEL

The output level can be inverted with **active high** or **active low** here.

#### NOTE

If MEAS TYPE is changed, the switching output settings are discarded. The factory settings are restored for DIGITAL OUT and ANALOG OUT.

<sup>1</sup> According to data sheet chapter 6.1

## 5.11 SYSTEM

### 5.11.1 DISPLAY LIGHT

The display background illumination automatically switches off after the set time or remains switched on. The countdown begins as soon as the keys for an operation are locked (key symbol).

- OFF 5 min.
- OFF 10min.
- OFF 20min.
- Always ON

### 5.11.2 SENSOR INFO

The sensor type and serial number are displayed here to enable clear identification of the sensor.

- SENSOR TYPE
- SERIAL NUMBER

### 5.11.3 LANGUAGE

Language selection:

- English
- Deutsch
- Italiano
- Français

#### 5.11.4 RESET

This resets all settings in sensor parameters to the factory settings.

MEAS TYPE	= Diameter
OBJECT	= Bright
PRECISION	= Standard
FLEX MOUNT	= Not activated (standard installation)
FIELD OF VIEW	= Max. values (Offset = Standard value <sup>1</sup> )
DIGITAL OUT	= Threshold (12.5 mm, active high)
ANALOG OUT	= Current, positive slope, max. scaling range
DISPLAY LIGHT	= OFF after 5min.
LANGUAGE	= English

#### NOTE



With "Reset", the current configuration in the sensor is overwritten. However, all stored settings are deleted from the sensor memory. The factory settings will be restored.

<sup>1</sup> According to data sheet chapter 6.1

## 5.12 SETTING

The settings entered in the sensor can be applied, stored or displayed here.

### 5.12.1 APPLY

The settings saved under SAVE can be activated here.

- Setting 1
- Setting 2
- Setting 3

### 5.12.2 STORE

The settings entered in the sensor can be stored here.

Three storage spaces are available.

- Setting 1
- Setting 2
- Setting 3

### 5.12.3 SHOW

SHOW displays the setting values.

SHOW ACTIVE

Displays the active settings.

SHOW SETTING 1-3

Displays the settings stored in storage spaces 1-3

The values are displayed successively; it is possible to jump to the next value using DOWN.



MEAS TYPE  
FLEX MOUNT  
OBJECT  
LIMIT LEFT  
LIMIT RIGHT  
OFFSET  
HEIGHT  
DIGITAL OUT  
SWITCH POINT  
OUTPUT LEVEL  
ANALOG OUT  
CHARACTER.  
SCALE START  
SCALE END

## 6 Function and definition

### 6.1 Sensor data sheet

Allgemeine Daten	PY74002A
Function	Measurement types: center, diameter, limits left, right and top for round objects
Function: FLEX MOUNT	Yes
Function: FIELD OF VIEW	Yes
Smallest detectable diameter	30 mm
Largest detectable diameter	130 mm
Measuring range (distance)	150...250 mm
Start of measuring range Sdc	150
End of measuring range Sde	250
Measuring range (width)	75...125 mm
Measuring field width right @ Sde	+62.5 mm
Measuring field width left @ Sde	-62.5 mm
Blind region	0...150 mm
Measuring frequency	
– OBJECT bright (approx. 90% Refl.)	200...450 Hz <sup>12</sup>
– OBJECT dark (approx. 6% Refl.)	170...250 Hz <sup>12</sup>
Response time	
– OBJECT bright (approx. 90% Refl.)	7...15 ms <sup>12</sup>
– OBJECT dark (approx. 6% Refl.)	12...18 ms <sup>12</sup>
Resolution X-Center	10...40 µm <sup>13</sup>
Resolution Z-Center	30...90 µm <sup>13</sup>
Resolution Z-Top	10...20 µm <sup>13</sup>
Resolution Diameter	150...230 µm <sup>13</sup>
Repeat accuracy X-Center	10...20 µm <sup>134</sup>
Repeat accuracy Z-Center	20...40 µm <sup>134</sup>
Repeat accuracy Z-Top	10...20 µm <sup>134</sup>
Repeat accuracy Diameter	30...70 µm <sup>134</sup>
Linearity deviation X-Center	± 35 ... ± 60 µm <sup>135</sup>
Linearity deviation Z-Center	± 110 ... ± 180 µm <sup>135</sup>
Linearity deviation Z-Top	± 50 ... ± 100 µm <sup>135</sup>
Linearity deviation Diameter	± 150 ... ± 220 µm <sup>135</sup>
Offset Diameter	± 140 µm <sup>135</sup>
Temperature drift	± 0.05% Sde/K
PRECISION:	Median      Average
Standard	Off          Off
High	7            16
Very High	15          128
Smallest needed angle segment	≥120°
Minimum measuring field size	X = 30 mm; Z = 15 mm
Minimum window size analog output	2 mm
Laser class	1
FLEX MOUNT default offset	4 mm
Max. reference surface unevenness (rms)	0.4 mm
Min. reference surface length	50 mm

<sup>1</sup> Measurement with ipf standardized measuring equipment and targets. Measuring on 90% reflectivity (white)

<sup>2</sup> Depending on size of Field of view. Maximum performance at min. measuring field size

<sup>3</sup> Depending on object size. Min. value: object diameter 90 mm; Max. value: object diameter 30 mm

<sup>4</sup> Measurement with active filtering

<sup>5</sup> Positioning of the center of the object: Measuring field width right/left: -5 ... + 5 mm; Measuring range (distance): 206 ... 226 mm

Digital output hysteresis	1% of switch point
Power on indication	Green LED
Output indicator	Yellow LED / red LED
Light source	Red laser diode, pulsed
Setting	Touch display

Electrical data	PY74002A
Voltage supply range +Vs	15 ... 28 VDC
Max. supply current (without load)	120 mA
Output circuit	Analog
Output signal	4 ... 20 mA / 0 ... 10 VDC (adjustable)
Switching output	Push-pull
Output function	Out 1 / alarm
Output current	< 100 mA
Reverse polarity protection	Yes, Vs to GND
Short circuit protection	Yes

Mechanical data	PY74002A
Width / Height / Length	26 / 74 / 55 mm
Design	Rectangular, front view
Housing material	Aluminum
Front (optics)	Glass
Connection method	Plug M12 8-pole
Weight	130 g

Ambient conditions	PY74002A
Ambient light immunity	< 25 kLux
Operating temperature	-10 ... +50 ° C
Storage temperature	-25...+75 ° C
Protection class	IP 67
Vibration resistance (sinusoidal)	<b>IEC 60068-2-6:2008</b> 7.5mm p-p for f = 2 - 8Hz 2g for f = 8 - 200Hz, or 4g for 200 - 500Hz
Resonance test	<b>IEC 60068-2-6:2008</b> 1.5mm p-p for f = 10 - 57Hz , 10 cycles for each axis 10g for f = 58 -2,000Hz, 10 cycles for each axis
Vibration resistance (random)	<b>IEC 60068-2-64:2008</b> Spectrum: 0.1 g <sup>2</sup> /Hz for 20 - 1,000Hz, 30 minutes / axis (>10g RMS)
Shock resistance	<b>IEC 60068-2-27:2009</b> 50g / 11ms or 100g / 6ms, 10 shocks in each axis and each direction 50g / 11ms or 100g / 6ms, 5,000 shocks in each axis and each direction
Impact resistance	<b>IEC 60068-2-27</b> 50g / 11ms or 100g / 6ms, 4,000 shocks in each axis and each direction

Optical properties	PY74002A
Light source	AlGaInP-Laser Diode
Wavelength	656 nm
Operational mode	pulsed
Pulse duration	
dark mode	2.4 ms
bright mode	0.6 ms
Pulse period	
Dark mode	>5.7 ms

Bright mode	>4.0 ms
Total emitted pulse power	3 mW
Beam shape	elliptical (focused to laser line)
Focus distance $d_f$	200 mm
Beam size @ exit window perpendicular parallel	3 mm 8 mm
Beam size @ focus perpendicular parallel	< 0.4 mm $L = 125 \text{ mm}$
Beam divergence perpendicular $\delta_{\perp}$ parallel $\delta_{\parallel}$	9 mrad $29^\circ$
Nominal ocular hazard distance (NOHD) <sup>1</sup>	NA
Laser classification (per IEC 60825-1/2014)	Laser Class 1

### 6.1.1 Beam divergence

Perpendicular plane:

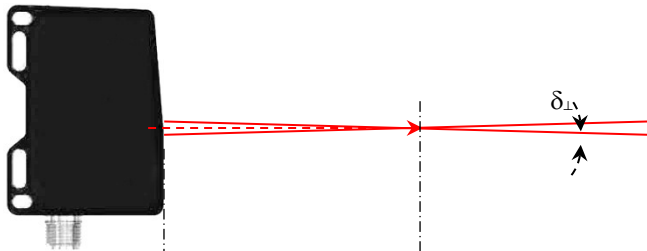

Parallel plane:

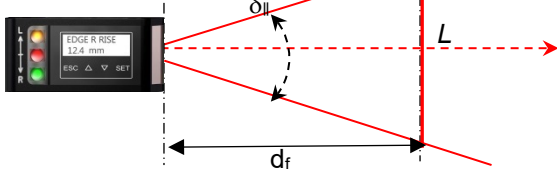

<sup>1</sup> Beyond the nominal ocular hazard distance, the accessible radiation exposure is below the limit of laser class 1

6.1.2 Dimensions

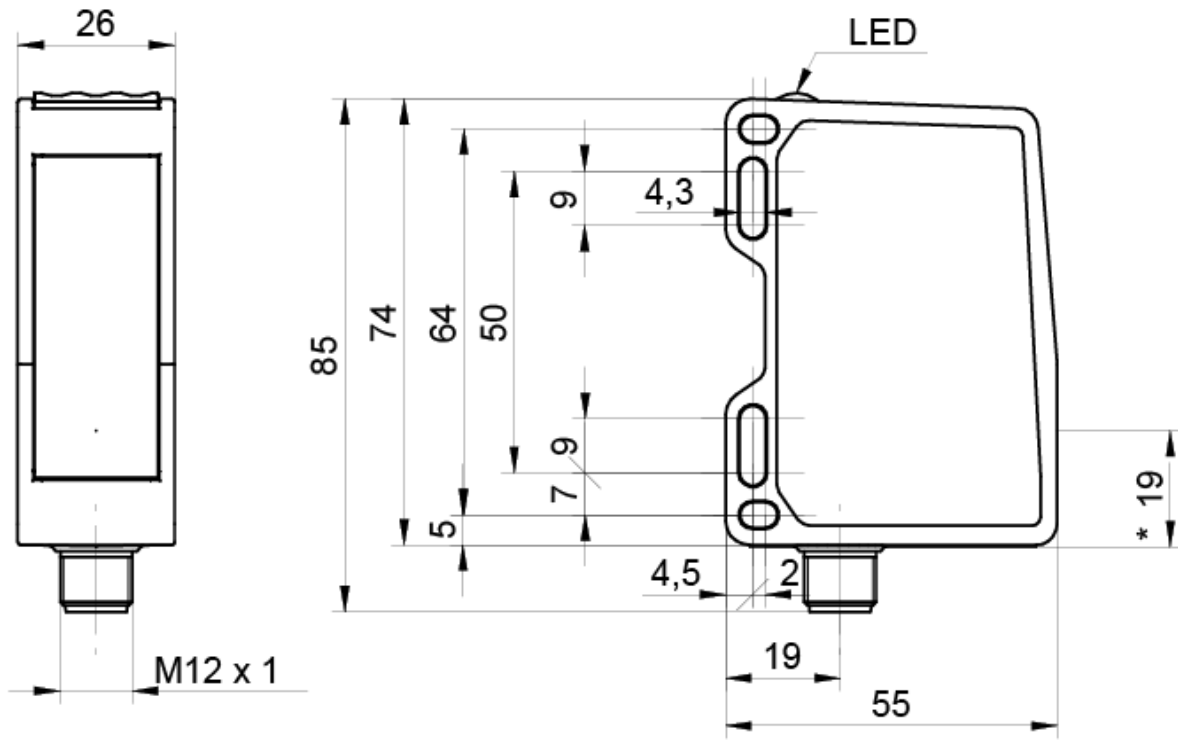

\*Optical axis

## 6.2 Functional principle

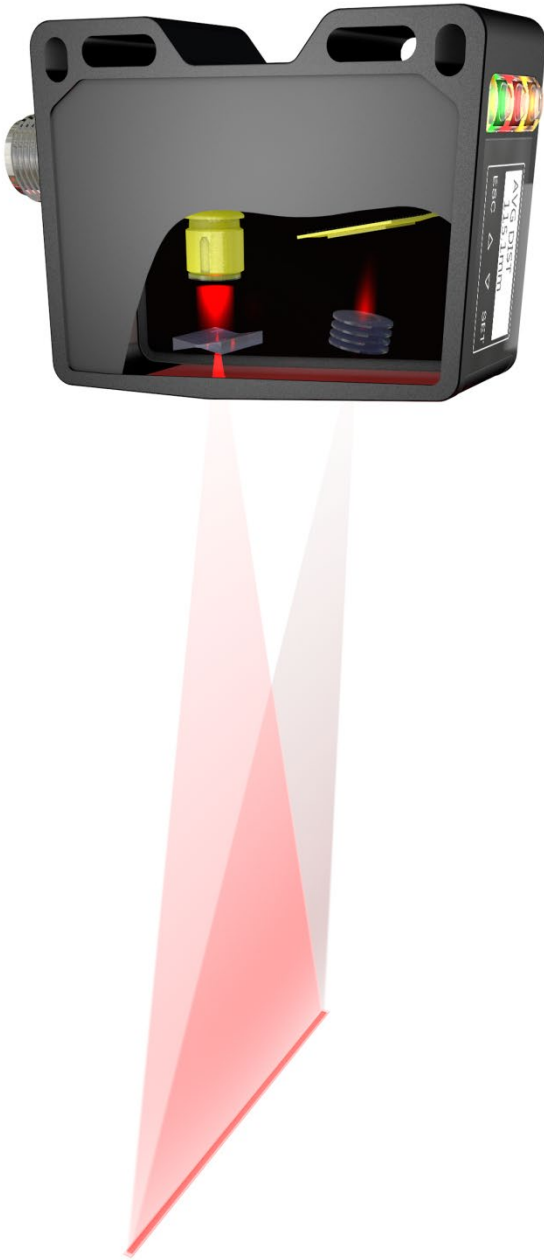

The sensor operates in accordance with the laser triangulation principle. By means of special optics, a laser beam is enlarged into a line and projected to the surface of the object to be measured. Using the multi-lens system, the reflected light from this laser line is projected onto a matrix. From this matrix image, a controller calculates the distance to every individual measuring point. The measuring value is calculated in accordance with the selected function. Thanks to the new technology, the measuring value is always output correctly, independent of the object's position in the measuring field.

### 6.2.1 qTarget

The measuring field is aligned with the housing reference surfaces at the factory. The beam position in every sensor is in exactly the same spot, which makes planning and sensor replacement very easy.

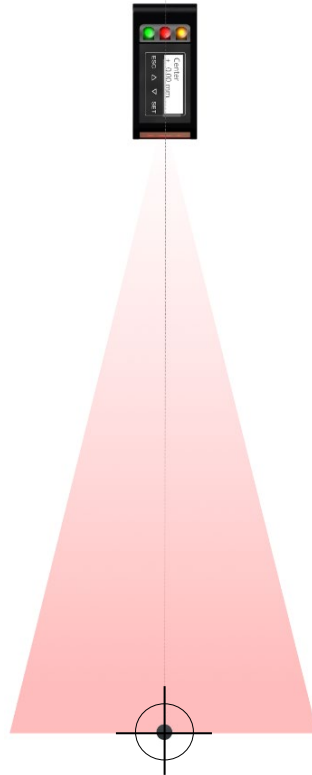

**6.2.2 Automatic object detection**

An intelligent algorithm evaluates all measuring points in the sensor and automatically detects the circular object as soon as it is in the measuring range. The measured value of the circular object is internal converted to an output signal mm.

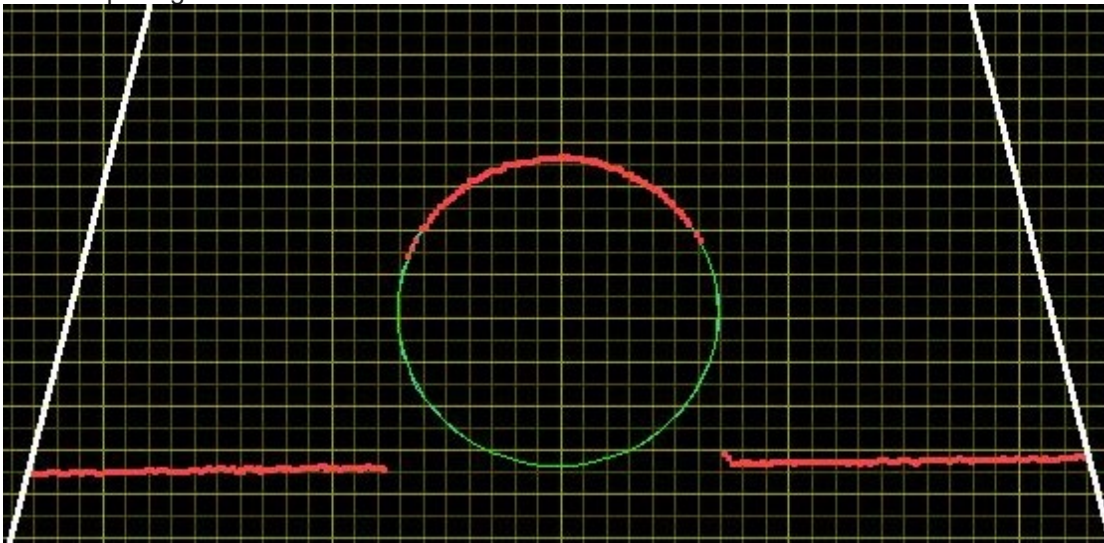

**Figure 1: The circular object was detected in the measuring range (green)**

If several circular objects are in the measuring range, then the most reliable object (Object with the lowest error indicator - usually the largest object) is output. Only a single circular object can be output at a time.

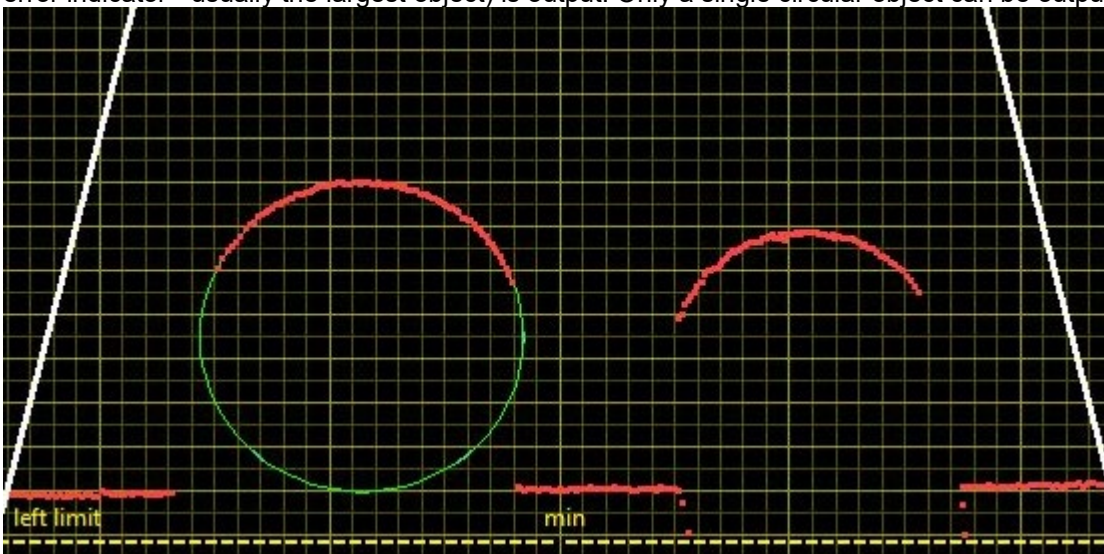

**Figure 2: Two circular objects in the measuring range**

**NOTE**



In order to obtain a reliable measured value of the desired object, it is not recommended to place more than one object in the active measuring field.

### 6.3 Measuring repetition time and response time

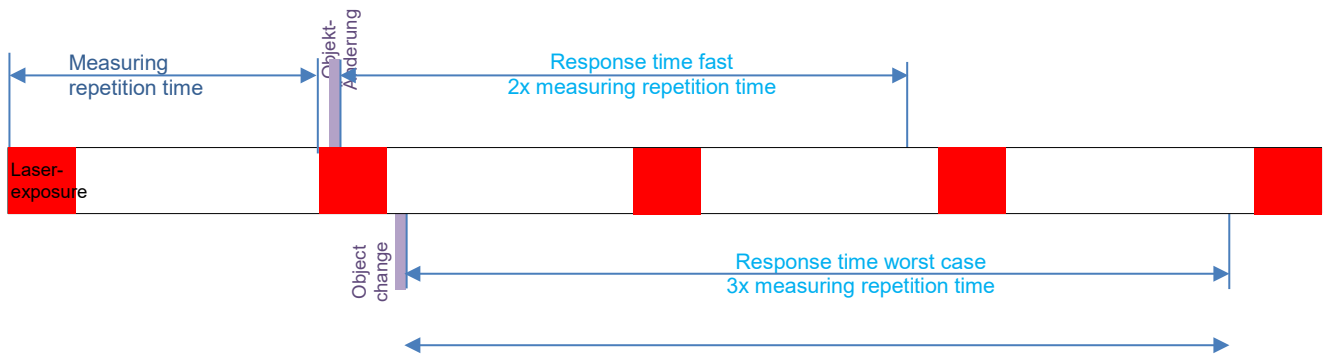

#### 6.3.1 Messwiederholzeit

The measuring repetition time (specified in milliseconds) is the time between two exposure times.

Measuring repetition time = 1/Measuring frequency in Hz'

*Example:*

Measuring frequency = 100 Hz

1/100 Hz = 0.01 s

Measuring repetition time = 0.01s

#### 6.3.2 Response time

Response time is called the time in which the sensor has output the new measured value after an object changed his position (for example).

Typically it is about 2-3x measuring repetition time.

When the position of the object has changed during the exposure time, the response time is the fastest, ie about the 2x measuring repetition time.

At the worst case, if the object position has changed shortly after an exposure time, the response time is 3x measuring repetition time.

#### 6.3.3 Response time when using Sync-In

If the Sync-In input is High, and then to start a measurement, is set to Low, the sensor starts with the exposure process.

This means that if the Sync-In is in use, the response time always is 2x the measuring repetition time.

## 6.4 Object to be measured

### 6.4.1 Requirements for the object to be measured

For an object to be reliably detected, it must conform to the minimum requirements.

- Round object
- Observe the minimum and maximum object diameter<sup>1</sup>
- As bright and matt as possible
- Not reflecting

### 6.4.2 Reflectivity

Bright objects are generally easier to detect than dark objects, since they are more reflective. Reflectivity is the percentage relationship between incident and reflected light.

#### Definition of objects:

White object	Approx. 90% reflectivity
Black object	Approx. 6% reflectivity
Bright object	> 18% reflectivity
Dark object	6...18% reflectivity

### 6.4.3 Standard object

The technical data for sensors in the data sheet refers to measurements with ipf standard objects. These standard objects are precisely defined in size, shape and color, making multiple measurements comparable.

Standard object definition:

- White Optoceramics (reflectivity approx. 90%)
- Smooth, flat surface
- Objects form support points which cover together the range of the sensor

---

<sup>1</sup> According to data sheet chapter 6.1

## 6.5 Measuring range and positioning

The effective measuring ranges for the various measurements resulting from the size of the objects and their distance to the sensor.

The requirement for an evaluable angular segment of at least 120 ° leads to effectively usable measurement fields for diameter and center point values as shown here:

### 6.5.1 Object completely within the measurement range

The best measurement accuracy can be achieved when the object is completely in the measurement field with its semicircle (180°).

#### Limits of object positions

The larger the diameter of the object, the smaller the possible change in position within the measuring field. The graph shows the possibilities of movement of the object to be identified, so that it is always located completely within the measuring range. Green shows the possible positions of the object center.

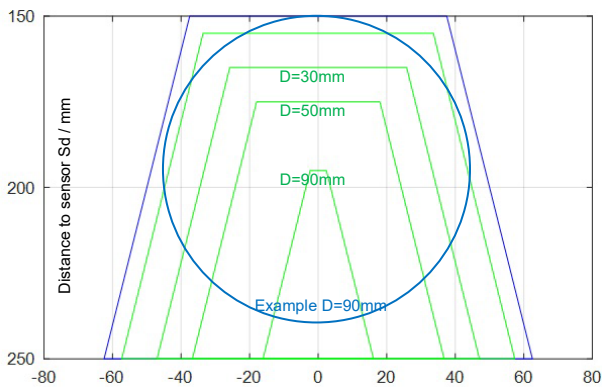

Limits of “object completely within the measuring range”

Diameter D / mm	Min. distance to sensor Sd1 / mm	width@Sd1 / mm	Max. distance to sensor Sd2 / mm	Width@Sd2 / mm
30	165.0	51.6	250.0	94.1
50	175.0	36.0	250.0	73.5
90	195.0	4.7	250.0	32.2

**6.5.2 Object not completely in the measuring range**

The object is not completely in the measuring range with its semicircle, but at least 120 ° of the angular segment is covered. Because the object is not entirely within the measuring range, larger object-diameters are possible.

**Limits of object positions**

The larger the diameter of the object, the smaller the possible change in position within the measuring field. The graph shows the possibilities of movement of the object to be identified, so that the minimum angle range is always in the measuring range. Green shows the possible positions of the object center.

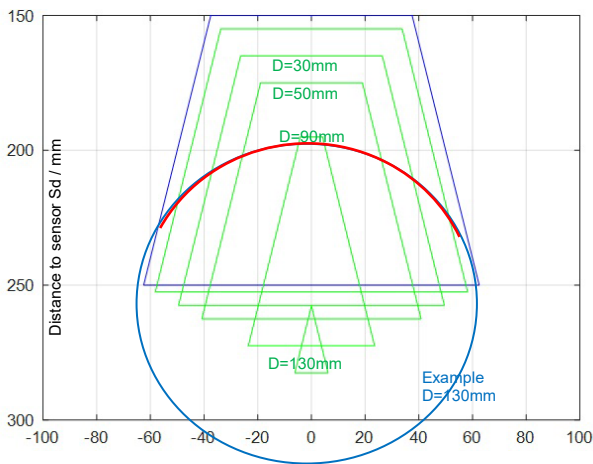

Limits of “object not completely within the measuring range”

Diameter D / mm	Min. distance to sensor Sd1 / mm	width@Sd1 / mm	Max. distance to sensor Sd2 / mm	Width@Sd2 / mm
30	165.0	52.8	257.5	99.0
50	175.0	37.9	262.5	81.7
90	195.0	8.3	272.5	47.1
130	257.7	0.0	282.5	12.4

**Maximum available measuring range for each measurement type**

Diameter	25 mm	135 mm
X-Center	-51.7mm	+51.7mm
Z-Center	33.8mm	+87.5mm
X-Right	-39.2mm	+71.5mm
X-Left	-71.5mm	+39.2mm
Z-Top	+6.3mm	+100.0mm

**Calculation of the measurement fields**

The limits of the effective spot sizes can be determined using the following formulas:

$$\begin{aligned}
 R &= D/2 \\
 Sd1 &= \text{MAX}(4 \cdot R \cdot (\text{SQRT}(3)/2 + 1/8); 150 + R) \\
 \text{width@Sd1} &= (Sd1)/2 - 2 \cdot R \cdot (\text{SQRT}(3)/2 + 1/8) \\
 Sd2 &= R/2 + 250 \\
 \text{width@Sd2} &= (Sd2)/2 - 2 \cdot R \cdot (\text{SQRT}(3)/2 + 1/8)
 \end{aligned}$$

**NOTE**



It should be noted that objects with reflective or less reflective surfaces result in smaller usable ranges.

**6.5.3 Positioning of the object**

For optimum results, the center of the object should be within the range shown in the graphic below.

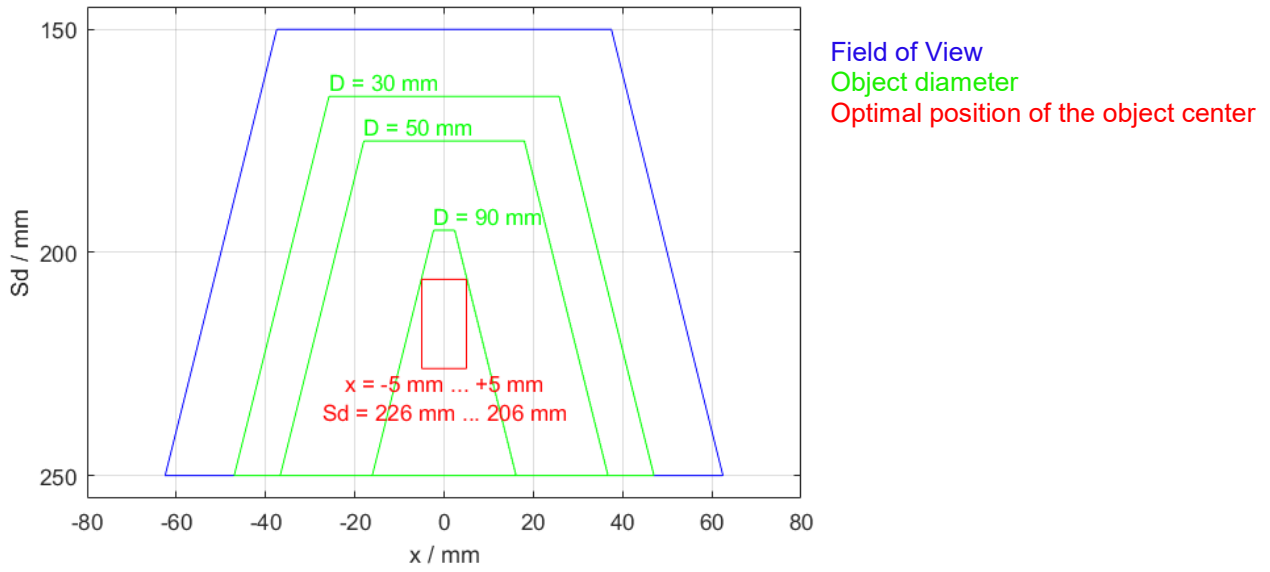

**6.5.4 Influence of angular misalignments**

The object should be aligned as accurately as possible in a right angle to the sensor. If the angles Alpha and Beta are not correct, measurement errors caused by elliptical distortion of the circular profile are the result. These deviations are specified in following diagram in % of the target measured value.

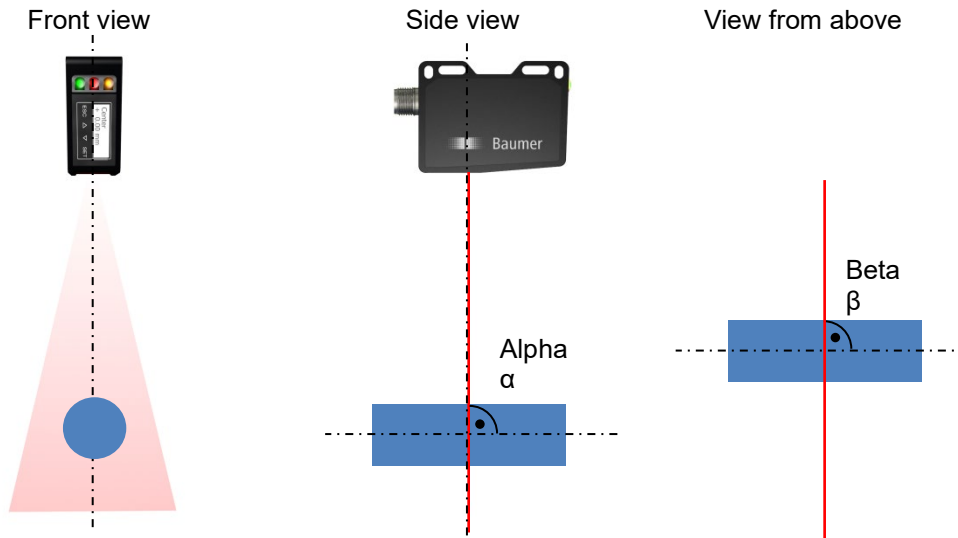

Relative deviations with angular misalignments

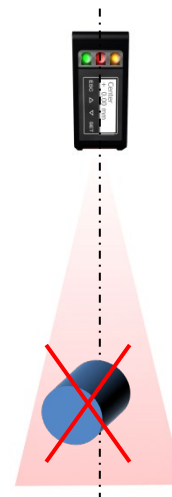
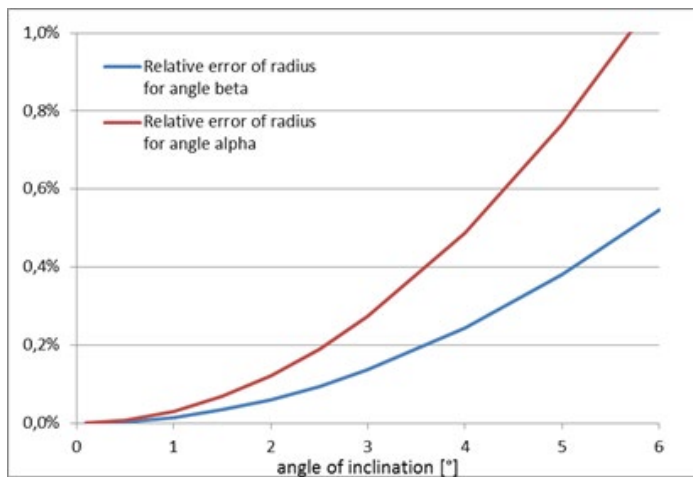

### 6.6 Offset diameter

Depending on the position of the object within the measuring field, deviations of the measured diameter value to the true value of the diameter can result.

These deviations are made up of the basic offset "Offset Diameter" as well as the linearity deviation depending on the object position "Linearity Deviation Diameter".

If the value "Offset Diameter" is positive, an excessively to high measured value is delivered, with a negative offset the value is too low.

The maximum deviation from the offset is indicated in the data sheet by the linearity deviation of the diameter across the measuring field. D is constant and the position (x and z) is variable.

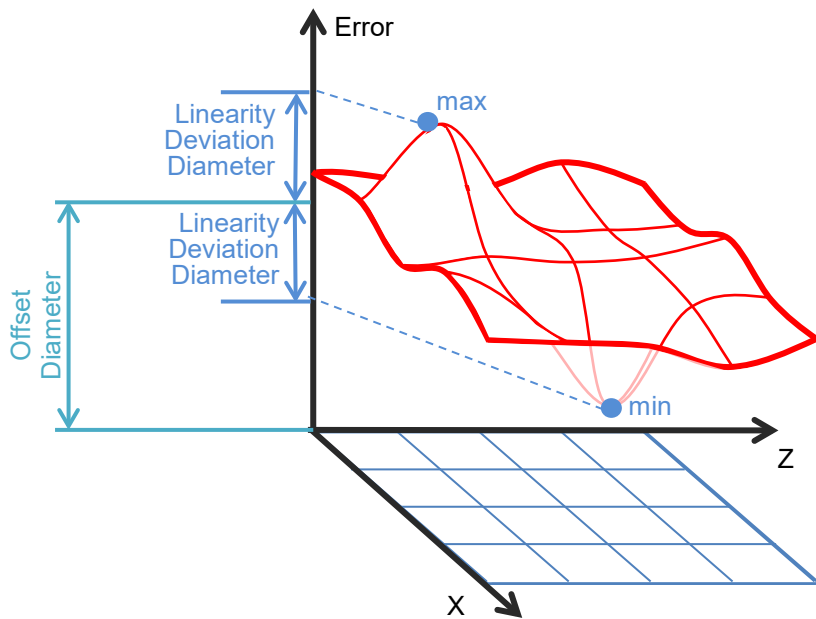

## 6.7 Interfaces and outputs

The PY74002A provides digital and analog outputs, as well as a sync-in.

- Analog output
- Synchronization
- Switching output
- Alarm output

### 6.7.1 Analog output



#### 6.7.1.1 Current or voltage output

The sensor has an analog output, which can output the signal in the form of current or voltage via the same pin.

The desired output function current or voltage can be activated in the settings of the sensor ANALOG OUT.

#### 6.7.1.2 Behavior of the analog output

Behavior of the analog output curve at default (Positive Gradient)

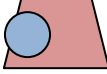
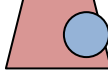
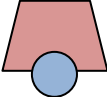
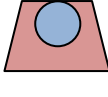
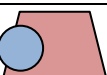
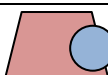
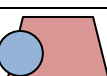
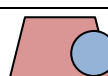
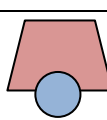
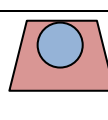
Measuring type	SCALE START		SCALE END	
		0V/4mA		10V/20mA
Diameter	Small		Big	
X-Center	Left		Right	
Z-Center	Low		High	
X-Left	Left		Right	
X-Right	Left		Right	
Z-Top	Low		High	

**NOTE**



If the object leaves the measuring range, the analog output will hold the last valid condition.

**6.7.1.3 Formulas to convert the analog signal**

The measured values in mm can be converted into an analog output signal with the following formulas. If the measuring range have been limited, so the effect is to be considered on the value ranges of the objects.

**Definitions function diameter**

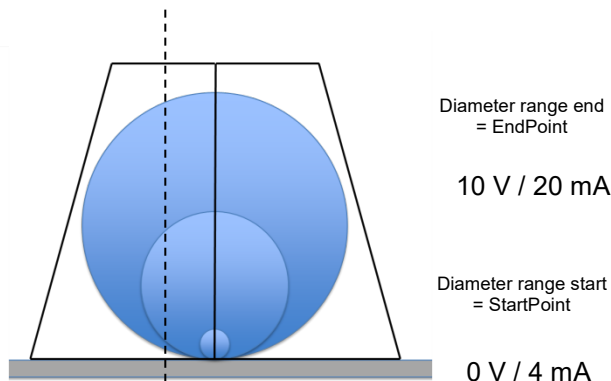

$$\text{Measuring value in V} = \frac{\text{Measuring value in mm} - \text{StartPoint}}{\text{EndPoint} - \text{StartPoint}} * 10V$$

$$\text{Measuring value in mA} = \frac{16 \text{ mA} * (\text{Measuring value in mm} - \text{StartPoint})}{\text{EndPoint} - \text{StartPoint}} + 4 \text{ mA}$$

$$\text{Measuring value in mm} = \frac{\text{Measuring value in mA} * (\text{EndPoint} - \text{StartPoint}) + (20 \text{ mA} * \text{StartPoint}) - (4 \text{ mA} * \text{EndPoint})}{16 \text{ mA}}$$

$$\text{Measuring value in mm} = \frac{\text{Measuring value in V} * (\text{EndPoint} - \text{StartPoint}) + (10 \text{ V} * \text{StartPoint})}{10 \text{ V}}$$

For the measurement modes X-Center, Z-Center, Z-Top, X-Left, X-Right, this conversion of the analog signal will also apply. That is, e.g. will set the minimum and maximum evaluated X-center position as the StartPoint and EndPoint in SCALE OUT and above formulas for the conversion of the signal on X-Center is used in mm.

**6.7.2 Sync-In / Trigger**

The measurement and signal output can be interrupted with the Sync-In input by connecting with high. As long as Sync-In stands at high, the sensor delays the next measurement (Hold) and reduces the power of the laser beam.

- The sensor checks the Sync-in before each measurement
- The previous measurement cycle will be always completed, even if the sync-in is High
- The sensor reduces the power of the laser beam during the waiting period (Hold)
- The outputs are held in the last valid state during Hold
- To come back to measuring mode, the Sync-In has to be set from High to Low
- The Sync-in must be at least 5µs at Low to come back to the measuring mode

Sync-In	Level	Measurement
Sync-In low	0...2.5 V	Run
Sync-In high	8 V...UB (operating voltage)	Hold

**Example: Mutual interference**

Only the laser beam of Sensor1 may be in the measuring field of Sensor1. The laser beam of Sensor2 must be outside the measuring field from Sensor1.

If it is not possible to prevent several sensors from affecting each other through appropriate installation, the sensors affecting each other can be operated asynchronously by the Sync-In cable. The superordinate control generates the signals for this.



**HINT**

Once the Sync-In is set to High (Hold), all output functions are frozen in their last state until the next measurement.

**Measuring if Sync-In low**

The sensor checks the level of the Sync-In each time before it sends out the laser pulse. If it is low, the sensor will immediately begin the next measurement.

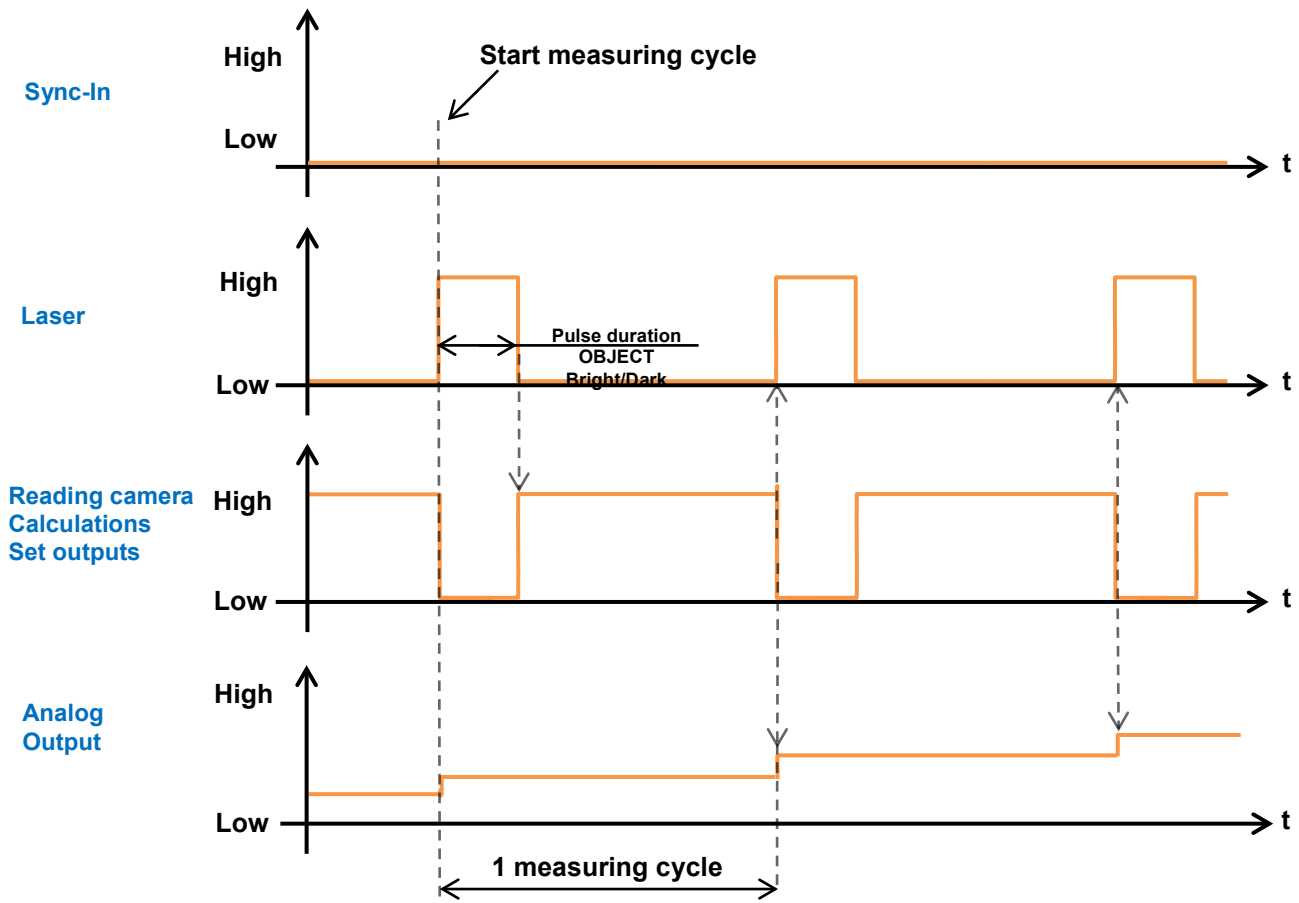

**Sync-In Low to High:**

If the Sync-In level is High, the sensor completes the actual measurement, but do not start the next measurement. All outputs are held (Hold function).

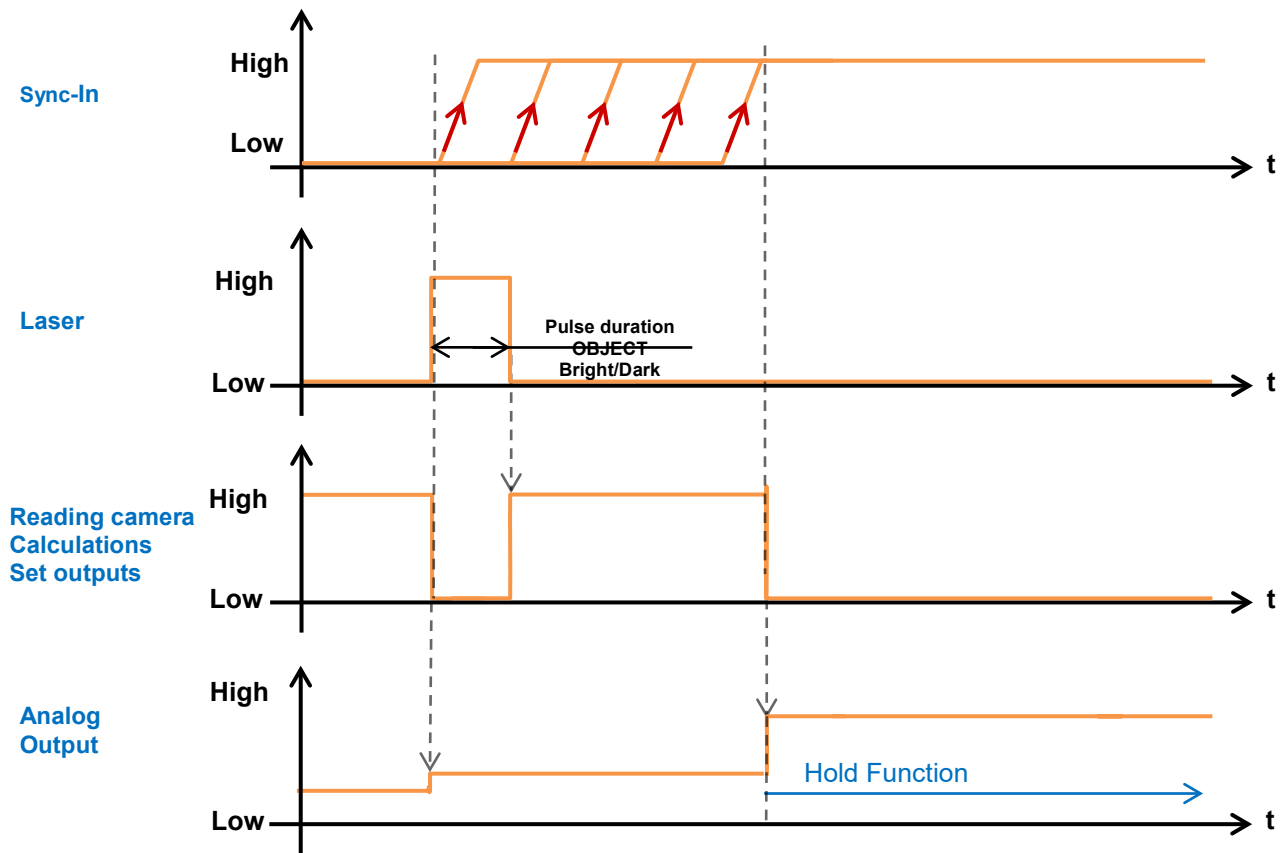

**Hold-Eingang von High auf Low:**

Sync-In has to set from High to Low to bring the sensor back into the measuring mode. The Sync-In must be at least 5µs set to low level, so that the sensor starts to measure. For this first measuring cycle, the response time will be 5µs longer.

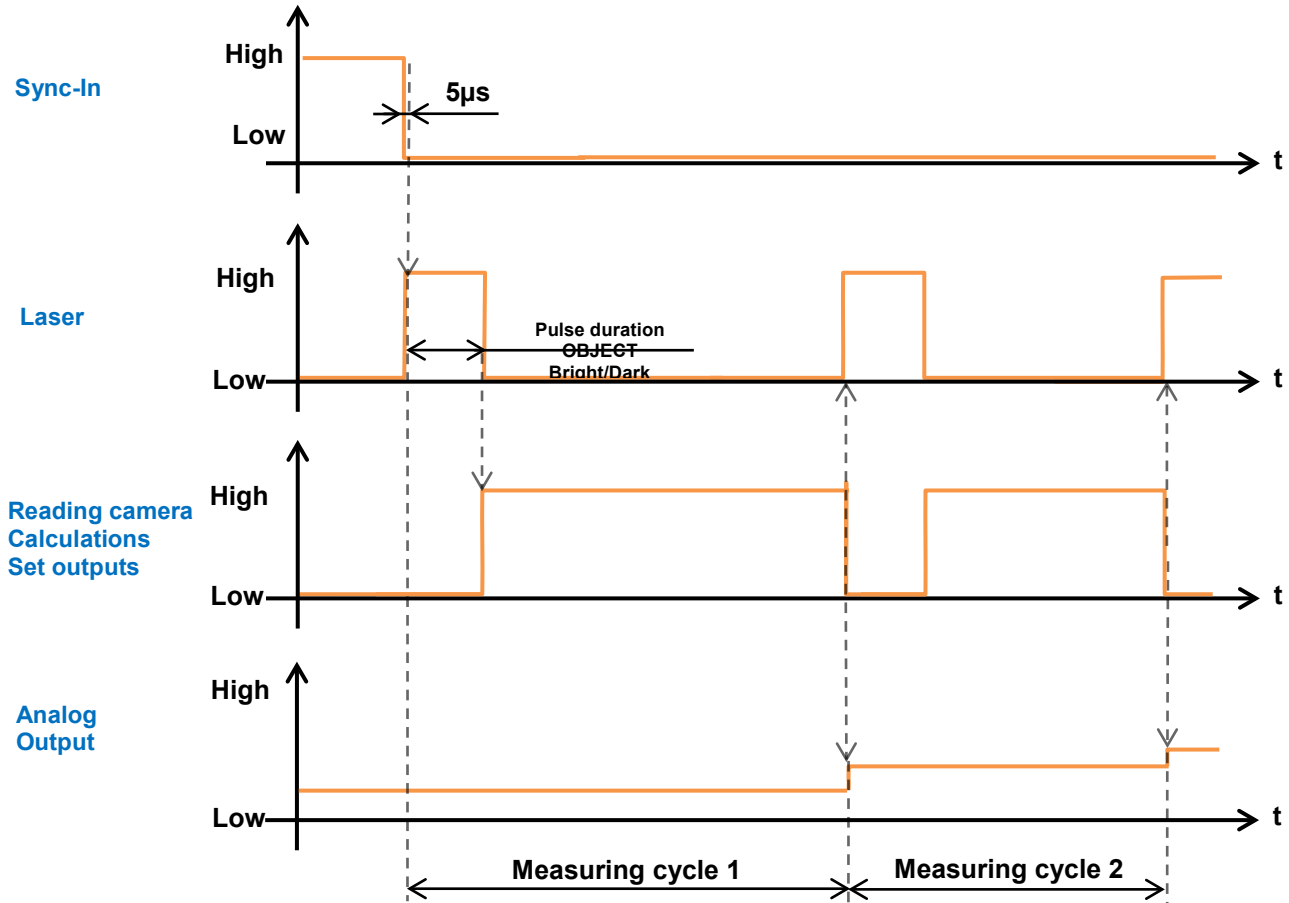

**6.7.3 Switching output**

The switching output can be set as a point or a window, see Section DIGITAL OUT.

The output is transmitted as a push-pool signal with active high or active low (inverted), depending on the setting.

**6.7.4 Alarm output**

The sensor evaluates the signal level (amount of reflected light) during every measurement cycle. If this level falls below a defined value (signal gain), the alarm output and red LED on the sensor are activated.

Reasons for a low signal level:

- Signal gain too small
- Incorrect mounting angle
- Insufficient light reflected from the object
- Object outside the measuring field

Signal level	Red LED	Alarm output out2
Signal gain reached	Off	Low
Signal gain not reached	Blinks (8 Hz)	Low
No object inside the measuring range	On	High

The alarm output cannot be adjusted and is triggered by the following situations:

- No object in the measuring field
- Insufficient signal gain (e.g. with soiling) or or incorrect OBJECT setting.

The alarm signal is output as a push-pull signal (active high).

**NOTE**



There is no excess gain hysteresis, which is why rapid switching between alarms can occur.

## 6.8 Touch panel

### 6.8.1 Function and design

The display consists of a monochrome 128 x 32 pixel LCD with RGB LED background illumination. The sensor can be configured using four capacitive touch operator interfaces.

### 6.8.2 Dimensioning

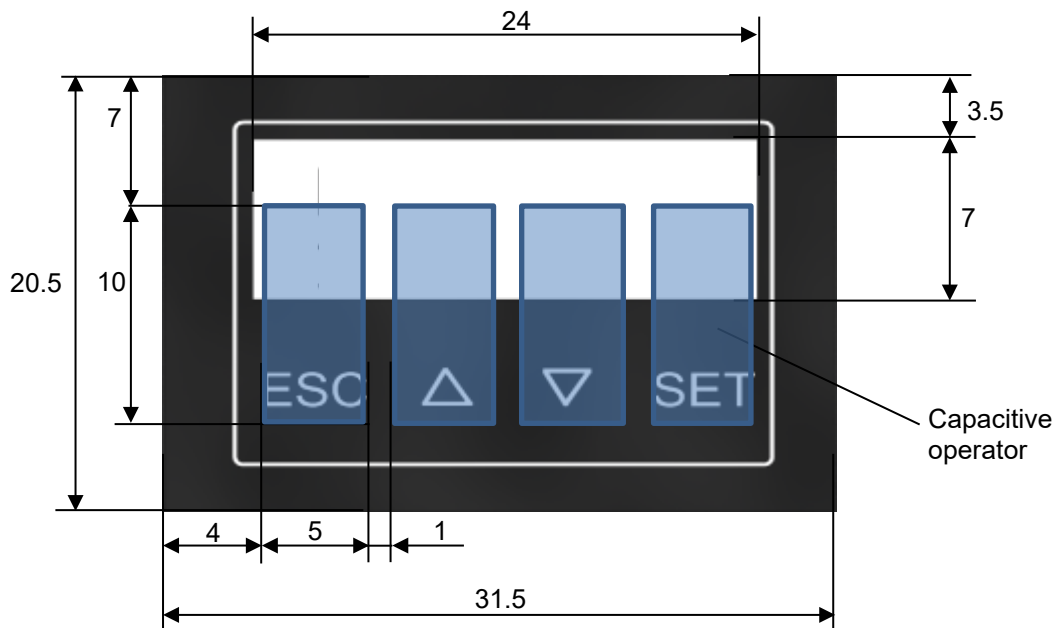

## 6.9 Memory

All changes made in the sensor are saved in nonvolatile (permanent) memory and are even retained after a power outage.

## 7 Safety instructions and maintenance

### 7.1 General safety instructions

#### Intended use

This product is a precision device and is used for object detection and the preparation and/or provision of measuring values as electrical quantities for a subsequent system. Unless this product is specially labeled, it may not be used for operation in potentially explosive environments.

#### Commissioning

Installation, mounting and adjustment of this product may be performed only by a qualified person.

#### Installation

For mounting, use only the mechanical mountings and mechanical mounting accessories intended for this product. Unused outputs must not be wired. In cable versions with unused cores, these cores must be insulated. Always comply with admissible cable bending radii. Prior to electrical connection of the product, the system must be disconnected from the power supply. In areas where shielded cables are mandatory, they must be used as protection against electromagnetic disturbances. If the customer makes plug connections to shielded cables, an EMC version of the connectors should be used, and the shield must be connected to the connector housing across a large area.

#### CAUTION

Use of controls or adjustments or performance of procedures other than those specified herein may result in hazardous light exposure.

### 7.2 Part identification

<p style="writing-mode: vertical-rl; transform: rotate(180deg);"><b>Explanatory and warning label</b></p>	<p style="text-align: center;"><b>Class 1: No risk to eyes or skin</b></p> <div style="border: 2px solid black; padding: 10px; text-align: center; margin: 10px auto; width: 80%;"> <p><b>CLASS 1 LASER PRODUCT</b></p> </div> <p>A Class 1 laser product is defined as safe in normal operations under reasonably foreseeable conditions, including long-term direct viewing of the beam, even when exposure occurs while using telescopic optics. However, direct viewing of a Class 1 laser product may still produce dazzling visual effects, particularly in low ambient light.</p>	<p style="text-align: center;"><b>Class 2: Do not stare into beam</b></p> <div style="display: flex; align-items: center; justify-content: center; margin: 10px auto;">  <div style="border: 2px solid black; padding: 5px; text-align: center; width: 150px;"> <p><b>LASER RADIATION DO NOT STARE INTO BEAM</b> Wavelength: 640...670nm  IEC 60825-1, Ed. 3, 2014 <b>CLASS 2 LASER PRODUCT</b></p> </div> </div> <p>Class 2 lasers emit radiation in the visible portion of the spectrum (400 nm to 700 nm). A short-term exposure (duration to 0.25 s) is harmless to the eye. Random short-term impacts (to 0.25 s) do not damage the eye, because the blink reflex can automatically adequately protect the eye against longer irradiation. Class 2 lasers may be used without any additional protection, if it is ensured that for an application no intentional look longer than 0.25 s is required, or (for example, by drug exposure) the blink reflex is suppressed.</p>
<p style="writing-mode: vertical-rl; transform: rotate(180deg);"><b>Certification label</b></p>	<p>FDA certification label</p>	
<p style="writing-mode: vertical-rl; transform: rotate(180deg);"><b>Identification label</b></p>	<p>The sensor identification part contains the following information:</p> <ul style="list-style-type: none"> <li>• Company Logo</li> <li>• Sensor brand name</li> <li>• Article description and article number</li> <li>• Production information</li> <li>• Serial number</li> </ul>	

### 7.3 Influence of ambient light

Ambient light from lamps, the sun, etc. in the view field of the sensor can lead to malfunctions or a reduction of accuracy and should be avoided as much as possible.

### 7.4 Front (optics)

In the event of broken front window, broken display panel or loose or detached laser optics the sensor must immediately be disconnected from the power supply and it must not be put back into operation until it has been repaired by an authorized person.

Non-compliance with these safety instructions may result in hazardous radiation exposure!



**ATTENTION!**

The use of a sensor with a broken front glass or dissolved or detached lens may result in hazardous radiation exposure.

## 7.5 Cleaning the sensors

The laser distance sensors do not require any maintenance, except that the front windows must be kept clean. Dust and fingerprints can impair sensor function. It is normally sufficient to wipe the windows with a clean (!), soft lens cleaning cloth. Alcohol or soapy water can be used in case of severe soiling. The display and the keys must be kept free from dirt and moisture. Water and dirt on the keys can impair their function.

## 7.6 Disposal

This sensor contains electronic components. Components are to be disposed of according to the regulations prevailing in the respective country.

## 8 Troubleshooting and tips

### 8.1.1 Definition

The Error indicator is a relative value in percentage. A prerequisite for the correct calculation is that the sensor is perpendicular to the object.

The lower the error indicator, the safer the measured value is (0 means very high security). If the value of the Error indicator is larger than 0.2, then the measured value is discarded and no measurement output (sensor status as "No object in the measuring field"). Optionally, should then be checked the measurement conditions.

### 8.1.2 Factors

The following may affect the Error indicator:

#### Statistical noise

Statistical noise is influenced by different material, lighting, measuring distance, e.g. The Error indicator rises by the same amount of random noise.

#### Number of measurement points

The more measurement points include the curve of the circle, the better the circle can be calculated and the smaller the error indicator value will be.

#### Radius

The larger the object radius, the less (better) is the value of the Error indicator.

#### Central angle of the circle sector

The central angle is the angle, which indicates the amounts measured segment area from the object. A larger center angle improves the accuracy of the measured value and reduces the error indicator value. At least 120 ° of a circle must be able to be detected.

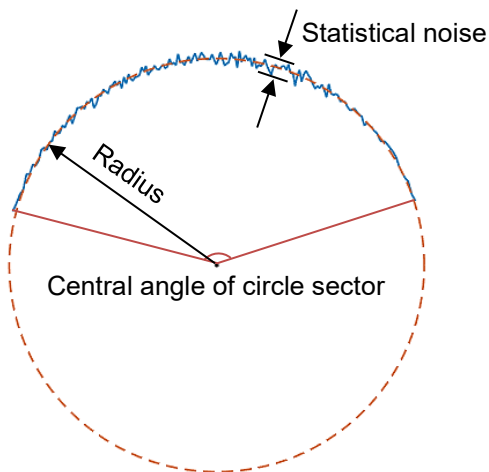

## 8.2 Error correction

Fehler	Fehlerbehebung
No function	<ul style="list-style-type: none"> <li>• Check connection. Power supply 15...28 VDC between pin 2 (+Vs, brown) and pin 7 (GND, blue)</li> </ul>
Green LED flashes	<ul style="list-style-type: none"> <li>• Short circuit at the digital output. Check connection.</li> </ul>
Red LED lights up	<ul style="list-style-type: none"> <li>• Object outside measuring field (near, far or to the side)</li> <li>• Amplitude of the received signal is insufficient (e.g. in case of soiling)</li> </ul>
Touch panel cannot be operated	<ul style="list-style-type: none"> <li>• Touch panel locked. Re-enable panel for operation by sliding a finger over the 4 keys from left to right.</li> </ul>
Touch panel does not react	<ul style="list-style-type: none"> <li>• Clean panel. The panel is dirty or wet, which makes it harder to press the keys</li> </ul>
Sensor does not provide the expected measuring results	<ul style="list-style-type: none"> <li>• The object is not sufficient in the measuring range</li> <li>• The measurable central angle is too low and requires a centering of the object in the measuring range</li> <li>• Remove more unwanted objects in the measuring range or limitation of the field of view</li> <li>• Check inclination angle and work with the FLEX MOUNT mode if required (teach in the new reference surface)</li> <li>• Bright object, avoid direct reflexes from the transmitter to the receiver</li> </ul>
The sensor does not capture the object within the measuring field	<ul style="list-style-type: none"> <li>• Enlarge measuring field. The measuring field was possibly limited; see " FIELD OF VIEW " Section</li> <li>• The red visible laser beam does not represent the maximum measuring field. If the object is at the edge of this beam it could be outside the measuring range</li> <li>• Move object. The object is outside the measuring field vertically or is in the blind region of the sensor</li> </ul>
Unreliable measuring value: The measuring value jumps back and forth	<ul style="list-style-type: none"> <li>• The object is not in the measuring range</li> <li>• Avoid bright object</li> <li>• Avoid very dark object</li> <li>• Enable in function OBJECT: "dark" for objects with a dark color</li> <li>• Too much ambient light</li> <li>• Check measuring mode setting (MEAS TYPE)</li> <li>• Further unwanted object in the measurement range</li> <li>• Object is not circular</li> </ul>
Transmitting laser light is dim	Sync-In input is on High--> set to Low