

Original operating Instructions for the safety relay for safety light curtains

AO000299



Table of contents

Important Notes	Page 2
Safety Regulations	Page 2
Designated Use	Page 3
Main Features	Page 3
Practical Notes	Page 3
Safety Notes	Page 4
Connection Terminals	Page 4
Function Diagram	Page 5
Block Diagram	Page 5
Indicators	Page 5
Setting	Page 5
Technical Data (input circuit / output)	Page 6
Technical Data (General Data)	Page 7
Safety related data	Page 7
Characteristics	Page 8
Dimensions	Page 8
Application examples	Page 9
Troubleshooting	Page 10
Maintenance and repairs	Page 10
Labeling and connections	Page 11
EC Declaration of Conformity	Page 12

Before installing, operating or maintaining this device, these instructions must be carefully read and understood.



Danger!



Dangerous voltage! Electric shock will result in death or serious injury. Disconnect all power supplies before servicing equipment.



Caution!

Safe operation of the device is only guaranteed when using certified components.

Important Notes

The product hereby described was developed to perform safety functions as a part of a whole installation or machine. A complete safety system normally includes sensors, evaluation units, signals and logical modules for safe disconnections. The manufacturer of the installation or machine is responsible for ensuring proper functioning of the whole system. ipf cannot guarantee all the specifications of an installation or machine that was not designed by ipf. The total concept of the control system into which the device is integrated must be validated by the user. ipf also takes over no liability for recommendations which are given or implied in the following description. The following description implies no modification of the general ipf terms of delivery, warranty or liability claims.



Safety Regulations

- This device must be installed and operated by staff who are familiar with these instructions and with the current regulations for safety at work and accident prevention.
- Pay attention to applicable local regulations, especially regarding safety measures.
- The shock protection on the connected elements and the cable insulation must be designed for the highest voltage applied to the device .
- Opening the device or implementing unauthorized changes voids any warranty.
- The unit should be panel mounted in an enclosure rated at IP 54 or superior. Dust and dampness may lead to malfunction.
- Adequate fuse protection must be provided on all output contacts with capacitive and inductive loads.
- The safety function must be triggered at least once a month.

Designated use

The AO000299 is used for safe interruption of a safety circuit. It can be used to protect people and machines in applications with light curtains.

When used in accordance with its intended purpose and following these operating instructions, this device presents no known residual risks. Nonobservance may lead to personal injuries and damages to property.

Main features

- According to:
 - Performance Level (PL) e and Category 4 to EN ISO 13849-1:2008
 - SIL Claimed Level (SIL CL) 3 to IEC/EN 62061
 - Safety Integrity Level (SIL) 3 to IEC/EN 61508
 - Category 4 to EN 954-1
- For light curtains with symmetric or asymmetric outputs, adjustment with switch S1
- Output: 3 x no, 1 x nc (the nc-contact can only be used for monitoring)
- Single and 2-channel operation
- Line fault detection on On-button (monitored start)
- Manual restart or automatic restart, switch S2
- LED indicator for channel 1 and 2 and power
- LED-Anzeigen für Kanal 1, 2 und Netz
- Fixed screw terminals

Practical Notes

Line fault detection on On-button:

The line fault detection is only active when S12 and S22 are switched simultaneously. If the ON-button is closed before S12, S22 is connected to voltage (also when line fault across On-button), the output contacts will not close. A line fault across the On-button which occurred after activation of the relay, will be detected with the next activation and the output contacts will not close

To operate light curtains with symmetric outputs (both channels switching +) the selector switch S1 has to be in position "without". To operate light curtains with asymmetric outputs (1 channel switches +, one channel -) the selector switch S1 has to be in position "with" The channel switching - must be connected to S22, channel switching + to S12.



Safety Notes

ATTENTION! If a line fault occurs after the voltage has been connected to S12, S22, the unit will be activated because this line fault is similar to the normal On-function.

ATTENTION! Switch S1 must not be set while device is under supply voltage.

Switch S2 is used to select automatic or manual restart. Additionally, for the function "automatic restart", terminals S33 and S34 have to be bridged. Connect the device according to application examples. .

The ipf safety light curtains have a switching function between automatic and manual start. If the function "manual start" is used at the safety light curtain, the function "automatic restart" has to be chosen on the relay AO000299.

Connection Terminals

Terminal designation	Signal designation
A1 +	Supply Voltage +
A2 -	Supply Voltage -
S12, S22, S33, S34	Control Inputs
S11, S21	Control Outputs
13, 14, 23, 24, 33, 34	Forcibly guided NO contacts for release circuit
41, 42	Forcibly guided NC contact (indicator output)

Function Diagram

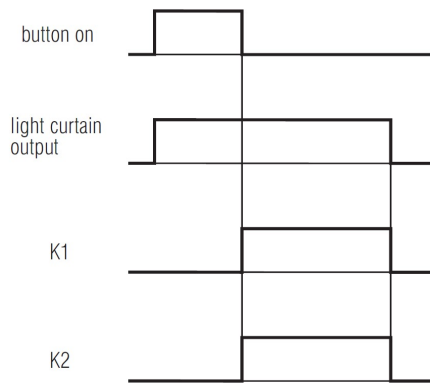

Block Diagram

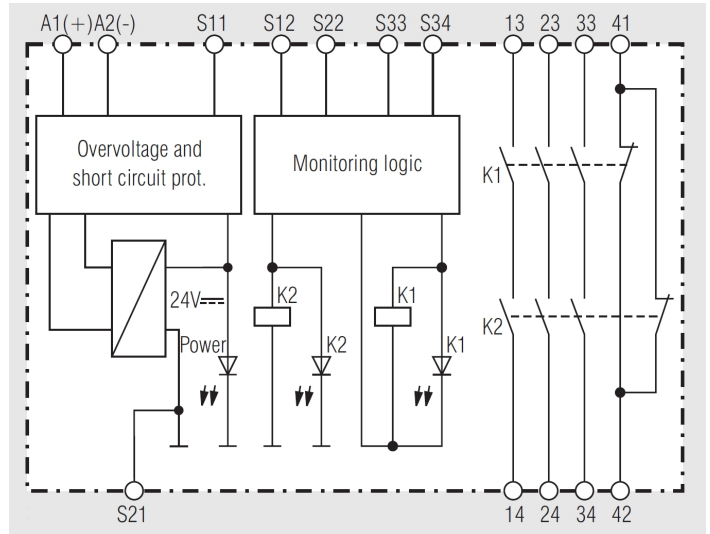

Indicators

- LED Power: on when supply connected
- LED K1/K2: on when relay K1 and K2 energized

Setting

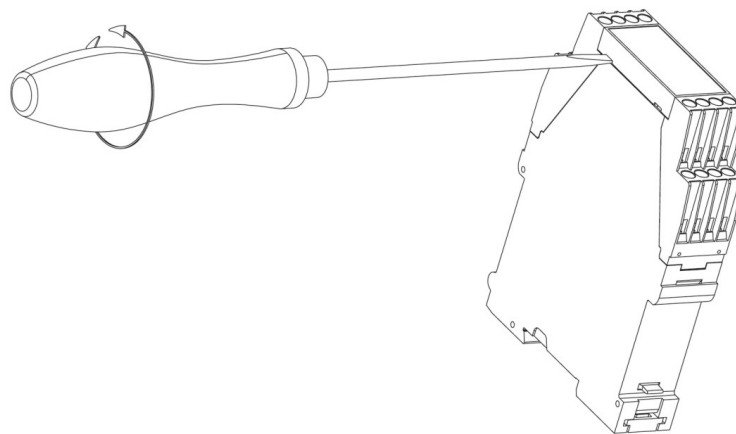
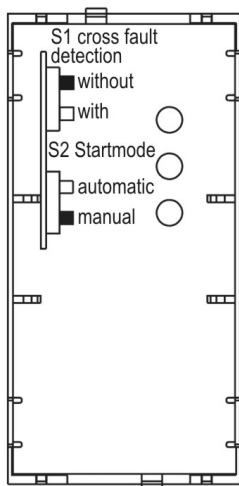

To set the switches S1 and S2 please remove the cover of the AO000299 in assistance of a screwdriver etc. (see illustration).

The Drawing shows setting at the state of delivery.

Disconnect the unit before setting of S1!

Technical Data

Input Circuit

Nominal Voltage U_N	24V DC
Voltage Range	0,90 ... 1,1 U_N
Nominal consumption	approx. 1,7W
Min. Off-time	250ms
Control voltage on S11 at U_N	22,5V DC
Control current over S12, S22	typ. 35mA at U_N
Min. voltage on S12, S22 When relay activated	21V DC
Short circuit protection	internal PTC
Overvoltage protection	internal VDR

Output

Contacts	3 NO-, 1 NC- (The NC contacts 41-42 can only be used for monitoring)		
Operate delay (typ.) at U_N			
Manual start	20ms		
Automatic start	350ms		
Release delay (typ.) at U_N			
Disconnecting the supply:	20ms		
Disconnecting S12, S22	15ms		
Nominal output voltage	max. 250V AC DC: see limit curve for arc-free operation		
Switching of low loads (contact 5 μ m Au)	≥ 100 mV ≥ 1 mA		
Thermal Current I_{th} :	max. 8A per contact (see current limit curve)		
Switching capacity			
to AC 15	NO-contacts	3A / 230V AC	IEC/EN 60 947-5-1
	NC-contacts	2A / 230V AC	IEC/EN 60 947-5-1
to DC 13	NO-contacts	2A / 24V DC	IEC/EN 60 947-5-1
	NC-contacts	2A / 24V DC	IEC/EN 60 947-5-1
Electrical contact life to 5A, 230V AC, $\cos\phi = 1$	$> 2,2 \times 10^5$ switching cycles		
Permissible operating frequency	max. 1200 operating cycles / h		
Short circuit strength			
max. fuse rating	10A gL	IEC/EN 60 947-5-1	
line circuit breaker	B 6A		
Mechanical Contact Life	$> 20 \times 10^6$ switching cycles		

General Data

Operating mode	Continuous operation	
Temperature range		
operation	-15 ... +55°C	
storage	-25 ... +85°C	
Altitude	< 2000m	
Clearance and creepage distances		
Rated impulse Voltage	4kV	
Pollution Degrie	2 (Basis insulation)	IEC 60 664-1
EMC		
Electrostatic discharge (ESD)	8kV (air)	IEC/EN 61 000-4-2
HF irradiation	10V/m	IEC/EN 61 000-4-3
Fast Transients	2kV	IEC/EN 61 000-4-4
Surge Voltages		
between wires for power supply	0,5kV	IEC/EN 61 000-4-5
between wire and ground	2kV	IEC/EN 61 000-4-5
Interference suppression	Limit value class B	EN 55 011
Degree of Protection		
Housing	IP40	
Terminals	IP20	
Housing Material	Thermoplastic with V0-behaviour according to UL Subject 94	
Vibration resistance	Amplitude 0,35mm, frequency 10 ... 55Hz	IEC/EN 60068-2-6
Climate resistance	15 / 055 / 04	IEC/EN 60068-1
Terminal designation	EN 50 005	
Wire connection	DIN 46228-1/-2/-3/-4	
Wire fixing	Plus-Minus terminal screwsM3,5 Box terminals with wire protection	
Mounting	DIN rail	IEC/EN 60 715
Weight	220g	

Safety related Data
EN ISO 13849-1

Category	4
PL	e
MTTF _d	584,5a (year)
DC _{avg}	99,0%
d _{op}	220d/a (days/year)
h _{op}	12h/d (hours/day)
t _{cycle}	3600s/cycle (= 1/h)

**IEC/EN 62061
IEC/EN 61508**

SIL CL	3 (IEC/EN 62061)
SIL	3 (IEC/EN 61508)
HFT	1
DC _{avg}	99%
SFF	99,7%
PFH _D	2,66 x 10 ⁻¹⁰ h ⁻¹
T ₁	20a (year)

Characteristics

Arc limit curve under resistive load

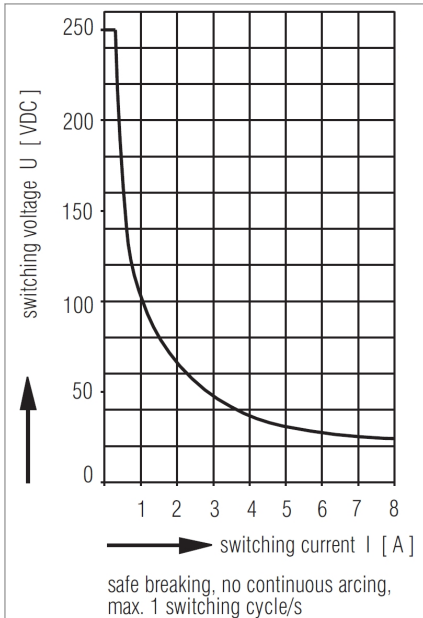

Total current limit curve

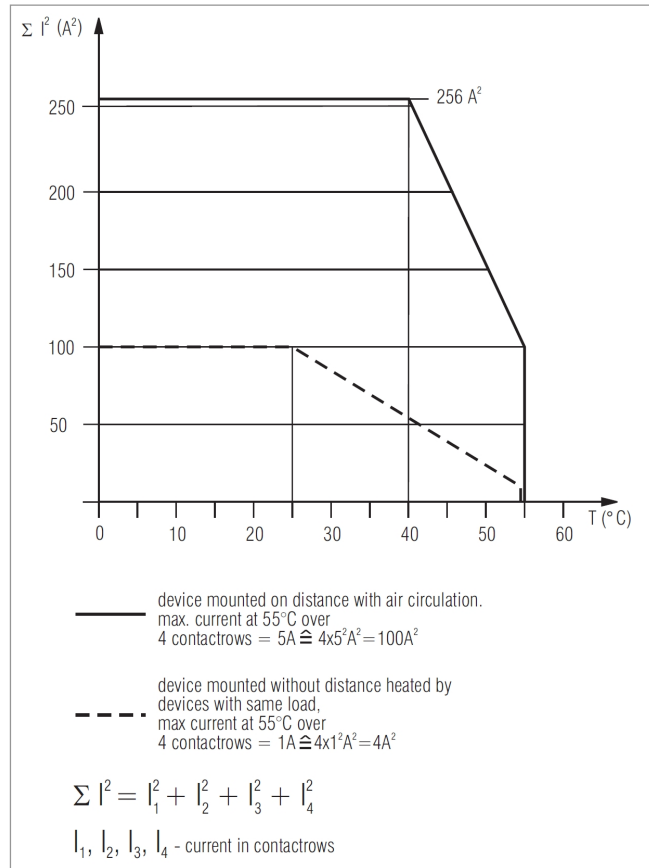

Dimensions (in mm)

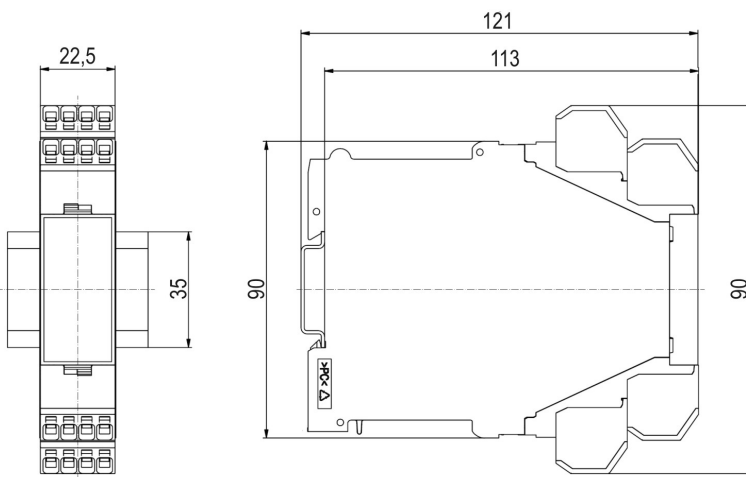

Application examples

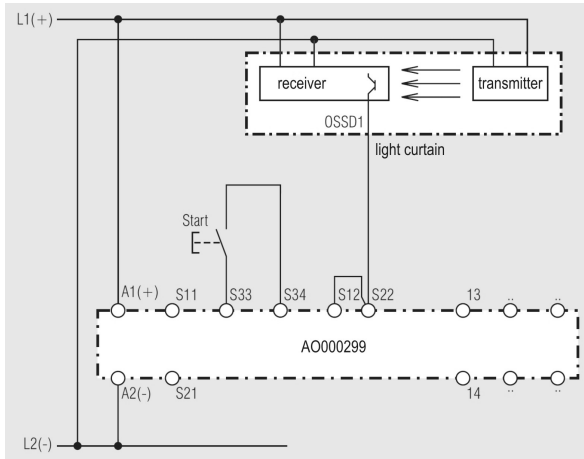

Single channel connection of light curtains with self-test according to EN 61 496-1.

Note: Refer to "Setting"!

Switches in Position:

S1: "without"

S2: "manual"

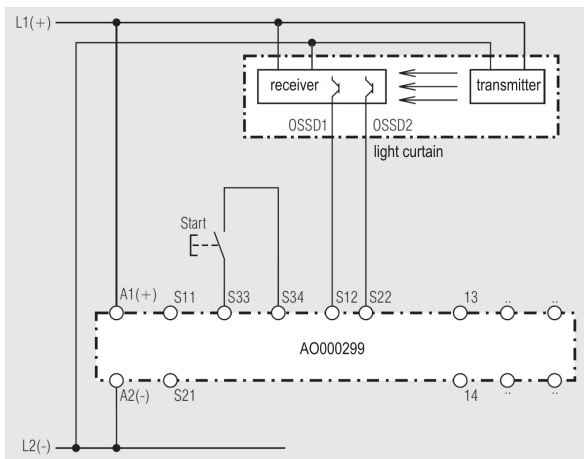

2 channel connection of light curtains with self-test according to EN 61 496-1.

Cross fault detection in the light curtain.

Note: Refer to "Setting"!

Switches in Positions:

S1: With symmetric outputs on light curtains switch S1 in position "without".

With asymmetric outputs on light curtains switch S1 in position "with".

S2: "manual"

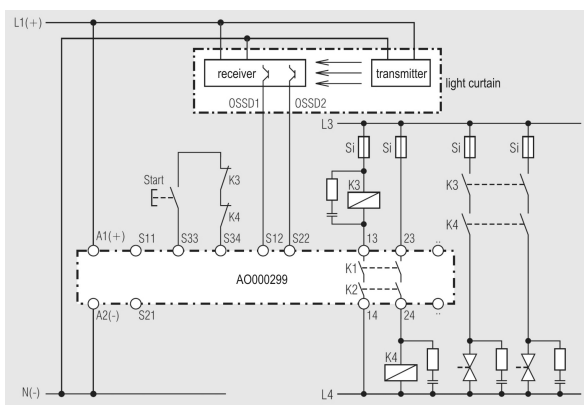

Contact reinforcement and contact extension by external contactors.

Note: Refer to "Setting"!

Switches in Positions:

S1: With symmetric outputs on light curtains switch S1 in position "without".

With asymmetric outputs on light curtains switch S1 in position "with".

S2: "manual" S1:

Troubleshooting

Failure:	Potential Course:	Action:
LED „Power“ does not light up	- Power supply not connected	- Switch on the power supply!
LED „K1“ lights up, but „K2“ remains off	- Safety relay K1 is welded - A 1-channel switch-off occurred on S12	- Replace the device! - Switch channel off on S22!
LED „K2“ lights up, but „K1“ remains off	- Safety relay K2 is welded - A 1-channel switch-off occurred on S22	- Replace the device! - Switch channel off on S12!
Device cannot be activated	Manual Start Mode: - Line fault on start-button Automatic Start Mode: - S33-S34 not bridged - A safety relay is welded - Incorrect setting of switch S1	- Disconnect power supply and remove fault! - Connect S33 with S34! - Replace the device! - Control switch S1 und bring it in the correct position!

Maintenance and repairs

- The device contains no parts that require maintenance
- In case of failure, do not open the device but send it to the manufacturer for repair.

Labeling and connections

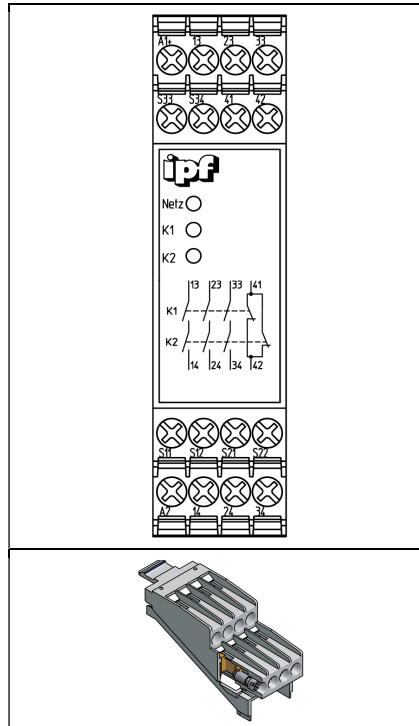

	<p>ø 4 mm / PZ 1 0,8 Nm 7 LB. IN</p>
	<p>A = 8mm 1 x 0,5 ... 4 mm² 1 x AWG 20 to 12 2 x 0,5 ... 2,5 mm² 2 x AWG 20 to 14</p>
	<p>A = 8mm 1 x 0,5 ... 2,5 mm² 1 x AWG 20 to 14 2 x 0,5 ... 1,5mm² 2 x AWG 20 to 16</p>
	<p>A = 8mm 1 x 0,5 ... 4mm² 1 x AWG 20 to 12 2 x 0,5 ... 2,5mm² 2 x AWG 20 to 14</p>

EC-Declaration of Conformity

The

ipf electronic gmbh
Kalver Str. 27
D – 58515 Lüdenscheid

declares hereby that the following product:

product description: safety switching device for electro-sensitive protective devices
type designation: **AO000299**

conforms to the following European Standards:

EMC-Directive:	2004/108/EG
Machinery directive:	2006/42/EG
Basis of testing:	EN ISO 13849-1:2008 + AC :2009
	EN 62061 :2005
	EN 60947-5-1:2004 + A1 :2009
	EN 60204-1:2006 + A1 :2009 (in extracts)
	EN ISO 13850 :2008
	EN 50178 :1997

The product has been validated by the following testing institutes:

TÜV Rheinland Industrie Service GmbH
Alboinstraße 56
D - 12103 Berlin

Name of the documentation representative: Jörg Hesse
Adress of the documentation representative: see adress of the manufacturer

Lüdenscheid, 01.02.2013

signature J. Hesse
quality management representative

This declaration confirms the conformity of the mentioned directives but does not comprise any guarantee of the product characteristics.
The safety directives of the product documentation are to be considered.

EC Type-Examination Certificate



Product Safety
Functional
Safety

www.tuv.com
ID 0600000000

Reg.-Nr./No.: 01/205/5153.01/15

Prüfgegenstand Product tested	Nachschalgerät für berührungslos wirkende Schutzeinrichtungen Safety relay unit for safety light curtains	Zertifikatsinhaber Certificate holder	ipf electronic gmbh Kalver Str. 27 58515 Lüdenscheid Germany
Typbezeichnung Type designation	AO000299		
Prüfgrundlagen Codes and standards	EN ISO 13849-1:2008 + AC:2009 EN 62061:2005 + AC:2010 + A1:2013 EN ISO 13850:2008	EN 60947-5-1:2004 + AC:2005 + A1:2009 EN 60204-1:2006 + A1:2009 + AC:2010 (in extracts) EN 50178:1997	

Bestimmungsgemäße Verwendung
Intended application

Das Gerät erfüllt die Anforderungen der Prüfgrundlagen (Kat. 4 / PL e nach EN ISO 13849-1, SIL CL 3 nach EN 62061) und kann in Anwendungen bis PL e und SIL 3 eingesetzt werden.
The device complies with the requirements of the relevant standards (Cat. 4 / PL e acc. to EN ISO 13849-1, SIL CL 3 acc. to EN 62061) and can be used in applications up to PL e and SIL 3.

Besondere Bedingungen
Specific requirements

Die Hinweise in der zugehörigen Installations- und Betriebsanleitung sind zu beachten.
The instructions of the associated Installation and Operating Manual shall be considered.

Es wird bestätigt, dass der Prüfgegenstand mit den Anforderungen nach Anhang I der Richtlinie 2006/42/EG über Maschinen übereinstimmt.

It is confirmed, that the product under test complies with the requirements for machines defined in Annex I of the EC Directive 2006/42/EC.

Gültig bis / Valid until 2020-11-02

Der Ausstellung dieses Zertifikates liegt eine Prüfung zugrunde, deren Ergebnisse im Bericht Nr. 968/EZ 518.01/15 vom 02.11.2015 dokumentiert sind.

Dieses Zertifikat ist nur gültig für Erzeugnisse, die mit dem Prüfgegenstand übereinstimmen. Es wird ungültig bei jeglicher Änderung der Prüfgrundlagen für den angegebenen Verwendungszweck.

The issue of this certificate is based upon an examination, whose results are documented in Report No. 968/EZ 518.01/15 dated 2015-11-02.

This certificate is valid only for products which are identical with the product tested. It becomes invalid at any change of the codes and standards forming the basis of testing for the intended application.

Berlin, 2015-11-02

Notified Body for Machinery, NB 0035

Dipl.-Ing. Eberhard Frejno

www.fs-products.com
www.tuv.com

 **TÜVRheinland**[®]
Genau. Richtig.