

**AY000166**

**ACCESSORIES • MOUNTING**

accessories sensor, Two-way clamp holder, 16x48x16mm, Aluminum

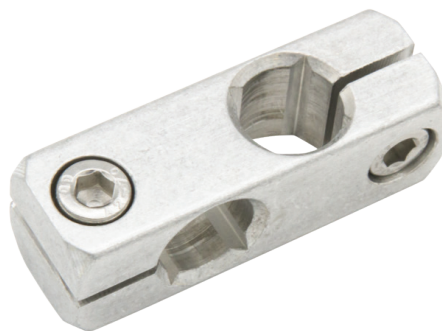

**MECHANICAL FEATURES**

Height	16 mm
Housing material	Aluminum
Length	48 mm
Material	Aluminum
Type of mechanical accessories	Two-way clamp holder
Width	16 mm

**ELECTRICAL FEATURES**

Internal hole diameter	12 mm
------------------------	-------

**OTHER FEATURES**

Current plunger	-
-----------------	---

**Other**

Packaging dimensions	100mm x 16.0mm x 120mm
Shipping weight	0.02kg
Tariff code	76169990

**Classification**

ipf product group	900
eClass 8.0	27279202
eClass 9.0	27273701
eClass 9.1	27273701
ETIM-5.0	EC002024
ETIM-6.0	EC002024
ETIM-7.0	EC002024

**Connection**

## Dimensional drawing

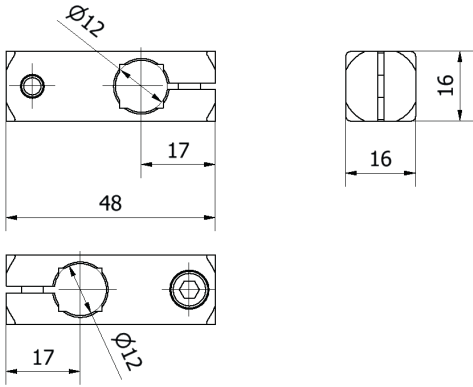

## Installation



Mounting / installation may only be carried out by a qualified electrician!

## Disposal



## Safety warnings

Before initial operation, please make sure to follow all safety instructions that may be provided in the product information. Never use these devices in applications where the safety of a person depends on their functionality. LED lighting systems can generate intensive UV radiation, which can damage your eyes in case of improper use. The manufacturer cannot be held responsible for damages that result from improper use or connection.