

dimensions	<b>15.4 x 50 x 50mm</b>	
retro-reflective sensors	range	<b>up to 11m</b>
dif. reflection sensor	sensing range	<b>up to 300mm</b>

- ✓ background and foreground suppression for the diffuse reflection devices
- ✓ retro-reflective sensors with polarizing filter and setting control
- ✓ high range of the retro-reflective sensors
- ✓ recognition of the smallest of objects
- ✓ light-on and dark-on mode
- ✓ fast response time
- ✓ LED-display of the switch signal
- ✓ simple adjustment
- ✓ robust metal housing
- ✓ laser class 1 or 2

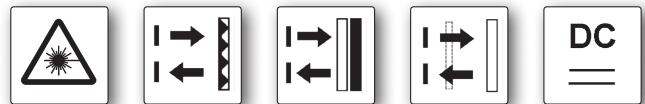

**visible laser with glass lens  
high precision positioning**



**description**

These days, optoelectronic sensors are indispensable components in many automated manufacturing processes. Highly accurate laser sensors are used everywhere where parts have to be contactlessly detected, counted, measured or positioned - in a very reliable and fast way. They help to accurately detect the position of objects made from metal, glass, plastic, wood, paper and much more.

The sensors of this series feature glass lenses in a robust zinc diecast housing.

They can always be aligned easily and reliably using the small, red laser spot.

The distance setting of the diffuse reflection devices takes place via a mechanical setting unit. Degree of protection IP67 is retained and objects are recognized reliably, regardless of their color. The functional principle behind these diffuse reflection sensors is based on the triangulation principle, in which the position of the object is determined by the angle of light reflected from it. It must be ensured with all triangulation

sensors that the laser spot can be directly seen by the receiver lens and that there are no obstacles in front of the lens.

The yellow LED display lights up if the output is securely switched. If the yellow LED of the retro-reflective sensor flashes when the output is switched, the devices are working without sufficient functional reserve. This is the case for example, if the sensors are soiled or misadjusted.

For avoiding mutual optical interference the diffuse reflection devices have a built-in interference suppression. As a result, it is possible to mount sensor upon sensor without causing erroneous operations.

**application examples**

- ▶ detection of object edges with high precision
- ▶ check of parts of any form and color
- ▶ contactless position recognition
- ▶ pulse generator for counting devices
- ▶ recognition of the smallest of objects



article-no.	PR170400	PR170420
version	retro-reflective sensor polarizing filter	retro-reflective sensor polarizing filter
range	up to 11m	up to 11m
connection	cable	connector

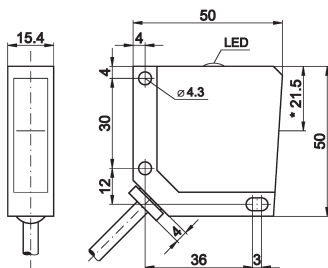

\* transmitter axis: 21.5mm

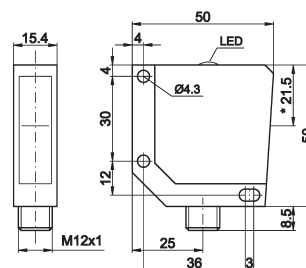

\* transmitter axis: 21.5mm

TECHNICAL DATA		
range	up to 11m	up to 11m
output signal	pnp, light-on/dark-on mode	pnp, light-on/dark-on mode
operating voltage	10 ... 30V DC	10 ... 30V DC
current consumption (w/o load)	≤ 70mA	≤ 70mA
output current (max. load)	200mA	200mA
voltage drop (max. load)	2.0V DC	2.0V DC
transmitting element (pulsed)	laser diode, red light	laser diode, red light
wavelength	650nm	650nm
laser focus distance	400mm	400mm
laser class	1	1
response/decay time	< 0.1ms	< 0.1ms
switching frequency	5kHz	5kHz
display (signal/reserve)	yellow LED / flashing	yellow LED / flashing
sensitivity adjustment	-	-
interference suppression	-	-
repeat accuracy	< 1.5mm (at 0 ... 0.5m)	< 1.5mm (at 0 ... 0.5m)
polarizing filter	+	+
short-circuit protection	+	+
reverse polarity protection	+	+
dimensions	15.4x50x50mm	15.4x50x50mm
housing material	zinc diecast	zinc diecast
front screen material	glass	glass
operating temperature	-10 ... +50°C	-10 ... +50°C
degree of protection (EN 60529)	IP67	IP67
connection	2m PVC-cable, 4-wire	M12-connector, 4-pin
connection accessories	-	e.g. VK200325
reflector	AO000006	AO000006
mounting accessories (bracket)	AV000084	AV000084
mounting accessories (universal holder)	AY000119	AY000119

**laser class 1**

according to DIN EN 60825

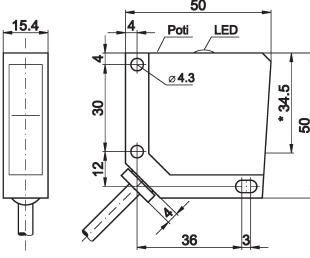
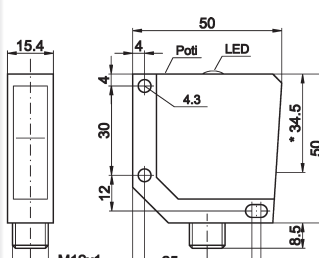
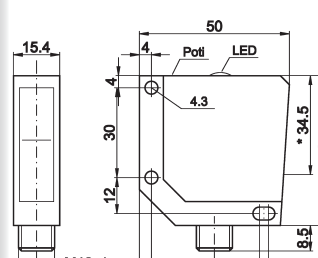

article-no.	PT170400	PT170420	PT170425
version	diffuse reflection sensor background suppression	diffuse reflection sensor background suppression	diffuse reflection sensor foreground suppression
sensing range	25 ... 300mm	25 ... 300mm	25 ... 200mm
connection	cable	connector	connector
	 <p>* transmitter axis: 34.5mm</p>	 <p>* transmitter axis: 34.5mm</p>	 <p>* transmitter axis: 34.5mm</p>
<b>TECHNICAL DATA</b>			
sensing range	25 ... 300mm	25 ... 300mm	25 ... 200mm
output signal	pnp, light-on/dark-on mode	pnp, light-on/dark-on mode	pnp, light-on/dark-on mode
operating voltage	10 ... 30V DC	10 ... 30V DC	10 ... 30V DC
current consumption (w/o load)	≤ 35mA	≤ 35mA	≤ 35mA
output current (max. load)	200mA	200mA	200mA
voltage drop (max. load)	2.0V DC	2.0V DC	1.8V DC
transmitting element (pulsed)	laser diode, red light	laser diode, red light	laser diode, red light
wavelength (transmitter)	650nm	650nm	650nm
laser focus distance	80mm	80mm	80mm
laser class	2	2	2
response/decay time	< 0.6ms	< 0.6ms	< 0.6ms
switching frequency	800Hz	800Hz	800Hz
display (signal/reserve)	yellow LED / -	yellow LED / -	yellow LED / -
sensitivity adjustment *	mechanical, 8 revolutions	mechanical, 8 revolutions	mechanical, 8 revolutions
repeat accuracy	< 0.1mm at the laser focus distance	< 0.1mm at the laser focus distance	< 0.1mm at the laser focus distance
interference suppression	+	+	+
background suppression	+	+	-
foreground suppression	-	-	+
short-circuit protection	+	+	+
reverse polarity protection	+	+	+
dimensions	15.4x50x50mm	15.4x50x50mm	15.4x50x50mm
housing material	zinc diecast	zinc diecast	zinc diecast
front screen material	glass	glass	glass
operating temperature	-10 ... +50°C	-10 ... +50°C	-10 ... +50°C
degree of protection (EN 60529)	IP67	IP67	IP67
connection	2m PVC-cable, 4-wire	M12-connector, 4-pin	M12-connector, 4-pin
connection accessories	-	e.g. <b>VK200325</b>	e.g. <b>VK200325</b>
mounting accessories (bracket)	<b>AV000084</b>	<b>AV000084</b>	<b>AV000084</b>
mounting accessories (universal holder)	<b>AY000119</b>	<b>AY000119</b>	<b>AY000119</b>

3

**Caution! Laser Radiation!**  
**Do not stare into the beam!**

**laser class 2**  
wavelength 650nm  
max. output power < 1mW



### laser beam course

#### retro-reflective sensors

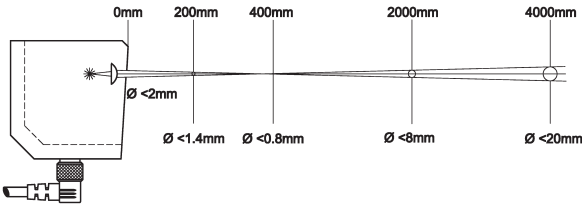

#### diffuse reflection sensors

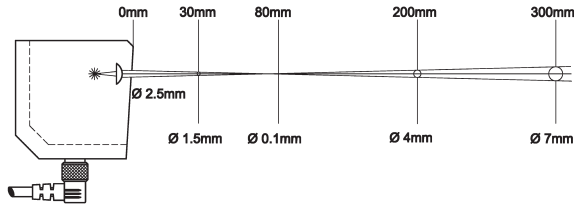

### connection

#### cable device

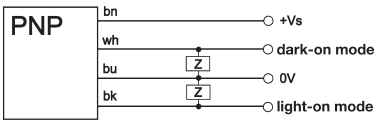

#### connector device

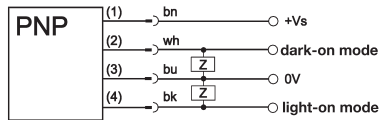

wire colors: bn = brown (1), wh = white (2), bu = blue (3), bk = black (4)

### mounting bracket AV000084 made of galvanized steel

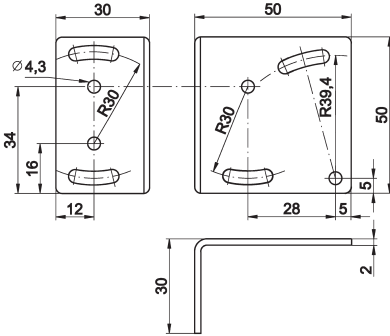

### universal mounting AY000119 consisting of base module ...

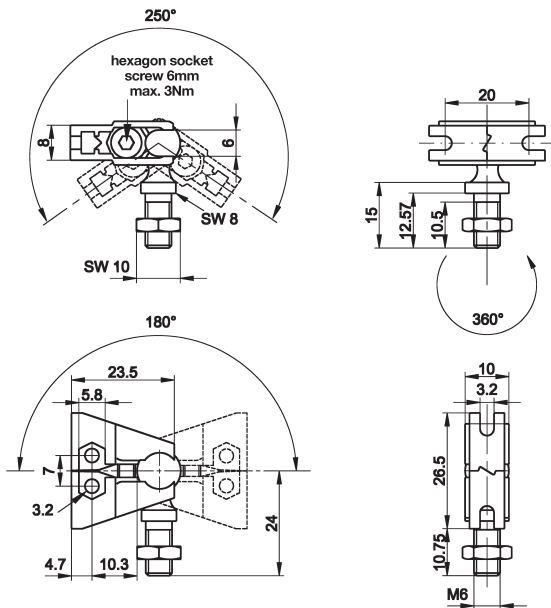

### and fitting panel

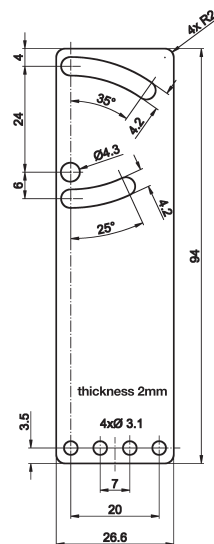

This data sheet contains the standard versions only. Kindly request the availability of other output and connection versions.

We will be pleased to supply the matching cable socket for your devices with connector. Please refer to the list in catalog chapter „accessories“ under „cable sockets **ipf-SENSORFLEX**“ or search our website for „VK“.

**Warning:** Never use these devices in applications where the safety of a person depends on their functionality.

This data sheet as well as your personal contact can be found at [www.ipf-electronic.com](http://www.ipf-electronic.com)