

## PE130175

### LASER SENSORS • THROUGH-BEAM SENSORS RECEIVERS

Optical sensors function contactlessly. They detect objects independent of their characteristics (e.g., shape, color, surface structure, material). The basic operating principle is based on the transmission and reception of light. There are three different versions: 1. The through-beam sensor consists of two separate devices, a transmitter and a receiver that are aligned with one another. If the light beam between the two devices is interrupted, the switching output integrated in the receiver changes its status. 2. With the retro-reflective sensor, the transmitter and receiver are located in one device. The emitted light beam is reflected back to the receiver by a reflector that is to be mounted opposite the device. As soon as the light beam is interrupted, the switching output integrated in the device changes its status. 3. With the diffuse reflection sensor, the transmitter and receiver are in one device. The emitted light beam is reflected by the object that is to be detected. As soon as the receiver detects the reflected light, the switching output integrated in the device changes its status.



#### MECHANICAL DATA

Ambient temperature (MAX)	50 °C
Ambient temperature (MIN)	-20 °C
Aperture diameter	1 mm
Degree of protection (IP)	IP67
Housing coating	Nickel-plated
Housing design	Cuboid
Housing material	Brass
Material of optical surface	Glass
Sensor height	64 mm
Sensor length	14 mm
Sensor width	12 mm
Storage temperature	85 °C

#### ELECTRICAL DATA

Max. output current	100 mA
Measuring range	5 m
No-load current	30 mA
No-load current, receiver	30 mA
Number of pins	3
Operating voltage (MAX)	32 V
Operating voltage (MIN)	12 V
Rated switching distance	5000 mm
Relative repeat accuracy	10 µm
Reverse polarity protection	Yes
Scanning function	Light-/dark-on mode
Short-circuit-proof	Yes
Switching frequency	1000 Hz

## ELECTRICAL DATA

Type of electrical connection	Connector M8
Type of input voltage	DC
Type of switching output	PNP/NPN
Voltage drop	2 V
Voltage type	DC
With LED display	Yes
With LED display (signal)	Yes

## OPTICAL DATA

Filter	Interference filter
Light beam form	Point
Light source	Polarity free red light
Resolution	500 µm
Wavelength of the sensor	670 nm

## OTHER DATA

Scope of delivery of the one-way system	Receiver
---	----------

## CONNECTION

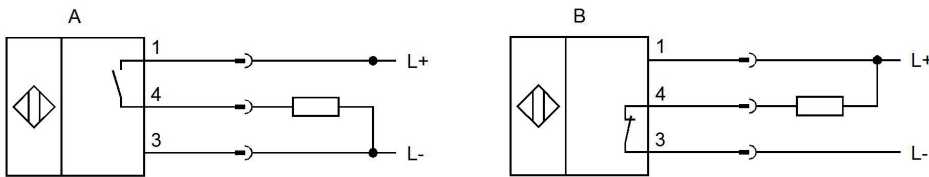

**Colors:** A: 1 = BN (brown), 3 = BU (blue), 4 = BK (black)

B: 1 = BN (brown), 3 = BU (blue), 4 = BK (black) **Functions:** A: 1 = L+, 3 = L-, 4 = PNP NO

B: 1 = L+, 3 = L-, 4 = NPN NC

## DIMENSIONAL DRAWING

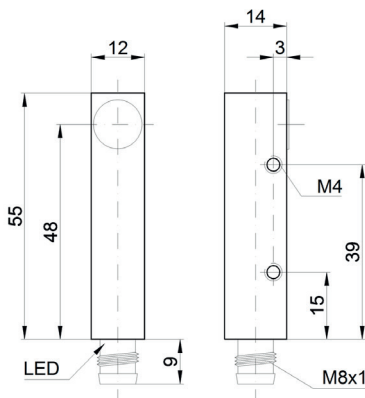

## INSTALLATION



Mounting / Installation may only be carried out by a qualified electrician!

## DISPOSAL



**SAFETY WARNINGS**

Before initial operation, please make sure to follow all safety instructions that may be provided in the product information!

Never use these devices in applications where the safety of a person depends on their functionality.