

SSD370I – SATA III 6Gb/s SSD

Due to Ultra-slim (fit the standard dimensions of 2.5" SATA Hard Disk Drives), huge capacity, SATA 6Gb/s speed, and low power consumption, Solid State Drive is the perfect replacement storage device for Ultrabooks, PCs, Laptops, gaming systems, and handheld devices.

- Fully compatible with devices and OS that support the SATA III 6.0Gb/s standard
- Non-volatile Flash Memory for outstanding data retention
- Supports Trim and NCQ command

Features

- Advanced Global Wear-Leveling and Block management for reliability
- Supports Advanced Garbage Collection
- Features a DDR3 DRAM cache
- Built-in ECC (Error Correction Code) functionality
- Advanced power shield to prevent data loss in the event of a sudden power outage
- Supports Enhanced S.M.A.R.T. Function
- Real time full drive encryption with Advanced Encryption Standard (AES) (Optional)
- RoHS compliant
- Provides great shock resistance
- Slim, elegant and light design



Specifications

Physical Specification			
Form Factor		2.5 inch HDD	
Storage Capacities		32 GB to 1TB	
Dimensions	Length	99.80 ± 0.25 mm	3.929 ± 0.01 inch
	Width	69.80 ± 0.25 mm	2.748 ± 0.01 inch
	Height	7.00 – 0.3 mm	0.276 – 0.012 inch
Input Voltage		5V ± 5%	
Weight		52 ± 2 g	
Connector		SATA 22 pins connector	

Environmental Specifications		
Operating Temperature		- 40 °C to 90 °C
Storage Temperature		- 40 °C to 90 °C
Humidity	Operating	0 % to 95 % (Non-condensing)
	Non-Operating	0 % to 95 % (Non-condensing)

Performance								
Model P/N	ATTO		CrystalDiskMark				IOmeter	
	Max. Read *	Max. Write *	Sequential Read **	Sequential Write **	Random Read (4KB QD32) **	Random Write (4KB QD32) **	IOPS Random Read (4KB QD32) ***	IOPS Random Write (4KB QD32) ***
TS32ASTME0000A	230	40	230	40	90	40	20K	10K
TS64ASTME0000A	450	80	440	80	170	80	40K	20K
TS128ASTME0000A	550	170	520	170	270	170	70K	40K
TS256ASTME0000A	560	320	520	320	300	300	70K	70K
TS512ASTME0000A	560	460	520	460	300	300	75K	75K
TS000ASTME0000A	560	460	520	460	300	300	75K	75K

Note: Maximum transfer speed recorded

* 25 °C, test on ASUS P8Z68-M PRO, 4 GB, Windows® 7 Professional with AHCI mode, benchmark utility ATTO (version 2.41), unit MB/s

** 25 °C, test on ASUS P8Z68-M PRO, 4 GB, Windows® 7 Professional with AHCI mode, benchmark utility CrystalDiskMark (version 3.0.1), copied file 1000MB, unit MB/s

*** 25 °C, test on ASUS P8Z68-M PRO, 4 GB, Windows® 7 Professional with AHCI mode, benchmark utility IOmeter2006 with 4K file size and queue depth of 32, unit IOPS

**** The recorded performance is obtained while the SSD is not operating as an OS disk

Actual Capacity				
Model P/N	LBA	Cylinder	Head	Sector
TS32ASTME0000A	62,533,296	16,383	16	63
TS64ASTME0000A	125,045,424	16,383	16	63
TS128ASTME0000A	250,069,680	16,383	16	63
TS256ASTME0000A	500,118,192	16,383	16	63
TS512ASTME0000A	1,000,215,216	16,383	16	63
TS000ASTME0000A	2,000,409,264	16,383	16	63

Power Requirements		
Input Voltage		5V ± 5% @ 25 °C
Mode P/N / Power Consumption		Typical (mA)
TS32ASTME0000A	Max Write*	180
	Max Read*	175
	Idle*	61
TS64ASTME0000A	Max Write*	255
	Max Read*	238
	Idle*	61
TS128ASTME0000A	Max Write*	384
	Max Read*	241
	Idle*	61
TS256ASTME0000A	Max Write*	621
	Max Read*	255
	Idle*	64
TS512ASTME0000A	Max Write*	643
	Max Read*	285
	Idle*	65
TS000ASTME0000A	Max Write*	692
	Max Read*	352
	Idle*	67

*Tested with IOMeter running sequential reads/writes and idle mode

Reliability		
Data Reliability	Supports 60 bits in 1024 bytes	
MTBF	1,500,000 hours	
Endurance (Terabytes Written)	32 GB	45 (TB)
	64 GB	80 (TB)
	128 GB	150 (TB)
	256 GB	280 (TB)
	512 GB	550 (TB)
	1 TB	1180 (TB)

*Tested under JESD218A endurance test method and JESD219A endurance workloads specification.

Vibration	
Operating	5 G (peak-to-peak), 5 - 800 Hz
Non-Operating	20 G (peak-to-peak), 5 - 800 Hz

* Note: Reference to the IEC 60068-2-6 Testing procedures; Operating-Sine wave, 5-800Hz/1 oct., 1.5mm, 3g, 0.5 hr./axis, total 1.5 hrs.

Shock	
Operating	1500 G, 0.5 ms
Non-Operating	1500 G, 0.5 ms

* Reference to IEC 60068-2-27 Testing procedures; Operating-Half-sine wave, 1500g, 0.5ms, 3 times/dir., total 18 times.

Regulations	
Compliance	CE, FCC and BSMI

Package Dimensions

The figure below illustrates the Transcend 2.5" SATA Solid State Drive. All dimensions are in mm.

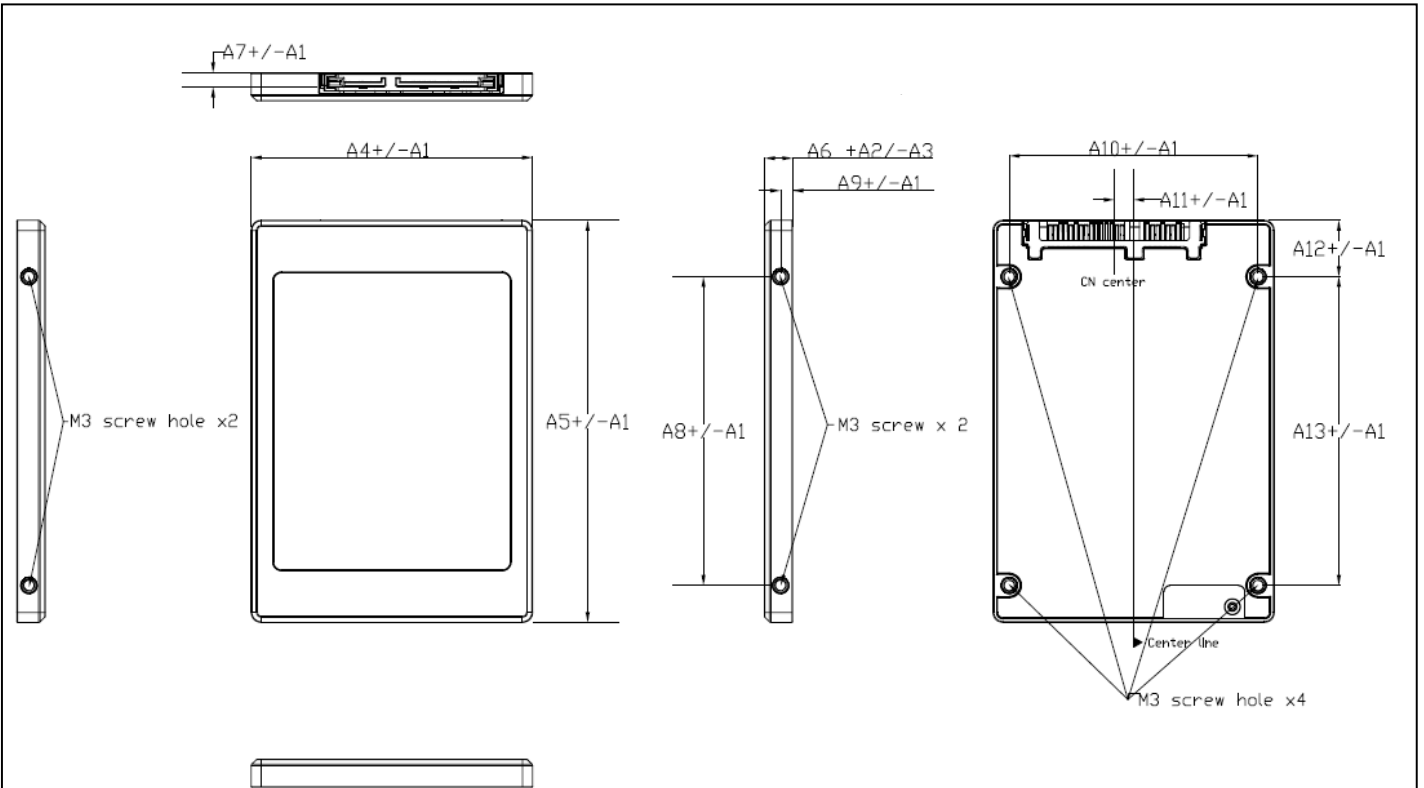

Item	Millimeter	Item	Millimeter
A1	0.25	A11	4.80
A2	0.00	A12	14.00
A3	0.30	A13	76.60
A4	69.80		
A5	99.80		
A6	7.00		
A7	3.5		
A8	76.60		
A9	3.00		
A10	61.72		

*Note: Tighten mounting screws with no more than 2 Kgf-cm of torque.

Pin Assignments

Pin No.	Pin Name	Pin No.	Pin Name
S1	GND	S2	A+
S3	A-	S4	GND
S5	B-	S6	B+
S7	GND	P1	NC
P2	NC	P3	DEVSLP
P4	GND	P5	GND
P6	GND	P7	5V
P8	5V	P9	5V
P10	GND	P11	DAS
P12	GND	P13	NC
P14	NC	P15	NC

Pin Layout

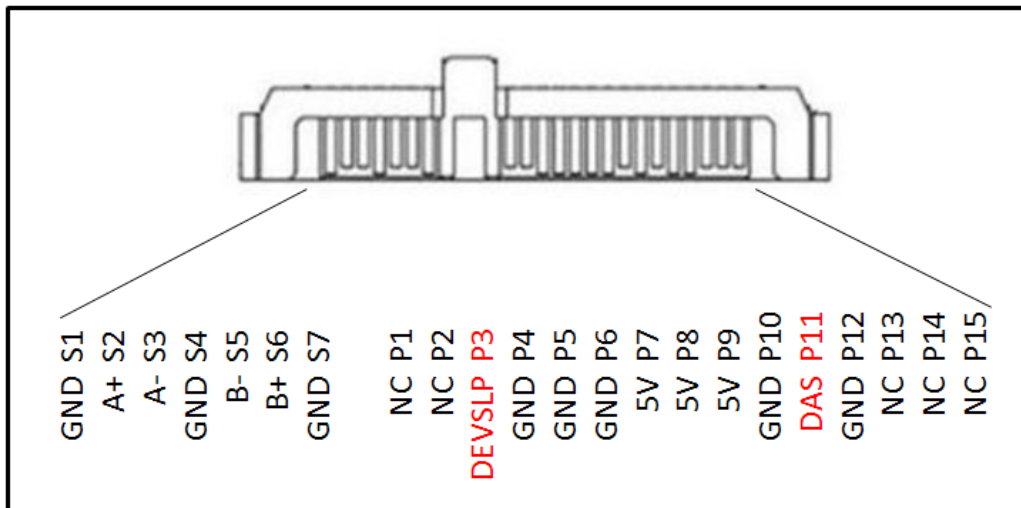

Block Diagram

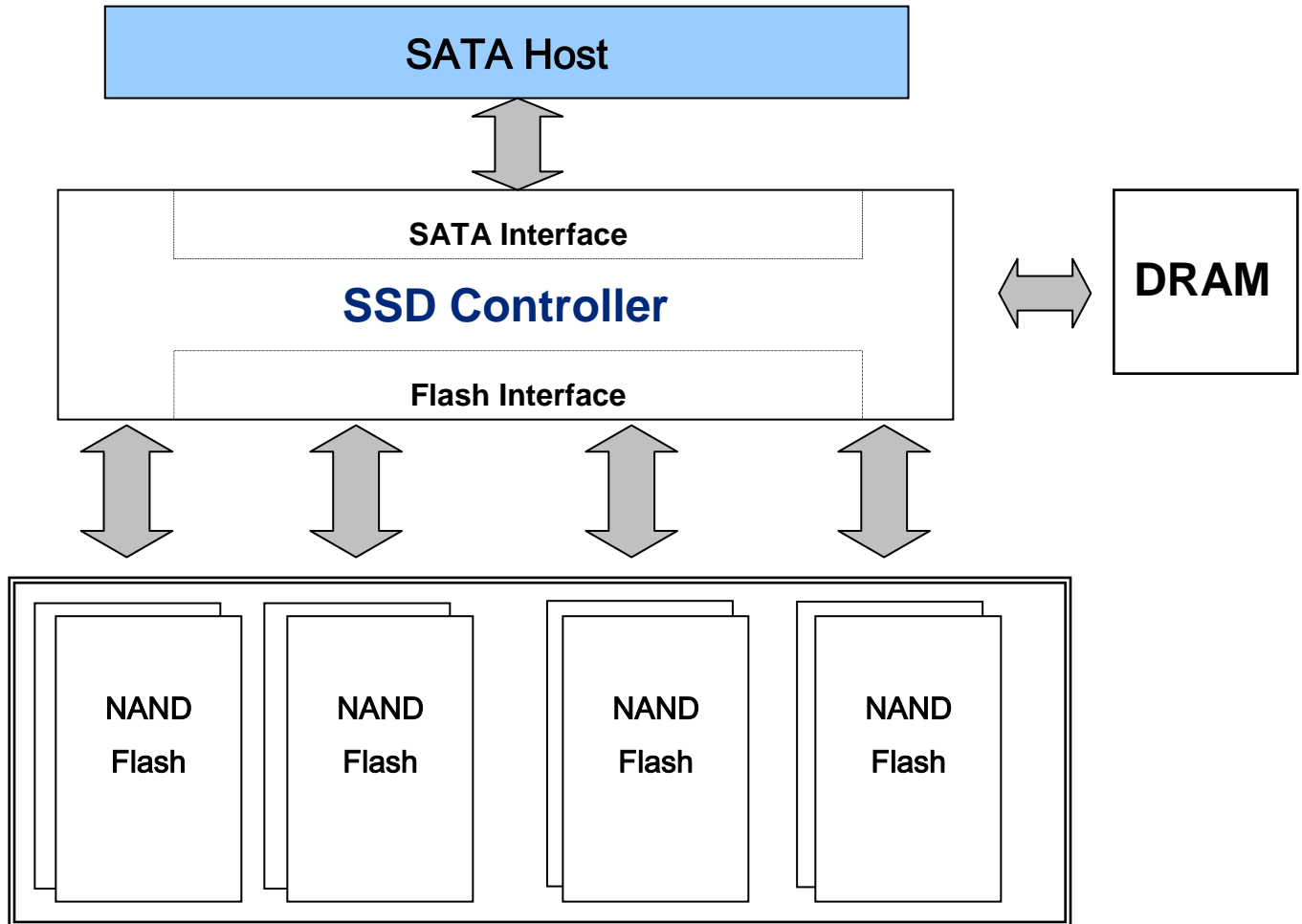

*The quantity of NAND flash varies by capacity.

Features

Wear-Leveling algorithm

The controller supports static/dynamic wear leveling. When the host writes data, the controller will find and use the block with the lowest erase count among the free blocks. This is known as dynamic wear leveling. When the free blocks 'erase count is higher than the data blocks', it will activate the static wear leveling, replacing the not so frequently used user blocks with the high erase count free blocks.

Bad-block management

When the flash encounters ECC fail, program fail or erase fail, the controller will mark the block as bad block to prevent using this block and cause data loss in the future.

Enhanced S.M.A.R.T. function

Transcend's SSDs support the innovative S.M.A.R.T. command (Self-Monitoring, Analysis, and Reporting Technology) that allows the users to evaluate the health information of their SSD in an efficient way.

StaticDataRefresh Technology

Normally, ECC engine corrections are taken place without affecting the host normal operations. As time passes by, the number of error bits accumulated in the read transaction exceeds the correcting capability of the ECC engine, resulting in corrupted data being sent to the host. To prevent this, the controller monitors the error bit levels at each read operation; when it reaches the preset threshold value, the controller automatically performs data refresh to "restore" the correct charge levels in the cell. This implementation practically restores the data to its original, error-free state, and hence, lengthening the life of the data.

ATA Command Register

This table with the following paragraphs summarizes the ATA command set.

Command Table

Support ATA/ATAPI Command	Code	Protocol
General Feature Set		
EXECUTE DIAGNOSTICS	90h	Device diagnostic
FLUSH CACHE	E7h	Non-data
IDENTIFY DEVICE	ECh	PIO data-In
Initialize Drive Parameters	91h	Non-data
READ DMA	C8h	DMA
READ LOG Ext	2Fh	PIO data-In
READ MULTIPLE	C4h	PIO data-In
READ SECTOR(S)	20h	PIO data-In
READ VERIFY SECTOR(S)	40h or 41h	Non-data
SET FEATURES	EFh	Non-data
SET MULTIPLE MODE	C6h	Non-data
WRITE DMA	Cah	DMA
WRITE MULTIPLE	C5h	PIO data-out
WRITE SECTOR(S)	30h	PIO data-out
NOP	00h	Non-data
READ BUFFER	E4h	PIO data-In
WRITE BUFFER	E8h	PIO data-out
Power Management Feature Set		
CHECK POWER MODE	E5h or 98h	Non-data
IDLE	E3h or 97h	Non-data
IDLE IMMEDIATE	E1h or 95h	Non-data
SLEEP	E6h or 99h	Non-data
STANDBY	E2h or 96h	Non-data
STANDBY IMMEDIATE	E0h or 94h	Non-data
Security Mode Feature Set		
SECURITY SET PASSWORD	F1h	PIO data-out
SECURITY UNLOCK	F2h	PIO data-out
SECURITY ERASE PREPARE	F3h	Non-data
SECURITY ERASE UNIT	F4h	PIO data-out
SECURITY FREEZE LOCK	F5h	Non-data
SECURITY DISABLE PASSWORD	F6h	PIO data-out
SMART Feature Set		
SMART Disable Operations	B0h	Non-data
SMART Enable/Disable Autosave	B0h	Non-data
SMART Enable Operations	B0h	Non-data
SMART Execute Off-Line Immediate	B0h	Non-data
SMART Read LOG	B0h	PIO data-In
SMART Read Data	B0h	PIO data-In
SMART Read THRESHOLD	B0h	PIO data-In
SMART Return Status	B0h	Non-data
SMART SAVE ATTRIBUTE VALUES	B0h	Non-data
SMART WRITE LOG	B0h	PIO data-out

Host Protected Area Feature Set		
Read Native Max Address	F8h	Non-data
Set Max Address	F9h	Non-data
Set Max Set Password	F9h	PIO data-out
Set Max Lock	F9h	Non-data
Set Max Freeze Lock	F9h	Non-data
Set Max Unlock	F9h	PIO data-out
48-bit Address Feature Set		
Flush Cache Ext	Eah	Non-data
Read Sector(s) Ext	24h	PIO data-in
Read DMA Ext	25h	DMA
Read Multiple Ext	29h	PIO data-in
Read Native Max Address Ext	27h	Non-data
Read Verify Sector(s) Ext	42h	Non-data
Set Max Address Ext	37h	Non-data
Write DMA Ext	35h	DMA
Write Multiple Ext	39h	PIO data-out
Write Sector(s) Ext	34h	PIO data-out
NCQ Feature Set		
Read FPDMA Queued	60h	DMA Queued
Write FPDMA Queued	61h	DMA Queued
Other		
Data Set Management	06h	DMA
SEEK	70h	Non-data

SMART Data Structure

BYTE	F / V	Description
0-1	X	Revision code
2-361	X	Vendor specific
362	V	Off-line data collection status
363	X	Self-test execution status byte
364-365	V	Total time in seconds to complete off-line data collection activity
366	X	Vendor specific
367	F	Off-line data collection capability
368-369	F	SMART capability
370	F	Error logging capability 7-1 Reserved 0 1=Device error logging supported
371	X	Vendor specific
372	F	Short self-test routine recommended polling time (in minutes)
373	F	Extended self-test routine recommended polling time (in minutes)
374	F	Conveyance self-test routine recommended polling time (in minutes)
375-385	R	Reserved
386-395	F	Firmware Version/Date Code
396-397	F	Reserved
398-399	V	Reserved
400-406	V	TS6500
407-415	X	Vendor specific
416	F	Reserved
417	F	Program/write the strong page only
418-419	V	Number of spare block
420-423	V	Average Erase Count
424-510	X	Vendor specific
511	V	Data structure checksum
<p>F = content (byte) is fixed and does not change.</p> <p>V= content (byte) is variable and may change depending on the state of the device or the commands executed by the device.</p> <p>X= content (byte) is vendor specific and may be fixed or variable.</p> <p>R= content (byte) is reserved and shall be zero.</p>		

SMART Attributes

The following table shows the vendor specific data in byte 2 to 361 of the 512-byte SMART data

Attribute ID (hex)	Raw Attribute Value						Attribute Name
01	MSB	00	00	00	00	00	Read Error Rate
05	LSB	MSB	00	00	00	00	Reallocated sectors count
09	LSB	-	-	MSB	00	00	Reserved
0C	LSB	MSB	00	00	00	00	Power Cycle Count
A0	LSB	-	-	MSB	00	00	Uncorrectable sectors count when read/write
A1	LSB	MSB	00	00	00	00	Number of valid spare blocks
A3	LSB	MSB	00	00	00	00	Number of initial invalid blocks
A4	LSB	-	-	MSB	00	00	Total erase count
A5	LSB	-	-	MSB	00	00	Maximum erase count
A6	LSB	-	-	MSB	00	00	Minimum erase count
A7	LSB	-	-	MSB	00	00	Average erase count
C0	LSB	MSB	00	00	00	00	Power-off retract Count
C2	MSB	00	00	00	00	00	Controlled temperature
C3	LSB	-	-	MSB	00	00	Hardware ECC recovered
C4	LSB	-	-	MSB	00	00	Reallocation event count
C7	LSB	MSB	00	00	00	00	UltraDMA CRC Error Count
F1	LSB	-	-	MSB	00	00	Total LBA written (each write unit = 32 MB)
F2	LSB	-	-	MSB	00	00	Total LBA read (each read unit = 32 MB)
F5	LSB	-	-	MSB	00	00	Total sector write to flash (each write unit = 32 MB)

Revision History

Version	Date	Modification Content
1.0	2014/05/14	Initial release
1.1	2014/08/04	Grammar correction
1.2	2014/11/20	Update features, performance and power consumption
1.3	2015/01/07	Modify torque for mounting screws and power consumption