

SL940020

FLOW SENSORS • SENSORS FOR AIR

The function of the flow sensor is based on the calorimetric principle. The probe is heated up from the inside a few degrees Celsius in relation to the flow medium, in which it protrudes. When the medium flows, the heat generated in the probe is dissipated through the medium. The temperature within the sensor is measured and compared with the likewise measured medium temperature. From the obtained temperature difference the flow state of each medium can be derived. These sensors are applied in areas such as monitoring of cooling systems, ventilation systems, pump dry running by checking the presence of liquid or gas flows.

MECHANICAL DATA

Ambient temperature for evaluation electronics (MAX)	70 °C
Ambient temperature for evaluation electronics (MIN)	-20 °C
Degree of protection (IP) of evaluation electronics	IP65
Degree of protection (IP) of measuring head	IP65
Depth	75 mm
Height	186.9 mm
Housing design	Cuboid
Housing material	Polycarbonate
Medium temperature (MAX)	80 °C
Medium temperature (MIN)	-30 °C
Pressure resistance	16 bar
Sensing element material	Stainless steel 1.4301
Temperature medium (MAX)	80 °C
Temperature medium (MIN)	-30 °C
Type of process connection	R1 1/2
Width	475 mm

ELECTRICAL DATA

Air conditioning / ventilation systems	Yes
Flow measurement	Yes
Flow range for air	16.66 l/min
Flow range for air	12166.66 l/min
Max. output current	150 mA
Measuring head integrated in device	Yes
Measuring principle of flow	Calorimetric
No-load current	120 mA
Number of pins	5
Number of switching outputs	1
Number of switching points	2
Operating voltage (MAX)	36 V
Operating voltage (MIN)	18 V

ELECTRICAL DATA

Pressure resistance of measuring head	16 bar
Rated control supply voltage U_s at DC (MAX)	36 V
Rated control supply voltage U_s at DC (MIN)	18 V
Reverse polarity protection	Yes
Setting procedure	Parameterization
Short-circuit-proof	Yes
Switching current	0.15 A
Switching voltage	48 V
Transistor output	Yes
Type of analog output	4 mA ... 20 mA
Type of electrical connection	Plug-in connection M12
Type of switching function	Normally open contact (NO)
Type of switching output	Relay contact
Voltage type	DC
With display	Yes
With LED display	Yes

OTHER DATA

For pneumatic applications	Yes
Suitable for gases	Yes
Suitable for liquids	No

CONNECTION

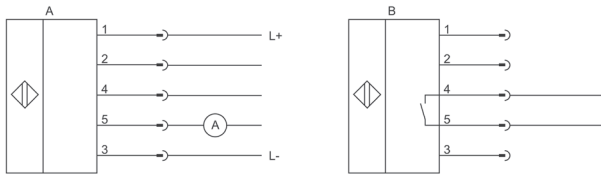

Colors: A: 1 = BN (brown), 2 = WH (white), 3 = BU (blue), 4 = BK (black), 5 = GY (gray)

A: 1 = BN (brown), 2 = WH (white), 3 = BU (blue), 4 = BK (black), 5 = GY (gray) **Functions:** A: 1 = L+, 2 = RS485 / Modbus (A), 3 = L-, 4 = RS485 / Modbus (B), 5 = 4-20mA

B: 1 = n.c., 2 = n.c., 3 = n.c., 4 = pulse (galv. insulated), 5 = pulse (galv. insulated)

DIMENSIONAL DRAWING

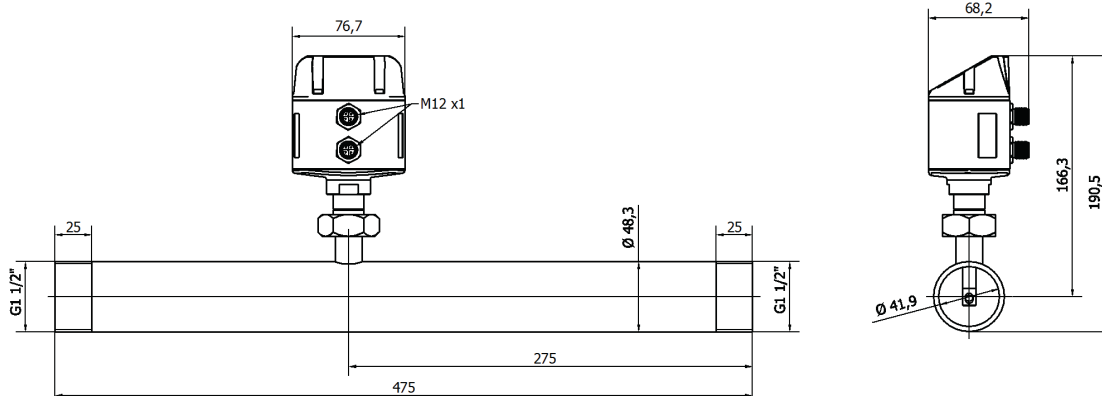

INSTALLATION



Mounting / Installation may only be carried out by a qualified electrician!

DISPOSAL



SAFETY WARNINGS

Before initial operation, please make sure to follow all safety instructions that may be provided in the product information!

Never use these devices in applications where the safety of a person depends on their functionality.