

MZA70186

MAGNETIC SENSORS • SENSORS FOR PNEUMATIC CYLINDERS

For many tasks in the field of automation technology, it is necessary to recognize the motional processes in pneumatic and hydraulic cylinders and to detect the position of the piston with precision. For this, magnetic cylinder sensors are used.

MECHANICAL FEATURES

Ambient temperature	-25 °C ... 70 °C
Cable length	0.3 m
Degree of protection (IP)	IP67
Housing design	Cuboid
Housing material	Zinc die-cast
Increased ambient temperatures > 80°C	-
Material of cable sheath	PTFE
Max. tightening torque	0.1 Nm
Metal housing	+
Mounting access, cylinder groove	From the top
Sensor height	4.3 mm
Sensor length	19 mm
Sensor surface position	Center of the device
Sensor width	6.15 mm
Strong vibration / motion	+
Version	6.2mm T-groove

ELECTRICAL FEATURES

Cross/short circuit identification possible	-
Hysteresis	1 mm
Low sensitivity	-
Low switching hysteresis	+
Magnetic sensitivity	2.8 mT
Max. output current	150 mA
No-load current	15 mA
Number of pins	3
Number of switching outputs	1
Operating voltage	10 V ... 30 V
Reed contact	-
Relative repeat accuracy	0.1 mm
Reverse polarity protection	+
Sensor surface (active)	Middle area
Setting via teach-in	-

ELECTRICAL FEATURES

Short-circuit protection	+
Suitable for safety functions	-
Switching frequency	1000 Hz
Two switching points	-
Type of electrical connection	Cable connector M8
Type of switching function	Normally open contact
Type of switching output	PNP
Voltage drop	2 V
Voltage type	DC
With LED display	+
With monitoring function of downstream devices	-

OTHER FEATURES

Cylinder sensors	+
Cylinder version	With T-groove
For T-groove	Yes
Harsh environmental conditions	+
Metallic sensor surface	-
Oil and cooling lubricants	+
Short travel path	-

Other

Packaging dimensions	100mm x 17.0mm x 120mm
Shipping weight	0.01kg
Tariff code	85365019

Classification

ipf product group	220
eClass 8.0	27270105
eClass 9.0	27270105
eClass 9.1	27270105
ETIM-5.0	EC002544
ETIM-6.0	EC002544
ETIM-7.0	EC002544

Connection

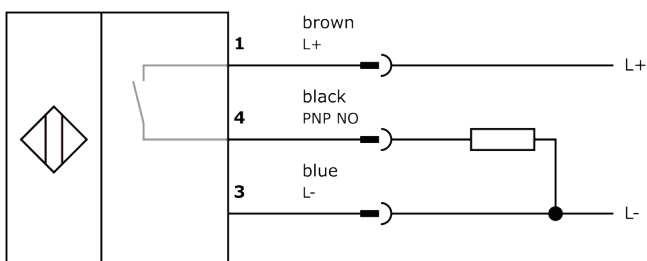

Dimensional drawing

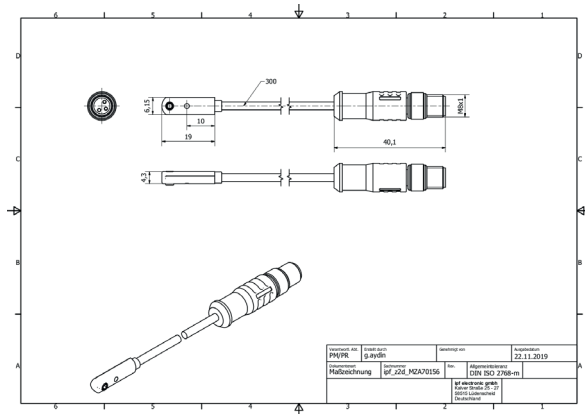

Installation



Mounting / installation may only be carried out by a qualified electrician!

Disposal



Software

Please download the software or driver required for operating your new device on our homepage: www.ipf.de

Safety warnings

Before initial operation, please make sure to follow all safety instructions that may be provided in the product information.

Never use these devices in applications where the safety of a person depends on their functionality.

LED lighting systems can generate intensive UV radiation, which can damage your eyes in case of improper use. The manufacturer cannot be held responsible for damages that result from improper use or connection.