

**Technical Data**

operating voltage $U_B$	10 ... 30V DC, short-circuit and reverse polarity protected
no-load current	< 50mA
switching output	pnp, NO (dark-on mode)
ampacity	100mA
voltage drop	$\leq 2.2V$
operating range	10m
range limit	11m
response / decay time	$\leq 0.25ms$
sending element	laser diode red, 670nm, pulsed
repeat accuracy	< 0.1mm at laser focus
display soiling / misalignment	LED yellow flashing
receiving display	LED yellow
operating mode display	LED green
ambient temperature	-10 ... +50°C
protection class	IP67 acc. EN 60529
housing material	plastic (PA12)
max. tightening torque	1Nm
electrical connection	M8-connector 4-pin

**Connection**
**Dimensional drawing**

bn=brown, wh=white, bk=black, bl=blue  
terminal marking of cable sockets in brackets

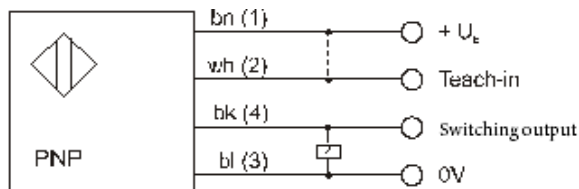
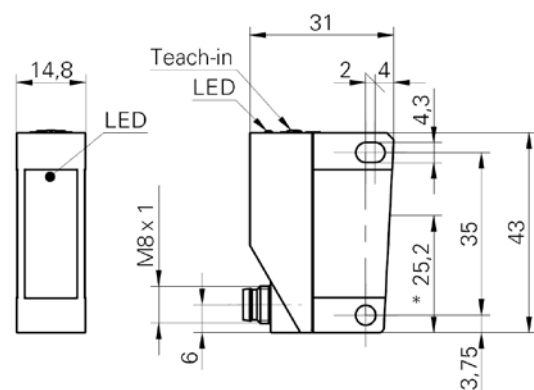

\* transmitter and receiver axis

**Warning!**

Laser radiation  
Do not look into the beam!  
Laser diode  
Wave length 650nm  
Max. output power < 25 $\mu$ W  
Laser class 1  
Never point the laser beam into eyes!

**Laser class 1**

according to DIN EN 60825-1



---

## Mounting and adjustment

---

The laser retro-reflective sensor can be mounted by mounting bracket AO000082 as well as directly with M4-screws.

Mount the reflector perpendicularly to the laser beam (max. tilt  $\pm 5^\circ$ ). The laser beam should impinge centrally at the reflector.

For cleaning the front screen please use a clean (!), soft and dry cloth. In case of severe soiling moisten the cloth with pure alcohol.

---

## Teach-In

---

The teach process has to be performed within 60sec. Otherwise the device changes automatically to the normal operating mode with the former settings.

1. Press the teach button for approx. 2sec. The yellow LED starts flashing and the switching output switches.
2. Align the sensor on the reflector and press the teach button shortly.
3. Place the object to be detected between sensor and reflector and press the teach button shortly.
4. In case of a successfully performed teach process the yellow LED lights up for approx. 2sec. During this time the switching output is not active.
5. If the teach process was not successful, the yellow LED flashes quickly for approx. 2sec. At the same time the switching output is switched off. This happens when the difference between the teach points is too small for a safe application or the sensor was taught at its range limit.

You can perform the teach process also via an external teach-wire. Instead of pressing the button please connect the white wire with  $+U_B$ .

**Note:** During normal operation the LED will light up if the light path is free. If the light path is interrupted by an object, the output will switch and the LED will be switching off.

Article number: **PR430170**

appropriate mounting bracket: **AO000082**

appropriate universal holder: **AY000120**

appropriate cable socket: e.g. **VK200375**

**Warning:** Never use these devices in applications where the safety of a person depends on their functionality.