

FV565901

FILLING LEVEL SENSORS • SWITCHING AMPLIFIERS

Filling level and level sensors operate according to different measuring principles. The selection of the sensor depends on the medium to be detected and the ambient conditions. The material flow in a vibratory bowl can be excellently queried with inductive filling level sensors whose pendulum is moved by the material in the pot. The detection of liquid or solid media is, for instance, possible with capacitive filling level sensor technology. These work according to the principle of the condensator, the medium changes the dielectricity between two electrodes. The resulting change is converted into a digital output signal. A further alternative for the detection of filling levels of conductive media is provided by conductive filling level relays. The resistance between reference and measuring electrode is determined. If a set threshold is exceeded, a relay output switches.



MECHANICAL DATA

Degree of protection (IP)	IP20
Depth	114.5 mm
Device design	Field device
Height	99 mm
Housing design	Cuboid
Housing material	Polyamide
Length	114.5 mm
Mounting method	DIN rail
Width	22.5 mm

ELECTRICAL DATA

Conductive filling level amplifiers	Yes
Galvanic isolation between input and output	No
Galvanic isolation between inputs	No
Galvanic isolation between supply voltage and all other current circuits	No
Inherently safe according to EN 60947-5-6 NAMUR	No
Malfunction message output	No
Number of channels	2
Output circuit, relay change-over contact	2
Power consumption	10 W
Rated supply voltage at AC (MAX)	253 V
Rated supply voltage at AC (MIN)	20 V
Rated supply voltage at DC (MAX)	253 V
Rated supply voltage at DC (MIN)	20 V
Reverse polarity protection	Yes
Suitable for safety functions	No
Switching capacity	2500 VA
Switching current	10 A
Switching voltage	250 V

ELECTRICAL DATA

Type of electrical connection	Clamp
Type of voltage supply	Active
With LED display	Yes

OTHER DATA

Operating temperature (MAX)	70 °C
Operating temperature (MIN)	-40 °C

DIMENSIONAL DRAWING

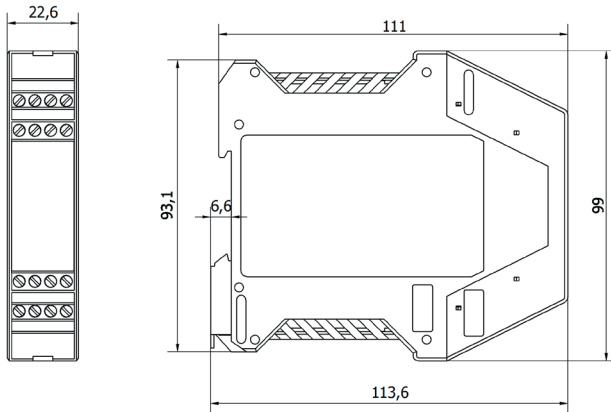

INSTALLATION



Mounting / Installation may only be carried out by a qualified electrician!

DISPOSAL



SAFETY WARNINGS

Before initial operation, please make sure to follow all safety instructions that may be provided in the product information!

Never use these devices in applications where the safety of a person depends on their functionality.