

dimensions **30 x 90 x 70mm**
dif. reflection sensors adjustable **300 to 6000mm**

- ✓ reflection-independent distance information up to 6000mm
- ✓ highly insensitive to ambient light
- ✓ 2 push-pull switching outputs
- ✓ analog current output
- ✓ configuration via LED display and membrane keyboard
- ✓ measurement value display in mm on LED display
- ✓ configurable measuring range and mode
- ✓ 5-pin M12-connector
- ✓ robust metal housing made of zinc diecast

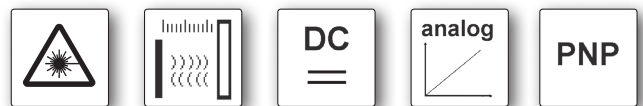

time-of-flight distance measurement versatile programming



description

With the time-of-flight measurement method, the distance of an object is determined using the propagation time of a light pulse emitted by the sensor transmitter, reflected by the object and then received by the sensor receiver. The measurement principle is suitable for large ranges with simultaneous immunity to ambient light interference and a low influence of gloss and structures on the measurement value. The measurement time can be adjusted via key pad and LED display and is consistent. The measuring range is 300 to 6,000mm; with highly reflective surfaces, values of up to 10,000mm can be shown in the display. The devices are equipped with an integrated RISC controller for short measuring times with simultaneously

high precision of the measured values. The high-performance hardware is also able to preprocess measurement data in the sensor. Integrated in the device are a membrane keyboard and an LED display via which the **PT700523** can be configured with the aid of a graphical menu. In measurement operation, the display shows the current measured value. The sensor can be protected against unauthorized operation by means of the lockable cover on the rear of the device and password protection.

application examples

- ▶ sag monitoring for web material



article-no.	PT700523
sensing range	300 ... 6000mm

- A green display mode
- B yellow display mode
- C transmitter
- D receiver
- E optical axis
- F connector M12x1
- G 4.2 deep counterbore for M5 hexagon-nut
- H parameterizing connector
- I reference edge for measurement (cover glass)

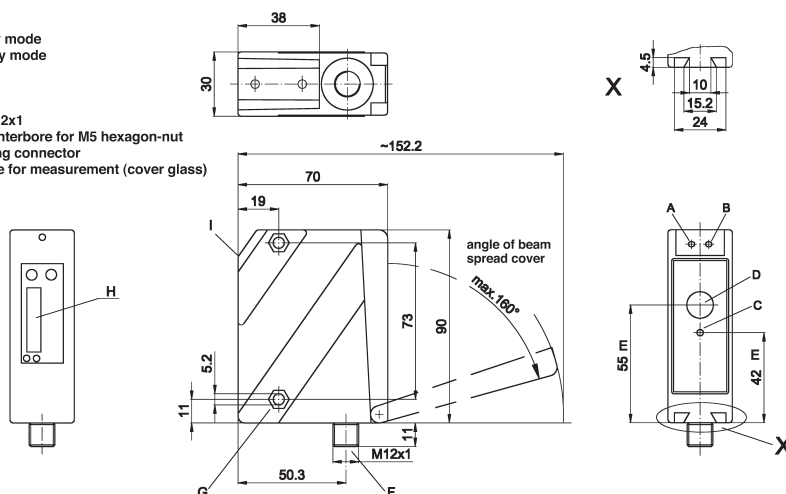

TECHNICAL DATA

measuring range	300 ... 6000mm (6 ... 90% diffuse reflection)
resolution	3mm
output signal	switching outputs: push-pull ¹⁾ / analog output: 4 ... 20mA ≤ 500Ω
operating voltage	18 ... 30V DC
current consumption (w/o load)	≤ 150mA
output current (max. load)	100mA per switching output
load resistance	see above
transmitting element	red laser diode, pulsed
wavelength	658nm
laser class	2
light spot size	2x7mm ² at a distance of 10000mm
readiness delay	< 300ms
measuring time	operational mode= fast: 1.4ms, standard: 10ms, precision: 50ms (factory setting)
response time	< 300ms
display (signal)	yellow LED
display (operation)	green LED
adjustment	membrane keyboard
short-circuit protection	+
reverse polarity protection	+
dimensions	30x90x70mm
housing material	zinc diecast
front screen material	glass
operating temperature	-40 ... +50°C
storage temperature	-30 ... +70°C
degree of protection (EN 60529)	IP67
connection	M12-connector, 5-pin
connection accessories	e.g. VK505621
mounting accessories	transverse mounting: AP000023 lengthwise mounting: AP000024 profile fixing: AP000025

1) the push-pull switching outputs must not be connected in parallel

For additional technical data, see the operating instructions!

Note: After an operating period of 20 minutes, the device has reached the operating temperature required for optimum measurement!

connection

PT700523

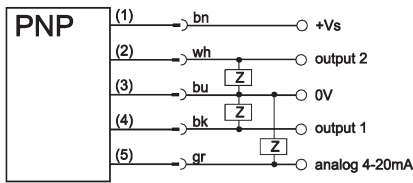

wire colors: bn = brown (1), wh = white (2), bu = blue (3),
bk = black (4), gy = gray (5)

Warning

Caution! Laser Radiation!
Do not stare into the beam!

laser class 2

according to DIN EN 60825
wavelength 658nm
max. output power 1mW



analog output characteristic curve

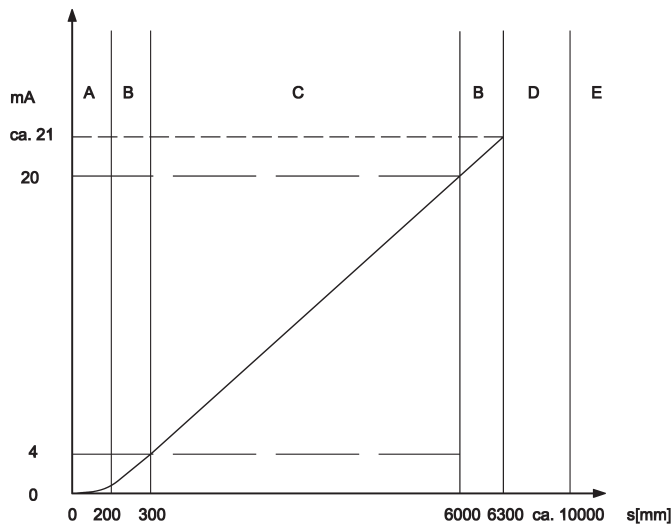

Warning

- A undefined area
- B linearity undefined
- C measuring range
- D object present
- E no object detected

LED indicators

green LED	continuous light	ready
	flashing	interference
	off	no supply voltage
yellow LED	continuous light	object in the programmed measuring range of output 1
	off	object outside of the programmed measuring range of output 1



mounting bracket

AP000023 crosswise mounting

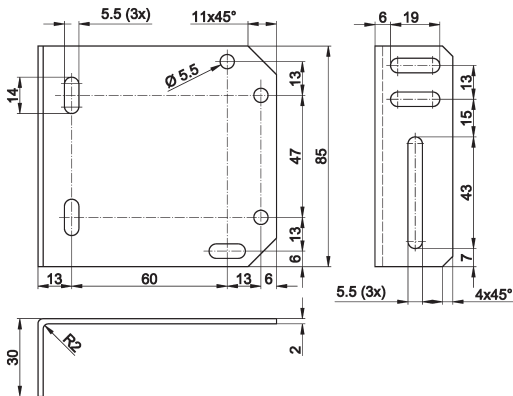

AP000024 lengthwise mounting

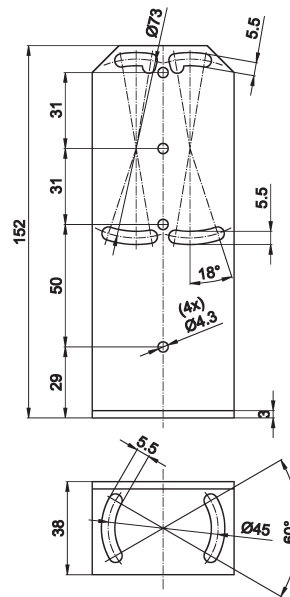

AP000025 profile fixing

lateral mounting

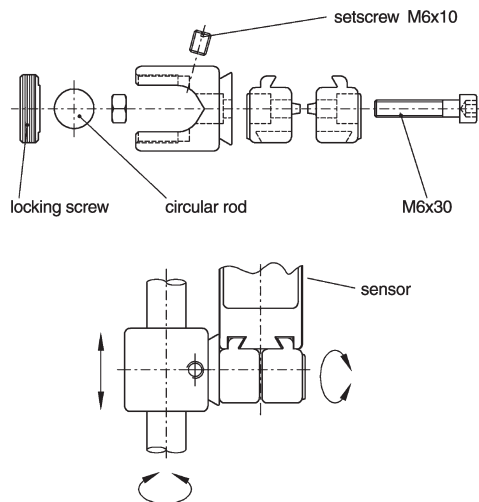

crosswise mounting

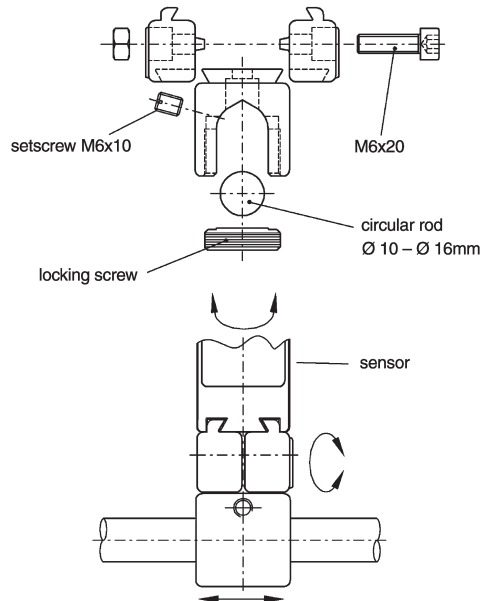

ACCESSORIES

article-no.	description	note
AP000023	bracket for transverse mounting	metal
AP000024	bracket for lengthwise mounting	metal
AP000025	profile fixing	metal

This data sheet contains the standard versions only. Kindly request the availability of other output and connection versions.

We will be pleased to supply the matching cable socket for your devices with connector. Please refer to the list in catalog chapter „accessories“ under „cable sockets **ipf**-SENSORFLEX®“ or search our website for „VK“.

Warning: Never use these devices in applications where the safety of a person depends on their functionality.

This data sheet as well as your personal contact can be found at www.ipf-electronic.com