

# Manual for PT740020/21



## Contents

<b>1</b>	<b>General information.....</b>	<b>3</b>
1.1	Concerning the contents of this document .....	3
1.2	Intended use .....	3
1.3	Safety warnings .....	3
<b>2</b>	<b>Commissioning.....</b>	<b>4</b>
<b>3</b>	<b>Connection .....</b>	<b>8</b>
3.1	Connection cable .....	8
3.2	Pin assignment and connection diagram.....	9
<b>4</b>	<b>Installation .....</b>	<b>10</b>
4.1	Mounting .....	10
4.2	Sensor reference level.....	10
4.3	Measuring field definition.....	11
4.4	Mounting: .....	13
4.5	Installation accessories.....	14
<b>5</b>	<b>Configuration .....</b>	<b>15</b>
5.1	Overview of control elements .....	15
5.2	Function tree .....	18
5.3	LIVE MONITOR .....	19
5.4	MEAS TYPE .....	21
5.5	OBJECT .....	22
5.6	PRECISION .....	22
5.7	FIELD OF VIEW .....	25
5.8	ANALOG OUT .....	27
5.9	DIGITAL OUT.....	29
5.10	SYSTEM .....	31
5.11	SETTING .....	33
<b>6</b>	<b>Function and definition.....</b>	<b>34</b>
6.1	Sensors data sheet.....	34
6.2	Functional principle.....	39
6.3	Measuring repetition time and response time.....	41
6.4	Hysteresis .....	42
6.5	Object to be measured .....	44
6.6	Inputs and outputs .....	45
6.7	Touch panel.....	53
6.8	Memory.....	53
6.9	Standard deviation.....	54
<b>7</b>	<b>Safety instructions and maintenance.....</b>	<b>55</b>
7.1	General safety instructions .....	55
7.2	Part identification .....	55
7.3	Influence of ambient light.....	57
7.4	Front (optics).....	57
7.5	Cleaning the sensors .....	57
7.6	Disposal .....	57
<b>8</b>	<b>Error correction and tips.....</b>	<b>58</b>
8.1	Examples of sensor setup .....	58
8.2	Error correction .....	59

# 1 General information

## 1.1 Concerning the contents of this document

This manual contains information about the installation and initial setup of the ipf PT740020/21 light section sensors.

It is a supplement to the mounting instructions supplied with each sensor.



Read these operating instructions carefully and follow the safety instructions!

## 1.2 Intended use

The PT740020/21 measures distances to objects. It was especially developed for easy handling, flexible use, and precise measurement.

## 1.3 Safety warnings



### NOTE

Provides helpful operation instructions or other general recommendations.



### ATTENTION!

Indicates a possibly hazardous situation. If it is not avoided, minor or slight injuries can occur or the device can be damaged.

## 2 Commissioning

After the sensor is connected and installed, configure it via the display and perform the other application-specific settings/measurement type within these functions. The sensor is then ready for operation and outputs the measuring value in mm to the screen. Optionally, the measuring field can be limited or the switching output can be configured.

1	Connection
2	Installation
3	Application specific settings
	Optional settings
4	Let's get started

### 1 Connection

Connect the sensor according to the connection diagram. A shielded connection cable (8-pole M12) must be used.

When everything is correctly connected, the sensor starts up.

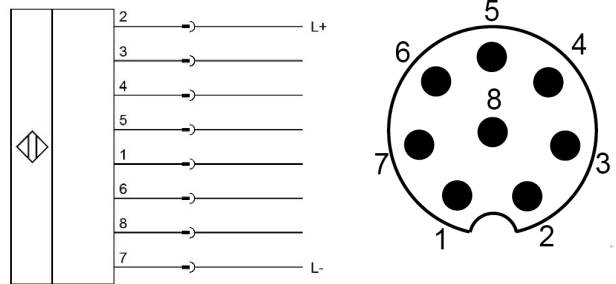

Functions: 1 = n. c., 2 = L+, 3 = 4-20mA/0-10V, 4 = Push Pull, 5 = Alarm Push Pull, 6 = n. c., 7 = L-, 8 = Sync-In

Colors: 1 = WH (white), 2 = BN (brown), 3 = GN (green), 4 = YE (yellow), 5 = GY (gray), 6 = PK (pink), 7 = BU (blue), 8 = RD (red)

#### Key functions

- ESC = Back
- ESC 2 sec. = Run mode
- UP = Up/increase value
- DOWN = Down/decrease value
- SET = OK
- SET 2 sec. = Save value

Slide over all 4 keys:

- > = Enables the panel if locked
- <---- = Jump to run mode



#### Setting the language

The language is selected and confirmed by pressing SET for 2 seconds.

- English
- Deutsch
- Italiano
- Français

## 2 Installation

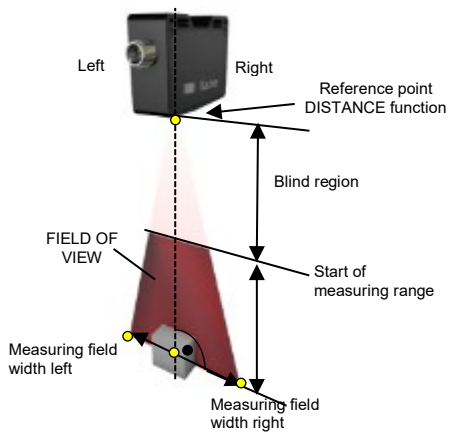

The sensor is aligned at a right angle to the measurement axis. The object must be within the measuring field, i.e. between the start of the measuring range  $S_{dc}$  and the end of the measuring range  $S_{de}$ .

**3 Application specific settings**

**3a**

**Distance**

*Distance measurement to an object*

For a distance measurement, the required MEAS TYPE (average value, maximum or minimum) can be selected. The front plane of the sensor (R2) serves as reference surface (zero).

- Avg DIST<sup>1</sup>** = Average value of all measured points
- Max DIST** = Distance to the furthest measuring point
- Min DIST** = Distance to the closest measuring point

LIVE MONITOR			
▽			
MEAS TYPE		Avg DIST	
		Max DIST	
		Min DIST	
△ ▽			
OBJECT		Bright	
		Dark	
△ ▽			
PRECISION		Standard	
		High	
		Very High	
△ ▽			
FIELD OF VIEW		LIMIT LEFT	Value in mm
		LIMIT RIGHT	Value in mm
		Set max values	
△ ▽			
ANALOG OUT		SCALE OUT	DIST NEAR
			Value in mm
			DIST FAR
			Value in mm
		Set max values	
△ ▽			
		ANALOG OUT	Current / Voltage
		CHARACTERISTIC	Pos. slope / Neg. slope
DIGITAL OUT		DIGITAL OUT	Point / Window
		SWITCH POINT	Value in mm
		WINDOW P1	Value in mm
		WINDOW P2	Value in mm
		OUTPUT LEVEL	Active high / Active low
△ ▽			

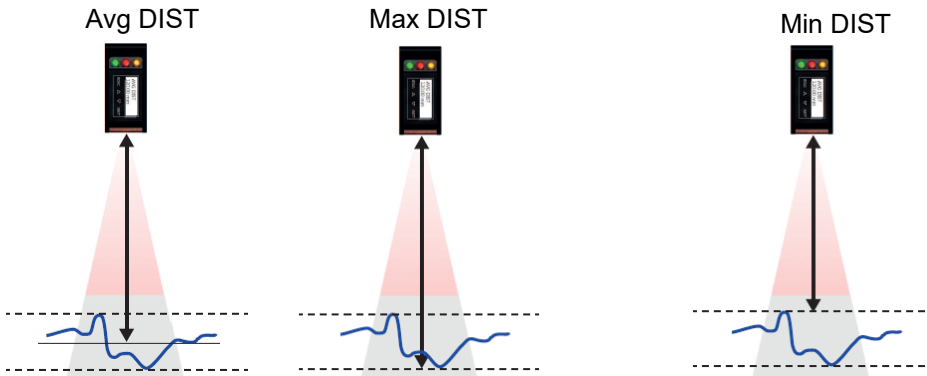

<sup>1</sup> In the factory settings Avg DIST is predefined

## Optional settings

### OBJECT

Selection of bright or dark objects to optimize the measurement results.

### PRECISION

To achieve better precision and resolution, it is possible to alternate between Standard, High and Very High by filtering the output values.

### FIELD OF VIEW

The width of the measuring field can be changed with FIELD OF VIEW. Separate configuration of the single points of the field: LIMIT LEFT, LIMIT RIGHT.

This function is required when there are objects in the measuring field that should not be detected.

### ANALOG OUT

Start of measuring range Sdc and end of measuring range Sde can be changed with SCALE OUT. 0V or 4mA then apply for the start of measuring range Sdc. 10V or 20 mA apply for the point at the end of measuring range Sde. Voltage and current output is selected under ANALOG OUT. In addition, the output curve can be inverted under OUTP. SLOPE.

### DIGITAL OUT

The sensor is equipped with a switching output that can be configured as a threshold or as a window via the DIGITAL OUTPUT function.

Threshold: As soon as the measuring value is greater than the entered threshold, the switching output will be changed.

Window: As soon as the measuring value is outside the entered window, the switching output will be changed.

## 4 Let's get started

The sensor continuously outputs the measuring value in mm to the display and transmits it via the analog output to the control.

### 3 Connection

**ATTENTION!**

Incorrect supply voltage will destroy the device!

**ATTENTION!**

Connection, installation and commissioning may only be performed by qualified personnel.

**ATTENTION!**

The IP protection class is valid only if all connections are connected as described in the technical documentation.

**ATTENTION!**

Laser class 1 laser beam according to EN 60825-1:2007. This product can be operated safely without any additional safety precautions. Nevertheless direct contact between the eye and beam should be avoided.

#### 3.1 Connection cable

An 8-pole, shielded connection cable (connector) is required.

These ipf connection cables with the following order codes are recommended:

- VK205A21/25 (length 2 m, M12 socket angled/straight)
- VK505A21/25 (length 5 m, M12 socket angled/straight)
- VKA05A21/25 (length 10 m, M12 socket angled/straight)

Other cable lengths are available.

When using the analogue output, the cable length has an influence on the signal noise. The longer the cable, the greater the signal noise.

**Analog output I\_OUT**

Noise: 5.92  $\mu$ A (1 Sigma) (10 m cable and 680 ohm)

3:59  $\mu$ A (1 sigma) (2m cable and 680 ohm)

**Analog output U\_OUT**

Noise: 4.80 mV (1 Sigma) (10m cable and 100 kOhm)

3:03 mV (1 Sigma) (2m cable and 100 kOhm)

### 3.2 Pin assignment and connection diagram

Pin	Color	Function	Description
Pin 1	WH = white	n.c.	Not connected
Pin 2	BN = brown	+ Vs	Voltage supply (+15...+28 VDC)
Pin 3	GN = green	analog	Analog output (4...20 mA or 0...10V)
Pin 4	YE = yellow	out	Switching output, push-pull
Pin 5	GY = gray	alarm	Alarm output, push-pull
Pin 6	PK = pink	n.c.	Not connected
Pin 7	BU = blue	0V	Ground GND
Pin 8	RD = red	sync in	Input synchronization

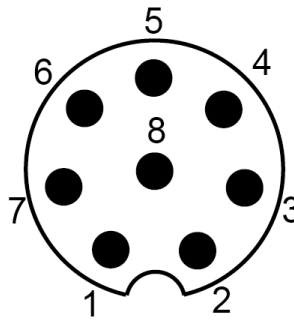
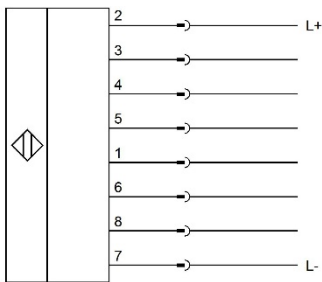

**NOTE**

It is recommended to connect unused inputs to GND (0V).

## 4 Installation



### ATTENTION!

Connection, installation and commissioning may only be performed by qualified personnel. Protect optical surfaces from moisture and dirt.

### 4.1 Mounting

The sensor has four mounting holes for flexible alignment and mounting. The use of 2 M4x35 screws is recommended for mounting. The tightening torque is max. 1.2 Nm.

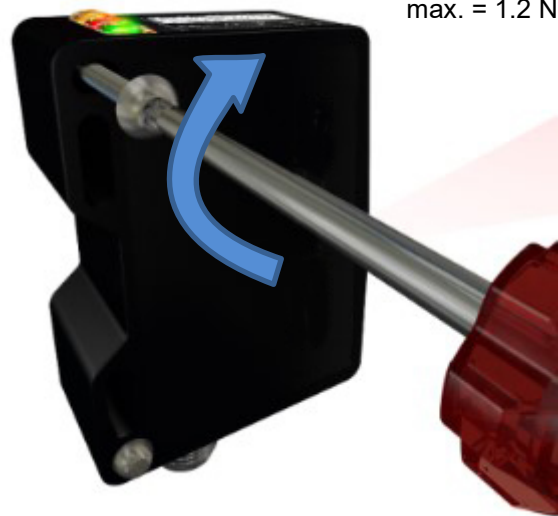

Tightening torque  
max. = 1.2 Nm

### 4.2 Sensor reference level

The sensor can be aligned with the following levels:

The laser beam of the sensor runs parallel ( // ) to level R3 and is at a right angle to levels R1 and R2. Levels R1, R2, and R3 serve as references for sensor alignment during installation. "Left" and "Right" designations are also important.

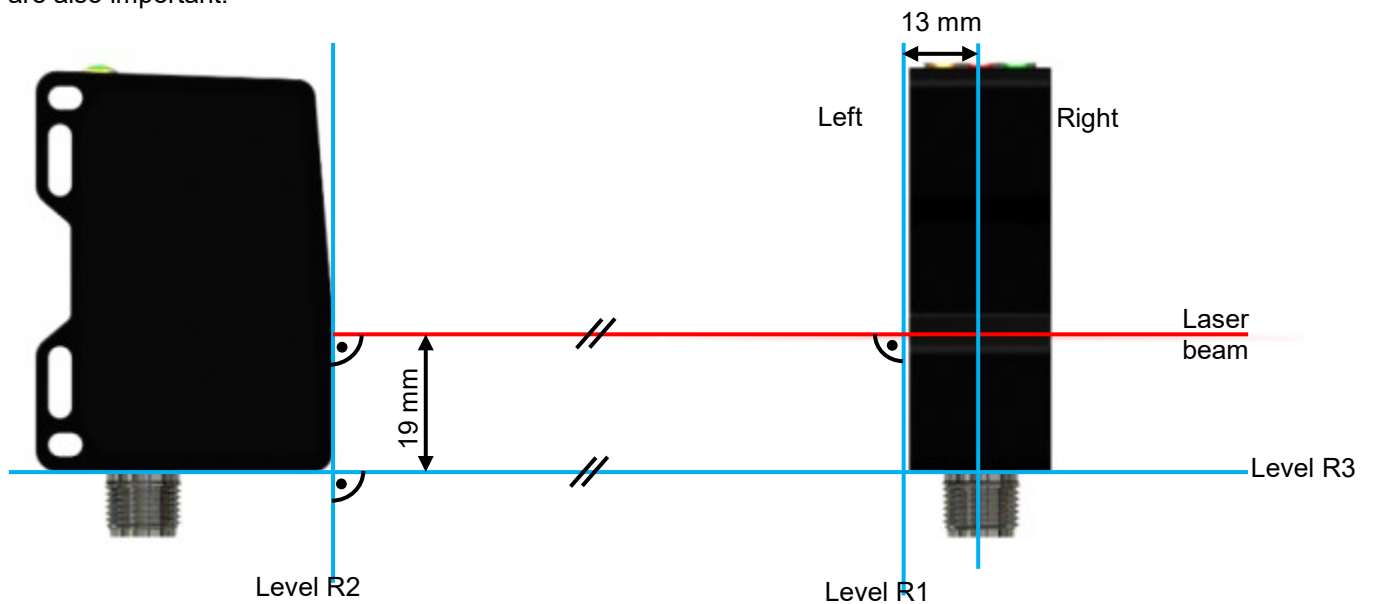

### 4.3 Measuring field definition

The maximum measuring field and additional important measuring field definitions are described in the following diagram. The important terms "left" and "right" are to be regarded respectively from the viewpoint of the connector side of the sensor.

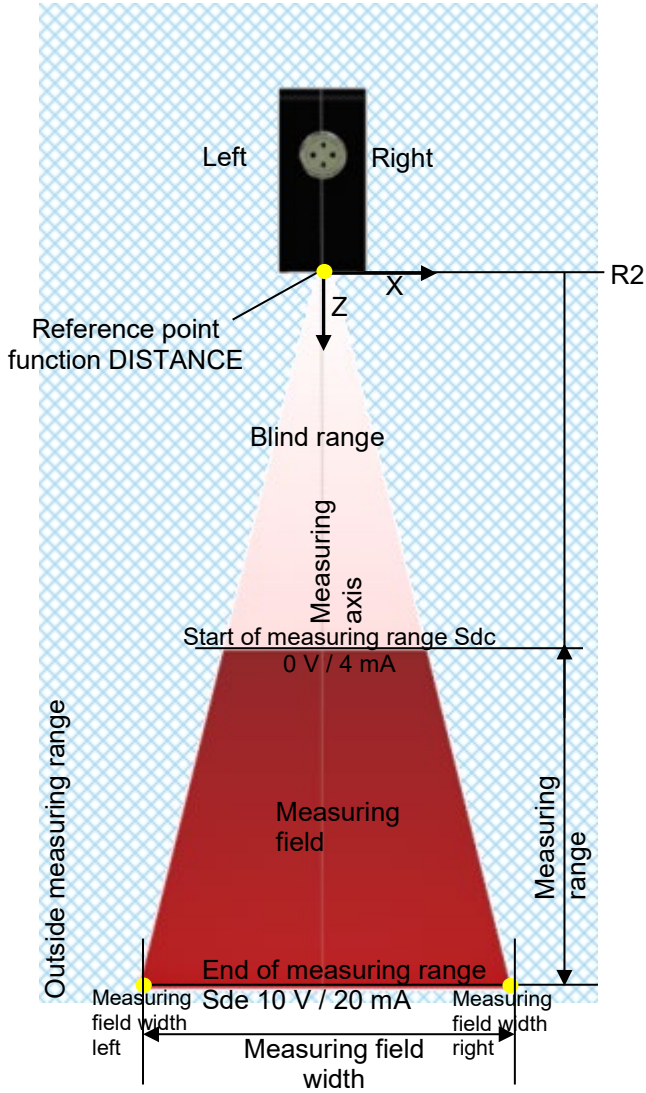

The sensor measures distances within the measuring field.  
The sensor level R2 is the reference for 0.

**NOTE**

 For further explanations, see section "Function and definition" -> "Interfaces and output" -> "Interfaces and output-> "Analog signal output".

### 4.3.1 Blind region

The region from sensor level R2 up to the start of measuring range Sdc is called the blind region, i.e. the sensor cannot detect any objects there.

Objects in this area can cause incorrect measuring values.

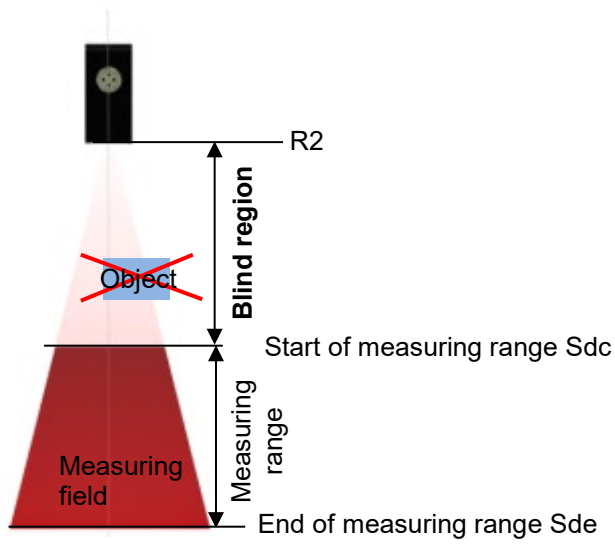

#### 4.4 Mounting:

The sensor is mounted at a right angle (90°) to the reference surface or the object (when there is no reference surface). A reference level and the object must be inside the measuring field (see definition of measuring field).

##### On reference level

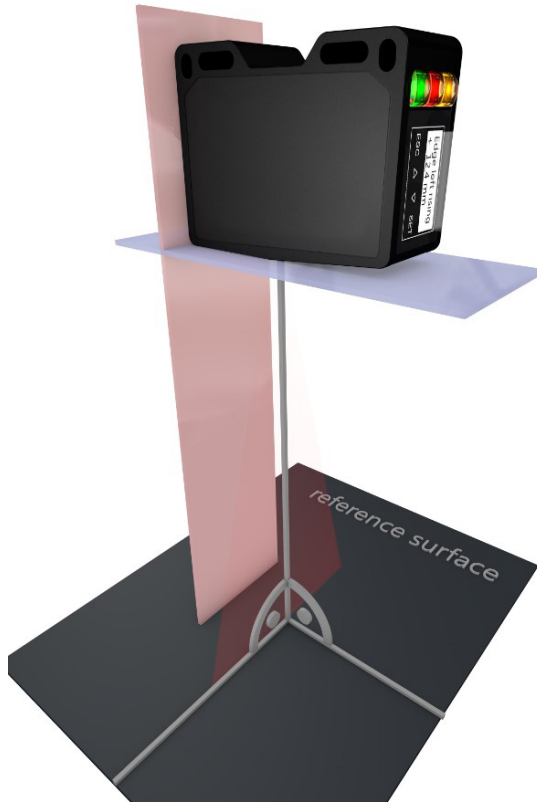

##### On object

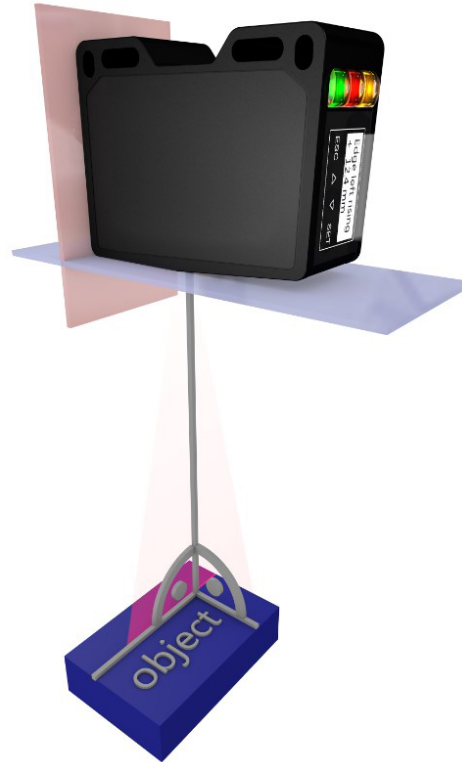

## 4.5 Installation accessories

To ensure optimal mounting, various mounting brackets are available as an accessory. These brackets fit the mounting holes of the sensor exactly. The sensor can be shifted and adjusted inside the mounting hole.

### 4.5.1 Mounting kit for PT74 series

With the mounting bracket AP000043 and the ball-head module AY000143, the sensor can be mounted quickly and easily in any orientation.



## 5 Configuration

### 5.1 Overview of control elements

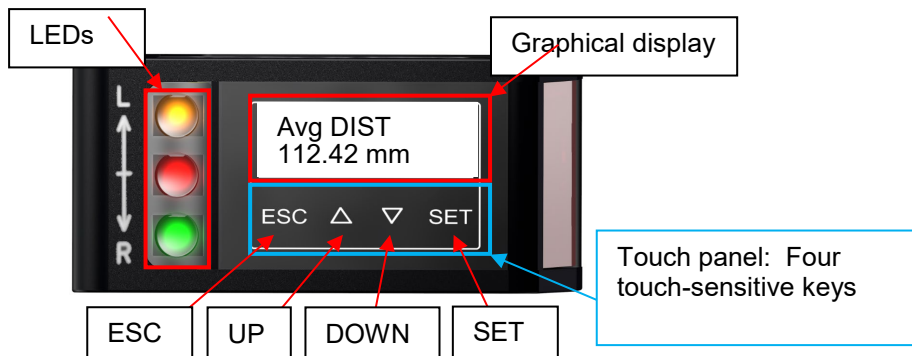

#### 5.1.1 Display modes

112.42 mm		<b>Run mode</b> The sensor is in run mode, the measuring value is displayed in large characters.
AVG DIST 112.42 mm		<b>Main menu</b> In the main menu the active mode is displayed at the top, and the measuring value is displayed at the bottom.
MEAS TYPE AVG DIST	█	<b>Scroll bar</b> The square on the right side indicates the position within the current menu. The next menu item can be accessed using the arrow keys.
MEAS TYPE AVG DIST	█	<b>Change value</b> If the function/mode at the top is displayed on a black background, the value of the bottom line can be adjusted using the UP/DOWN keys and saved with SET.
OK		<b>Process successful</b> The display background lights up green: Value successfully saved
FAILURE		<b>Error</b> The display background lights up red: Error during the save process or wrong value entered.
		<b>Setting mode</b> When the sensor is in setting mode the display background lights up blue.
⊙ 112.42 mm		<b>Keys locked</b> If this symbol is on the left side of the screen, the touch panel is locked for operation.

**5.1.2 Functions of the individual keys**

Key	Pressed briefly	Pressed >2 s.
ESC	Back	Jump to Run mode
UP	Up/increase value	
DOWN	Down/decrease value	
SET	OK	Save new value*

\*Only in the setting menu when the top line is displayed on a black background (change value)

**5.1.3 Locking the touch panel**

The keys on the control panel are locked when they are not pressed for 5 minutes. A key symbol appears, and the measuring value is displayed in large lettering.

When it is pressed, the following text appears:

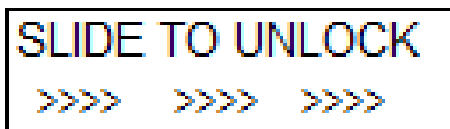

To re-enable the touch panel, it is required to quickly slide a finger over all four keys from left to right (slide over ESC, UP, DOWN, and SET).



**5.1.4 Further key functions**

Action	Reaction
Slide over all keys from left to right	<b>Unlock locked touch panel</b> Only if touch panel is locked
Slide over all keys from right to left	<b>Jump directly to run mode</b> Can be used from any menu

**5.1.5 LEDs on the sensor**

LED	Lights up	Flashes
Yellow	<b>Out1 activated</b> Switching output1 active	-
Red	<b>Out2 activated</b> No measuring object inside the measuring field. Alarm output active.	<b>Insufficient excess gain</b> Object close to signal gain (Not enough light). Performing setting OBJECT (Bright or Dark).
Green	<b>Supply voltage</b> Sensor ready for operation.	<b>Short circuit</b> Check connection on digital output 1 or 2.



## 5.2 Function tree

The menu that can be accessed via the touch panel is shown below.

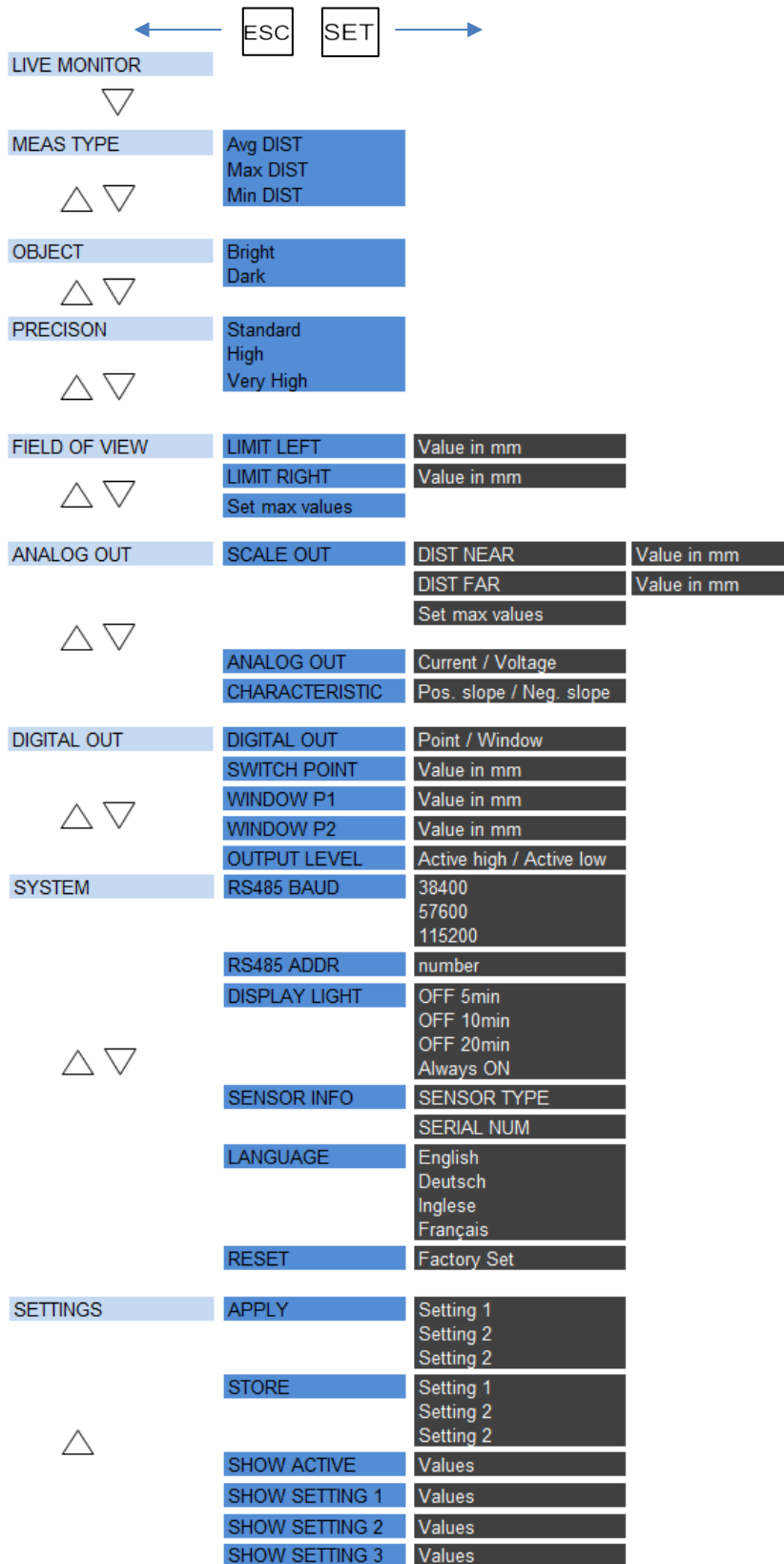

**5.3 LIVE MONITOR**

The installation conditions can be checked using LIVE MONITOR. The sensor outputs the angle and edge position to the object with the smallest distance to the sensor.

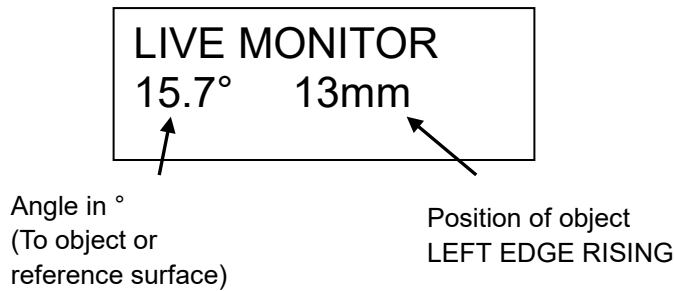

**LIVE MONITOR to reference surface**

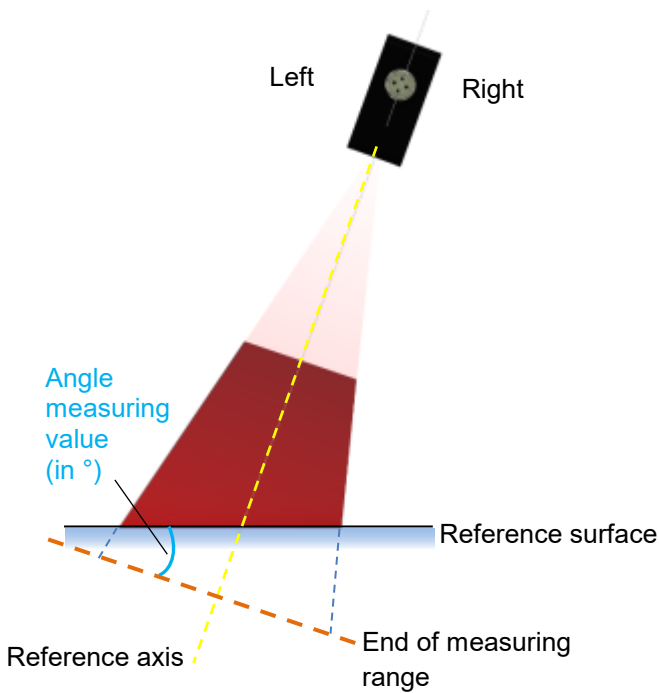

Display example:  
LIVE MONITOR  
30° ---- mm

**LIVE MONITOR to object**

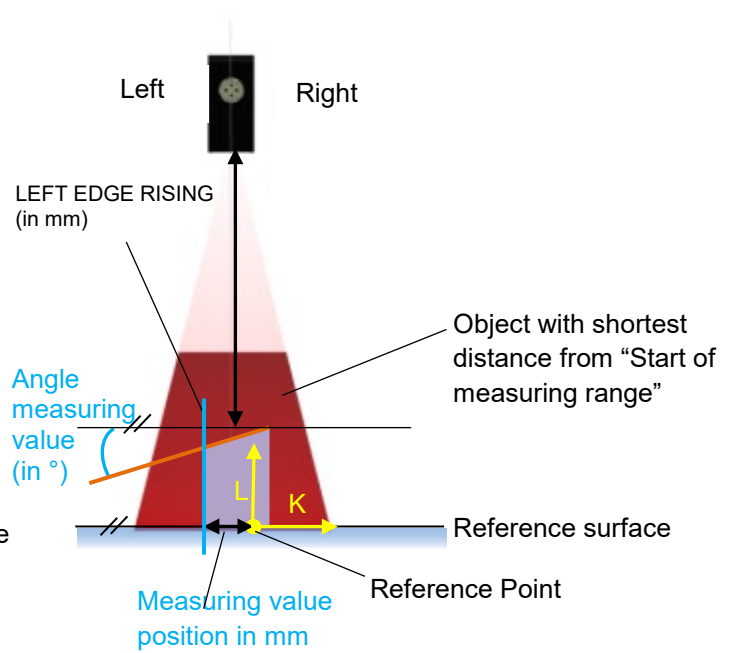

Display example:  
LIVE MONITOR  
15° 21.5mm

**NOTE**



To avoid measurement errors, the angle should be 0°

- “End of measuring range”<sup>1</sup> of the sensor represents the standard reference for angle measurement.
- Displayed for the edge position are always the values for the object or the reference surface with the smallest distance to “Start of measuring range”<sup>1</sup>.
- The requirements for the object with respect to the minimum width<sup>1</sup> and height<sup>1</sup> must be met.

**NOTE**

When several objects are in the measuring range, the object with the shortest distance from the start of measuring range is the reference object.

**Displaying the tilt angle**

For displaying the tilt angle of the sensor to the reference surface, in the measuring field must not be an object. The output will be ---- for EDGE LEFT RISING of the object.

**Finding the reference point without a teached reference surface**

Once an object is within the measuring range, the position of LEFT EDGE RISING and the angle of the surface of the object relative to the axis "End of measuring range"<sup>1</sup> are displayed.

When moving the object into the direction of the assumed reference point until LEFT EDGE RISING displays 0mm, the reference point is found.

---

<sup>1</sup> According to data sheet chapter 6.1

## 5.4 MEAS TYPE

The PT74 can output measured distances in various ways. The measuring value is calculated in mm with analog output.



**NOTE**

If the MEAS TYPE is changed, SCALE OUT, DIGITAL OUT and FIELD OF VIEW are reset to the default setting.

### Distance

#### 5.4.1 Avg DIST

Average distance to all measuring points.

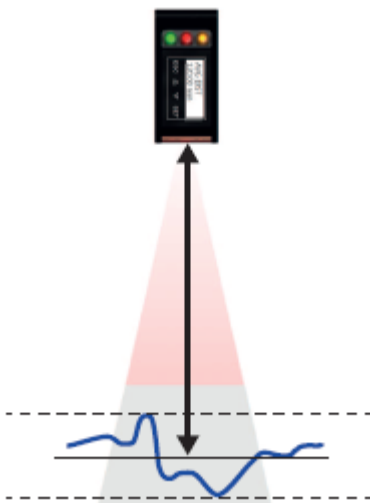

#### 5.4.2 Max DIST

Distance to the furthest measuring point.

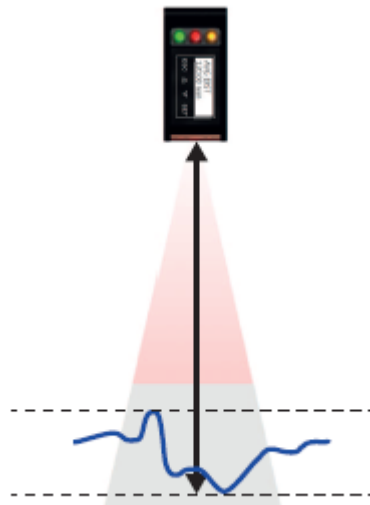

#### 5.4.3 Min DIST

Distance to the nearest measuring point.

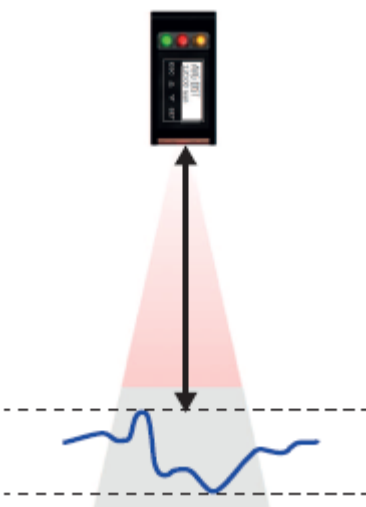

## 5.5 OBJECT

To improve sensitivity to dark objects, the exposure time can be increased. This also changes the measuring repetition time.

### 5.5.1 Object: Bright (Reflectivity > 18%, white-gray)

Exposure time (Pulse duration)	Short <sup>1</sup>
--------------------------------	--------------------

### 5.5.2 Object: Dark (Reflectivity 6...18%, dark gray-black)

Exposure time (Pulse duration)	Long <sup>1</sup>
--------------------------------	-------------------

## 5.6 PRECISION

By enabling filtering, the noise can be reduced and thereby the resolution can be increased.

Standard = normal resolution<sup>12</sup>  
 High = approx. twice the normal resolution<sup>12</sup>  
 Very high = approx. four times the normal resolution<sup>12</sup>

### 5.6.1 Influences of the filter PRECISION

The higher precision is set, the more measuring speed is reduced (response and the release time are increased). The measuring frequency is not affected by using this filter. PRECISION utilizes a moving median and a moving average filter.

#### Moving Median

The median of a finite list of numbers can be found by arranging all the observations from lowest value to highest value and picking the middle one (e.g., the median of {3, 3, 5, 9, 11} is 5). The number of samples stored in the array is called "Sample size" (e.g. {3, 3, 5, 9, 11} = 5 values). When a new sample is added the oldest sample is removed (Moving filter). A sudden change of the measured values will only effect the output after more than half of the samples stored resemble the new value (e.g. sample size=5 -> 3 samples until output is effected).

<sup>1</sup> According to data sheet chapter 6.1

<sup>2</sup> Dependent upon object to be measured

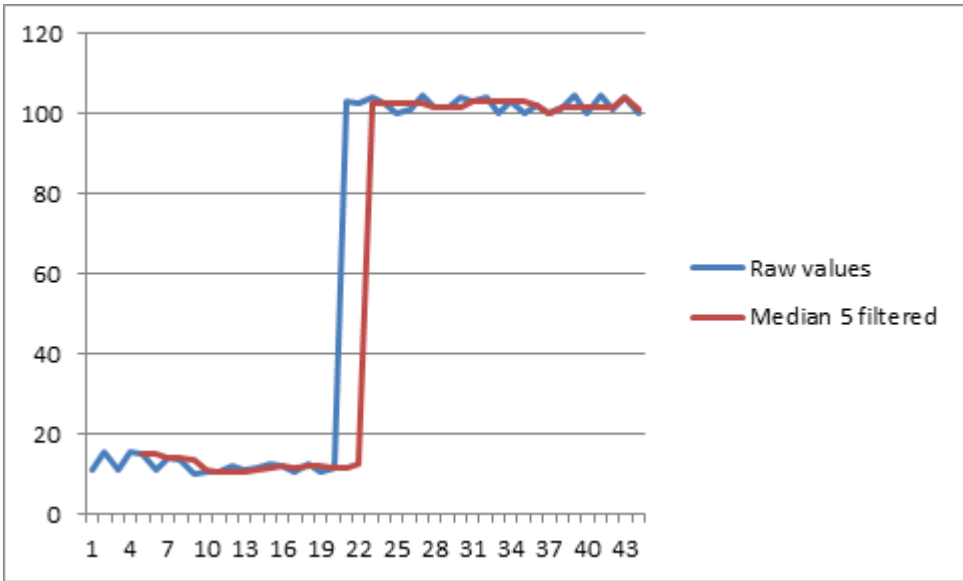

The diagram shows the effects of the median (sample size 5). The filter is used to suppress errors. The output changes after a defined number of samples (sample size/2). The measurement frequency is not affected by this filter, but rather the response time.

**Moving average**

The output of the moving average filter is the average of all values found in the array with the defined sample size. When a new sample is added, the oldest sample is removed (Moving filter).

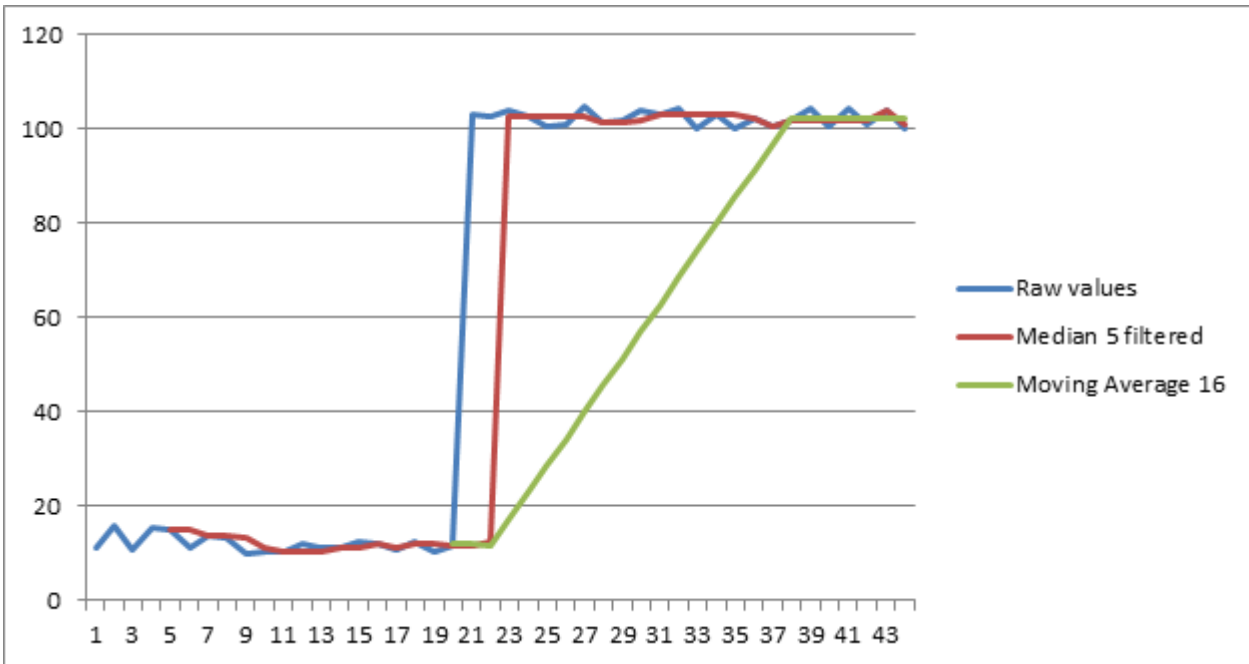

As visible in the diagram, the moving average softens the output. In contrast to the median filter, values at the output can be values that have never been measured. The measurement frequency is not affected by this filter, but rather the response time.

Number of samples until the correct value will be output:

- In PRECISION mode HIGH, the distance has to be stable for 4 + 16 samples for the output to show the current value.
- In precision mode very high, the distance has to be stable for 8 + 128 samples for the output to show the current value.

**Example**

Calculation of the response time with measuring frequency 500 Hz, PRECISION = High

$$1 / 500 \text{ Hz} = \mathbf{0.002 \text{ s}}$$

$$\text{Median} = 7 / 2 \text{ (Formula: Samples / 2)} = \mathbf{4}$$

$$\text{Average} = \mathbf{16}$$

$$\text{Response time} = \mathbf{0.002 * (4 + 16) = 0.04 \text{ s} = 40 \text{ ms}}$$

## 5.7 FIELD OF VIEW

The width of the measuring field can be limited with the FIELD OF VIEW function. All measuring values outside the set measuring field are ignored. This is particularly useful if, for example, the measuring field contains an unwanted object that should not be detected.

The measuring field is adapted by software so the width of the visible laser beam does not change.

### 5.7.1 Manual limitation of the measuring field

For full flexibility, every value in the measuring field can be individually adjusted. The modified measuring field need not be symmetrical. Even a single limit, e.g. LIMIT LEFT, can be restricted.

- LIMIT LEFT
- LIMIT RIGHT

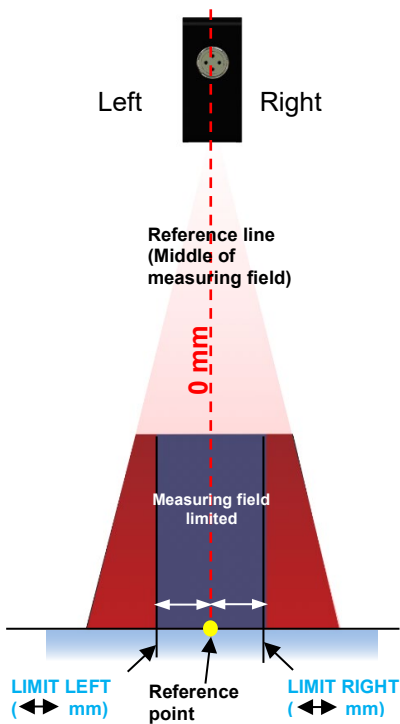

#### NOTE



The LIVE MONITOR mode can be used to find the reference point. This function displays the LEFT EDGE RISING of objects. Now an object is slowly pushed toward the presumed zero point. The zero point is reached when the value 0 mm is shown on the sensor display.

**5.7.2 LIMIT LEFT**

Limitation of the left side of the measuring field in mm, measured from the reference point.

**5.7.3 LIMIT RIGHT**

Limitation of the right side of the measuring field in mm, measured from the reference point.

**NOTE**

The measuring field width (Distance LIMIT LEFT to LIMIT RIGHT) must be at least 2 mm.

**5.7.4 FIELD OF VIEW**

"Set maximum values" resets all adjustments of the measuring field to the standard settings (maximum measuring field).

**5.8 ANALOG OUT**

**5.8.1 SCALE OUT**

In the factory setting, the analog output runs across the entire measuring range (start of measuring range Sdc - end of measuring range Sde) from 0...10V (voltage mode) or from 4...20mA (current mode).

The start and end of the measuring range can be reset with SCALE OUT, reducing the measuring field and changing the calibration curve.

The smaller measuring field improves the measurement repetition time, i.e, the measuring frequency is increased.

\*The minimum window size (distance from end of the measuring range Sde - start of measuring range Sdc) must be greater than 5% of the "end of measuring range" value.

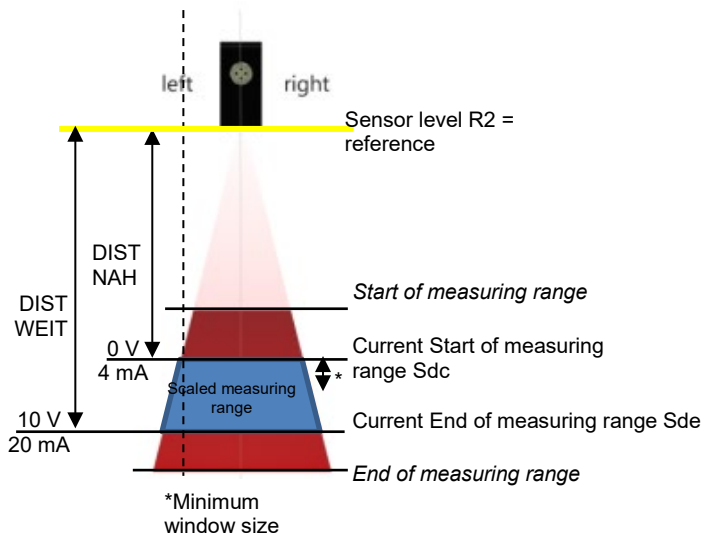

**5.8.1.1 DIST NEAR**

The value in mm at which the sensor should have the minimum analog output value of 0V or 4 mA is specified here.

DIST NEAR >= Start of measuring range  
 DIST NEAR <= End of measuring range – minimum window size\*

**5.8.1.2 DIST FAR**

The value in mm at which the sensor should have the maximum analog output value of 10V or 20 mA is specified here.

DIST FAR <= End of measuring range  
 DIST FAR >= Start of measuring range + minimum window size\*

	<p><b>NOTE</b></p> <p>The measuring cycles can be shortened by reduction of the window size, i.e. this increases the measuring frequency, according to data sheet chapter 6.1.</p>
---	--

**5.8.1.3 SET MAX VALUES**

**Example: SCALE OUT with DISTANCE function**

The sensor should display 4 mA at a distance of 110 mm and 20 mA at a distance of 140 mm.

- Set Dist NEAR to 110 mm
- Set Dist FAR to 140 mm

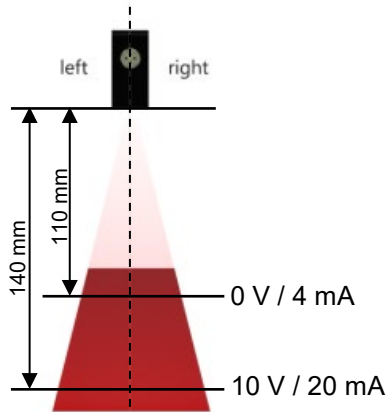

SCALE OUT is reset to the standard setting (maximum measuring field) with the "set max values" command.

**5.8.2 ANALOG OUT**

The analog output can be set from current to voltage.

**5.8.3 CHARACTERISTIC**

The analog characteristic curve can be inverted. With a positive output slope, the signal increases with an increasing measuring value. For the negative slope the output signal decreases with an increasing measuring value.

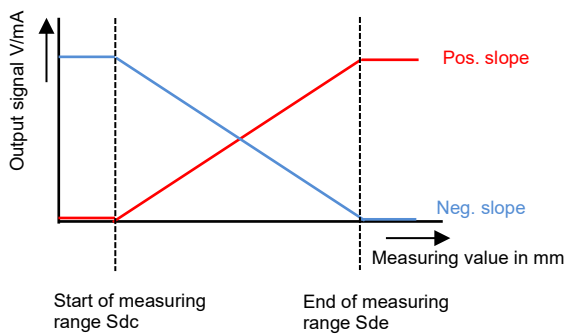

## 5.9 DIGITAL OUT

With Pin 4 (out), the user has a configurable switching output.

It can be defined as a single switching point (threshold) or a window. Pin 4 is activated when the value (point or window) is exceeded or not reached (active high or active low depending on the setting).

The switching points can only be placed inside the active, preset measuring field (note SCALE OUT). There is a hysteresis<sup>1</sup> for a reliable switching signal.

The window must be larger than 5% of the "end of current measuring range".

### Function Distance: Point

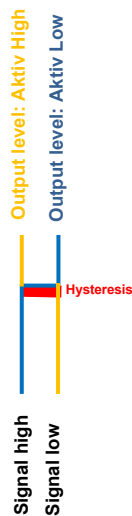
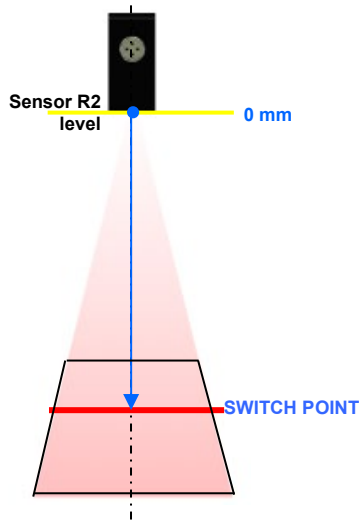

### Function Distance: Window

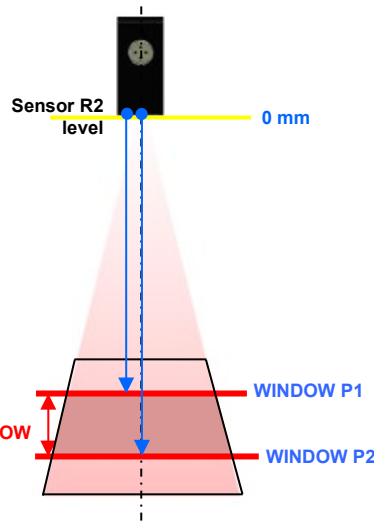

### 5.9.1 DIGITAL OUT

Whether Pin 4 is to be operated as a **threshold** (with a switch point) or as a **window** (window function) is defined here.

### 5.9.2 SWITCH POINT

The switch point is selected in mm using the arrow keys. The point must lie within the measuring range (between start of measuring range  $S_{dc}^1$  and end of measuring range  $S_{de}^1 - 2x$  hysteresis<sup>1</sup>).

<sup>1</sup> According to data sheet chapter 6.1

### 5.9.3 WINDOW P1

Window point 1 (for the WINDOW mode) is selected in mm using the arrow keys. The point must lie within the measuring range (greater than start of measuring range  $S_{dc}^1 + 2x$  hysteresis<sup>1</sup>).

### 5.9.4 WINDOW P2

Window point 2 (for the WINDOW mode) is selected in mm using the arrow keys. The point must lie within the measuring range (less than end of measuring range  $S_{de}^1 - 2x$  hysteresis<sup>1</sup>).

### 5.9.5 LEVEL

The output level can be inverted with **active high** or **active low** here.

#### NOTE

If MEAS TYPE is changed, the switching output settings are discarded. The factory settings are restored for DIGITAL OUT = End of measuring range  $S_{de}^1$ .

---

<sup>1</sup> According to data sheet chapter 6.1

## 5.10 SYSTEM

### 5.10.1 ANALOG OUT

The analog output can be reset to voltage or current, depending on purpose.

See the Section "Interfaces and output --> Analog signal output".

- Current
- Voltage

### 5.10.2 DISPLAY LIGHT

The display background illumination automatically switches off after the set time or remains switched on. The countdown begins as soon as the keys for an operation are locked (key symbol).

- OFF 5 min.
- OFF 10min.
- OFF 20min.
- Always ON

### 5.10.3 SENSOR INFO

The sensor type and serial number are displayed here to enable clear identification of the sensor.

- SENSOR TYPE
- SERIAL NUMBER

### 5.10.4 LANGUAGE

Language selection:

- English
- Deutsch
- Italiano
- Français

### 5.10.5 RESET

This resets all settings in sensor parameters to the factory settings.

MEAS TYPE	= Avg DIST
OBJECT	= Bright
PRECISION	= Standard
SCALE OUT	= Max. values
FIELD OF VIEW	= Max. values
DIGITAL OUT	= Threshold (end of measuring range Sde, active high)
ANALOG OUT	= Current
DISPLAY LIGHT	= OFF after 5min.
LANGUAGE	= English

#### NOTE



With "Reset", the current configuration in the sensor is overwritten. However, all stored settings are deleted from the sensor memory. The factory settings will be restored.

## 5.11 SETTING

The settings entered in the sensor can be applied, stored or displayed here.

### 5.11.1 APPLY

The settings saved under SAVE can be activated here.

- Setting 1
- Setting 2
- Setting 3

### 5.11.2 STORE

The settings entered in the sensor can be stored here.

Three storage spaces are available.

- Setting 1
- Setting 2
- Setting 3

### 5.11.3 SHOW

SHOW displays the setting values.

SHOW ACTIVE

Displays the active settings.

SHOW SETTING 1-3

Displays the settings stored in storage spaces 1-3

The values are displayed successively; it is possible to jump to the next value using DOWN.



MEAS TYPE  
OBJECT  
PRECISION  
SCALE OUT- Dist NEAR  
SCALE OUT- Dist FAR  
LIMIT LEFT  
LIMIT RIGHT  
SWITCH POINT  
WINDOW P1  
(WINDOW P2)  
OUTPUT LEVEL  
ANALOG OUT

## 6 Function and definition

### 6.1 Sensors data sheet

General data	PT740020	PT740021
Function	Distance	Distance
Function: FIELD OF VIEW	Yes	Yes
Measuring range (distance)	100...150 mm	100...500 mm
Start of measuring range Sdc	100	100
End of measuring range Sde	150	500
Measuring range (width)	48...72 mm	13 ...66 mm
Measuring field width right @ Sde	+36 mm	+33 mm
Measuring field width left @ Sde	-36 mm	-33 mm
Blind region	0...100 mm	0...100 mm
Measuring frequency – OBJECT bright (approx. 90% Refl.) – OBJECT dark (approx. 6% Refl.)	244...570 Hz <sup>14</sup> 192...342 Hz <sup>14</sup>	440...1540 Hz <sup>142</sup> 340...770 Hz <sup>142</sup>
Response time – OBJECT bright (approx. 90% Refl.) – OBJECT dark (approx. 6% Refl.)	3.5...8.2 ms <sup>14</sup> 5.8...10.4 ms <sup>14</sup>	1.3...4.5 ms <sup>142</sup> 2.6...5.8 ms <sup>142</sup>
Resolution AVG DIST (max. measuring field width)	8...16 μm <sup>345</sup> (Without filter) 4...8 μm <sup>3456</sup> (With filter Precision high) 2...4 μm <sup>3456</sup> (With filter Precision very high)	15...55 μm <sup>345</sup> (Without filter) 8...28 μm <sup>3456</sup> (With filter Precision high) 4...25 μm <sup>3456</sup> (With filter Precision very high)
Resolution MIN / MAX DIST	23...48 μm <sup>34</sup> (Without filter) 12...24 μm <sup>346</sup> (With filter Precision high) 6...12 μm <sup>346</sup> (With filter Precision very high)	70...150 μm <sup>34</sup> (Without filter) 45...75 μm <sup>346</sup> (With filter Precision high) 25...45 μm <sup>346</sup> (With filter Precision very high)
Repeatability AVG DIST (max. measuring field width)	8 μm <sup>345</sup> (Without filter) 4 μm <sup>3456</sup> (With filter Precision high) 2 μm <sup>3456</sup> (With filter Precision very high)	10...40 μm <sup>345</sup> (Without filter) 5...25 μm <sup>3456</sup> (With filter Precision high) 4...20 μm <sup>3456</sup> (With filter Precision very high)
Repeatability MIN / MAX DIST	16 μm <sup>34</sup> (Without filter) 8 μm <sup>346</sup> (With filter Precision high) 4 μm <sup>346</sup> (With filter Precision very high)	30...90 μm <sup>34</sup> (Without filter) 20...70 μm <sup>346</sup> (With filter Precision high) 15...60 μm <sup>346</sup> (With filter Precision very high)
Linearity error	± 20 μm <sup>3457</sup>	± 100 μm <sup>3458</sup>
Temperature drift	± 0.04% Sde/K <sup>345</sup>	± 0.04% Sde/K <sup>345</sup>
PRECISION filter values:	Median      Average	Median      Average
Standard	Off	Off
High	Off      3	Off      3
Very High	16      3	16      3
Smallest detectable object	0.7...1.1 mm	1...5 mm
Laser class	1	2
Max. reference surface unevenness (rms)	0.25 mm	1 mm
Min. reference surface length	24 mm	12 mm

<sup>1</sup> Measuring rate depends on the measuring field (distance). Min value: Maximum measuring field; Max. Value: 20% of the measurement field

<sup>2</sup> Measuring rate depends on the measuring field (width)

<sup>3</sup> Measurement with ipf standardized measuring equipment and targets depending on measuring range (distance)

<sup>4</sup> Measurement on 90% remission (white)

<sup>5</sup> Measurement with measuring type average

<sup>6</sup> With active filtering

<sup>7</sup> Measuring range (distance) 100...112.5 mm

<sup>8</sup> Measuring range (distance) 100...200 mm

LIVE MONITOR:		
Minimum object height	4 mm	10 mm
Minimum object width	4 mm	12 mm
Digital output hysteresis	0.5% of Sd (switch point)	1% of Sd (switch point)
Power on indication	Green LED	Green LED
Output indicator	Yellow LED / red LED	Yellow LED / red LED
Light source	Red laser diode, pulsed	Red laser diode, pulsed
Setting	Touch display	Touch display

Electrical data	PT740020	PT740021
Voltage supply range +Vs	15 ... 28 VDC	15 ... 28 VDC
Max. supply current (without load)	120 mA	150 mA
Output circuit	Analog	Analog
Output signal	4 ... 20 mA / 0 ... 10 VDC (adjustable)	4 ... 20 mA / 0 ... 10 VDC (adjustable)
Switching output	Push-pull	Push-pull
Output function	Out 1 / alarm	Out 1 / alarm
Output current	< 100 mA	< 100 mA
Baud rate	38400 / 57600 / 115200	38400 / 57600 / 115200
Reverse polarity protection	Yes, Vs to GND	Yes, Vs to GND

Mechanical data	PT740020	PT740021
Width / Height / Length	26 / 74 / 55 mm	26 / 74 / 55 mm
Design	Rectangular, front view	Rectangular, front view
Housing material	Aluminum	Aluminum
Front (optics)	Glass	Glass
Connection method	Plug M12 8-pole	Plug M12 8-pole
Weight	130 g	130 g

Ambient conditions	PT740020	PT740021
Ambient light immunity	< 35 kLux	< 35 kLux
Operating temperature	-10 ... +50 ° C	-10 ... +50 ° C
Storage temperature	-25...+75 ° C	-25...+75 ° C
Protection class	IP 67	IP 67
Vibration resistance (sinusoidal)	<b>IEC 60068-2-6:2008</b> 7.5mm p-p for f = 2 - 8Hz 2g for f = 8 – 200Hz, or 4g for 200 – 500Hz	<b>IEC 60068-2-6:2008</b> 7.5mm p-p for f = 2 - 8Hz 2g for f = 8 – 200Hz, or 4g for 200 – 500Hz
Resonance test	<b>IEC 60068-2-6:2008</b> 1.5mm p-p for f = 10 - 57Hz , 10 cycles for each axis 10g for f = 58 -2,000Hz, 10 cycles for each axis	<b>IEC 60068-2-6:2008</b> 1.5mm p-p for f = 10 - 57Hz , 10 cycles for each axis 10g for f = 58 -2,000Hz, 10 cycles for each axis
Vibration resistance (random)	<b>IEC 60068-2-64:2008</b> Spectrum: 0.1 g <sup>2</sup> /Hz for 20 – 1,000Hz, 30 minutes / axis (>10g RMS)	<b>IEC 60068-2-64:2008</b> Spectrum: 0.1 g <sup>2</sup> /Hz for 20 – 1,000Hz, 30 minutes / axis (>10g RMS)
Shock resistance	<b>IEC 60068-2-27:2009</b> 50g / 11ms or 100g / 6ms, 10 shocks in each axis and each direction 50g / 11ms or 100g / 6ms, 5,000 shocks in each axis and each direction	<b>IEC 60068-2-27:2009</b> 50g / 11ms or 100g / 6ms, 10 shocks in each axis and each direction 50g / 11ms or 100g / 6ms, 5,000 shocks in each axis and each direction
Impact resistance	<b>IEC 60068-2-27</b> 50g / 11ms or 100g / 6ms, 4,000 shocks in each axis and each direction	<b>IEC 60068-2-27</b> 50g / 11ms or 100g / 6ms, 4,000 shocks in each axis and each direction

Optical Properties	PT740020	PT740021
Light source	AlGaInP-Laser Diode	InGaAlP-Laser Diode
Wavelength	656 nm	660 nm
Operational mode	pulsed	pulsed
Pulse duration bright mode dark mode	0.6 ms 1.8 ms	0.15 ms 0.8 ms
Pulse period bright mode dark mode	>1.7 ms >2.9 ms	>0.65 ms >1.3 ms
Total emitted pulse power	3 mW	10 mW
Beam shape	elliptical (focused to laser line)	elliptical (focused to laser line)

Focus distance $d_f$	125 mm	350 mm
Beam size @ exit window perpendicular parallel	2.5 mm 7.5 mm	2.2 mm 5.8 mm
Beam size @ focus perpendicular parallel	< 0.1 mm $L = 73$ mm	< 0.4 mm $L = 65$ mm
Beam divergence perpendicular $\delta_{\perp}$ parallel $\delta_{\parallel}$	16.0 mrad 30.2°	4.8 mrad 9.4°
Nominal ocular hazard distance (NOHD) <sup>1</sup>	NA	1.5 m
Laser classification (per IEC 60825-1/2014)	Laser Class 1	Laser Class 2

### 6.1.1 Beam divergence

Perpendicular plane:

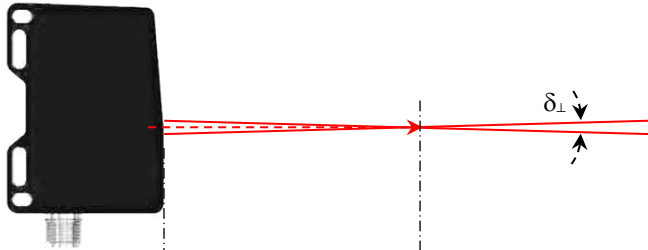

Parallel plane:

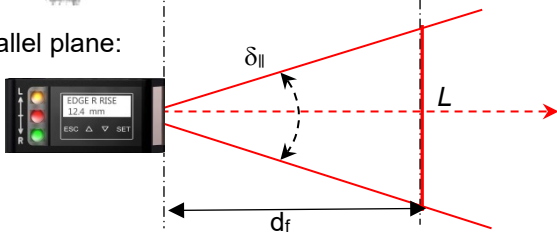

<sup>1</sup> Beyond the nominal ocular hazard distance, the accessible radiation exposure is below the limit of laser class 1

6.1.2 Dimensions

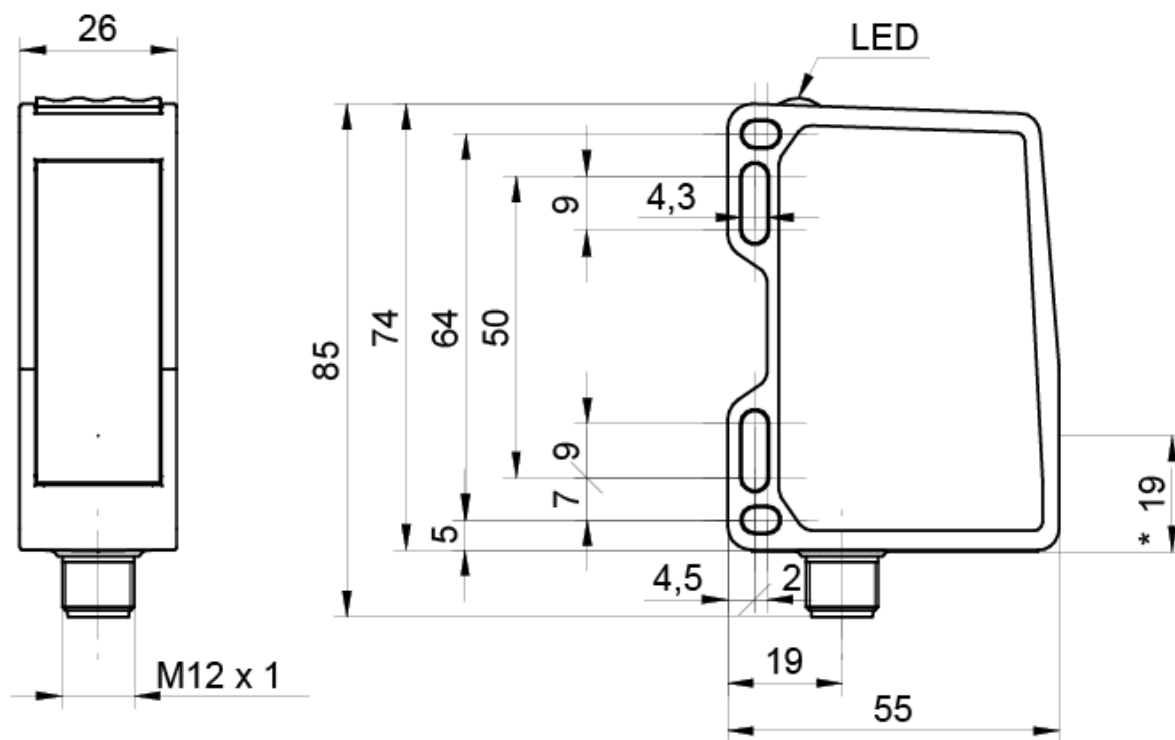

\* Optical axis

## 6.2 Functional principle

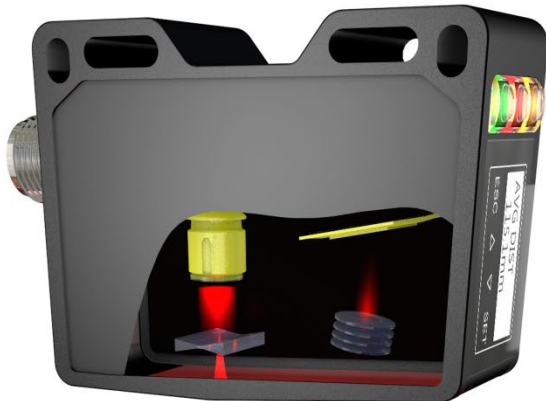

The sensor operates in accordance to the laser triangulation principle. By means of special optics, a laser beam is enlarged into a line and projected to the surface of the object to be measured. Using the multi-lens system, the reflected light from this laser line is projected onto a matrix. From this matrix image, a controller calculates the distance to every individual measuring point. The measuring value is calculated in accordance with the selected modus. Thanks to the factory calibration of the sensors, the output of the distance to the object is always in mm.

### 6.2.1 qTarget

The measuring field is aligned with the housing reference surfaces at the factory. The beam position in every sensor is in exactly the same spot, which makes planning and sensor replacement very easy.

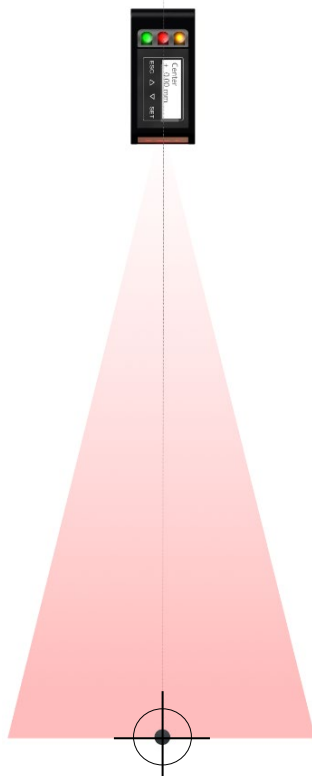

### 6.3 Measuring repetition time and response time

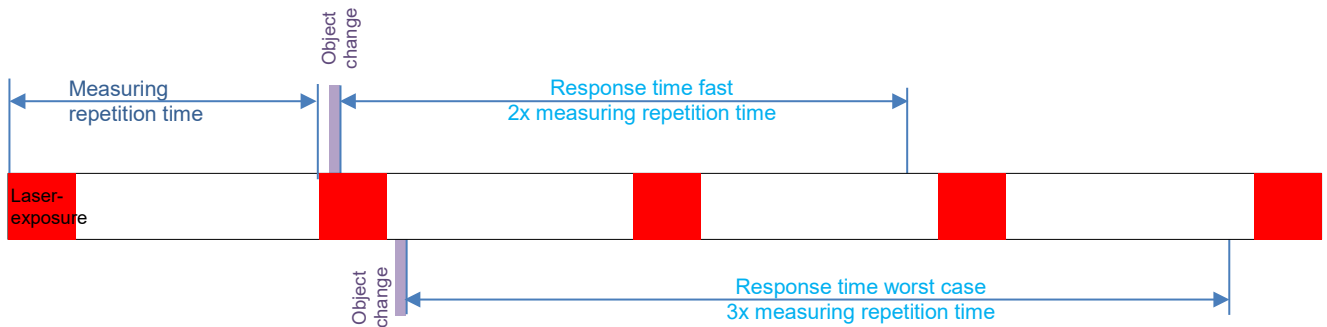

#### 6.3.1 Measuring repetition time

The measuring repetition time (specified in milliseconds) is the time between two exposure times.

Measuring repetition time = 1/Measuring frequency in Hz'

*Example:*

Measuring frequency = 100 Hz

1/100 Hz = 0.01 ms

Measuring repetition time = 0.01 ms

#### 6.3.2 Response time

Response time is called the time in which the sensor has output the new measured value after an object changed his position.

Typically it is about 2-3x measuring repetition time.

When the position of the object has changed during the exposure time, the response time is the fastest, ie about the 2x measuring repetition time.

At the worst case, if the object position has changed shortly after an exposure time, the response time is 3x measuring repetition time

#### 6.3.3 Response time when using Sync-In

If the Sync-In input is High, and then to start a measurement, is set to Low, the sensor starts with the exposure process.

This means that if the Sync-In is in use, the response time always is 2x the measuring repetition time.

## 6.4 Hysteresis

### 6.4.1 Definition of the hysteresis

The Hysteresis is the difference between switch-on and switch-off point. It is defined as a percentage of the sensing distance  $Sd$ . Without hysteresis  $H$ , objects could at the limit of the switching points lead to ceaseless on/off switching or bouncing.

### 6.4.2 Calculating the hysteresis

The absolute hysteresis  $H$  can be calculated by taking the Hysteresis  $h$  value from the data sheet.

$$H = Sd \times h$$

$$Sd = \text{Switching point}$$

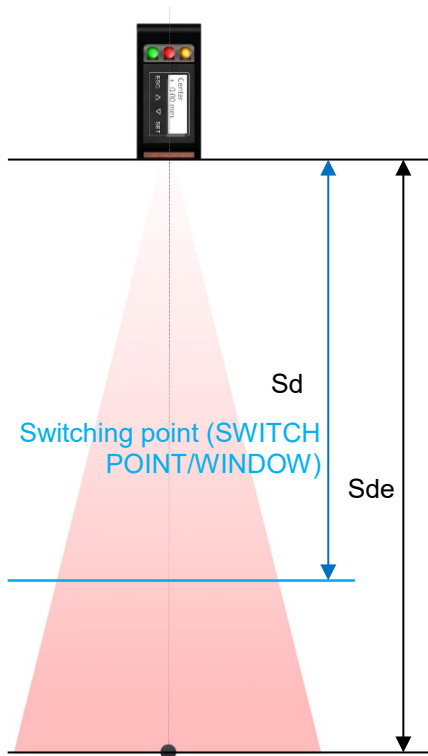

**6.4.3 Characteristics of the switching output at SWITCH POINT**

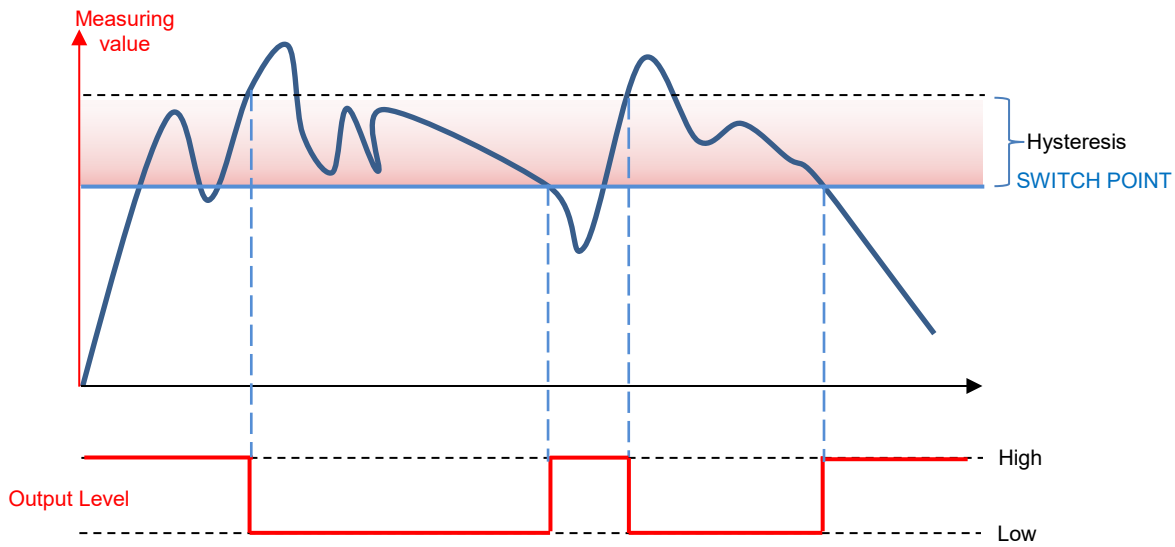

**6.4.4 Characteristics of WINDOW**

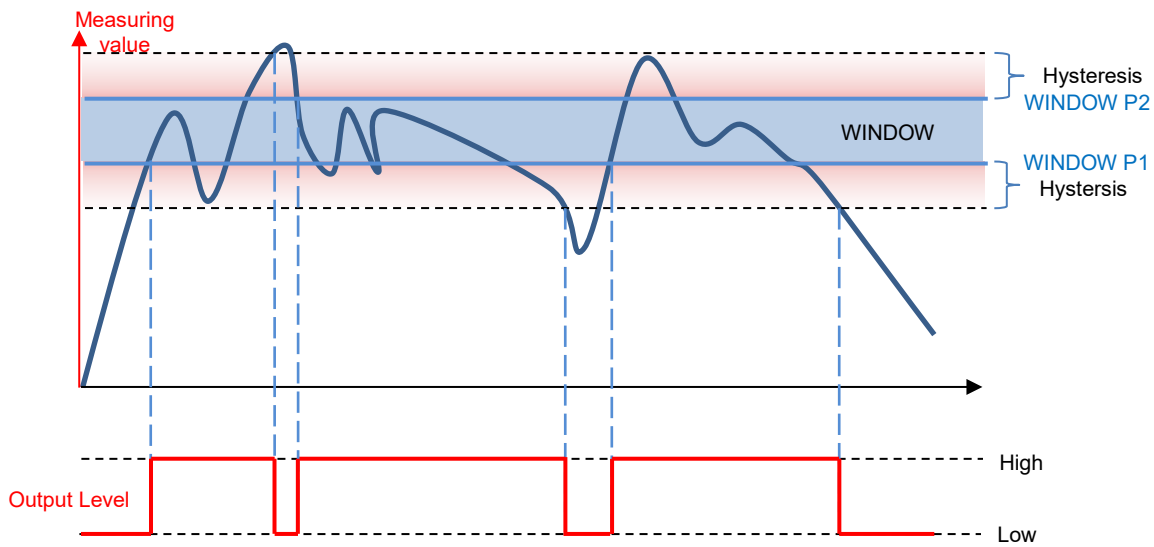

## 6.5 Object to be measured

### 6.5.1 Smallest detectable object

For an object to be reliably detected, it must conform to the minimum object width<sup>1</sup>. This minimum object width varies with the distance from the sensor.

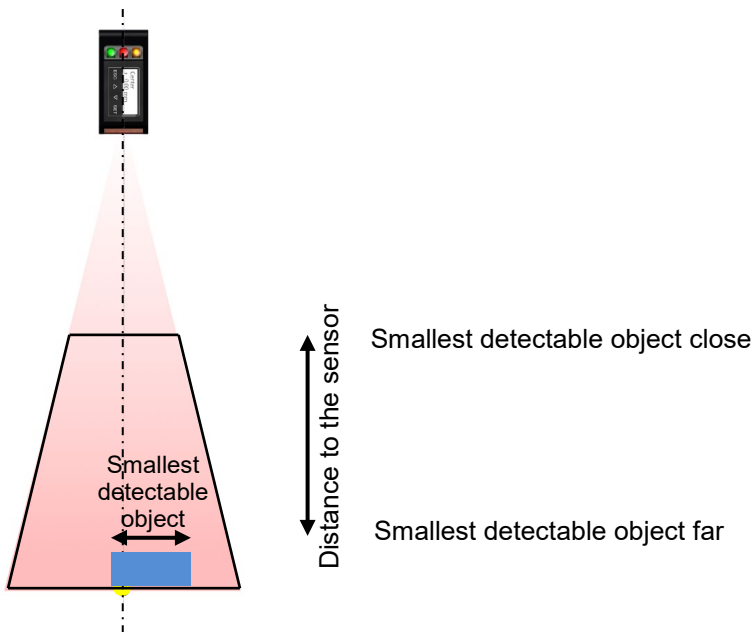

### 6.5.2 Reflectivity

Bright objects are generally easier to detect than dark objects, since they are more reflective. Reflectivity is the percentage relationship between incident and reflected light.

#### Definition of objects:

White object	Approx. 90% reflectivity
Black object	Approx. 6% reflectivity
Bright object	> 18% reflectivity
Dark object	6...18% reflectivity

### 6.5.3 Standard object

The technical data for sensors in the data sheet refers to measurements with an ipf standard object. This standard object is precisely defined in size, shape and color, making multiple measurements comparable.

#### Standard object definition:

- White ceramic (reflectivity approx. 90%)
- Smooth, flat surface
- Covers entire sensor measuring range

<sup>1</sup> According to data sheet chapter 6.1

## 6.6 Inputs and outputs

The PT740020/21 provides digital and analog outputs, as well as a sync-in.

- Analog output
- Synchronization
- Switching output
- Alarm output

### NOTE



When an object moves laterally out of the measuring field, the last valid output value is retained until an object is again present in the measuring range.

### 6.6.1 Analog signal output

#### Current or voltage output

The sensor has an analog output that can send a current or voltage signal through the same pin. The desired CURRENT or VOLTAGE output function can be activated in the SYSTEM --> ANALOG sensor settings.

#### Analog output with DISTANCE function

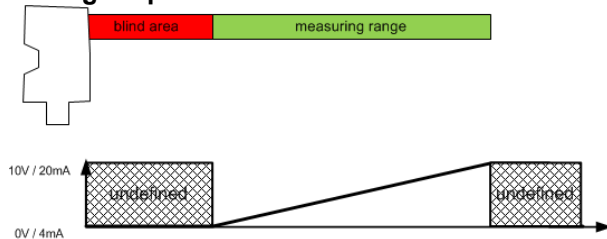

### NOTE



If the object leaves the measuring range, the analog output will hold the last valid condition.

**6.6.1.1 Formulas for analog signal conversion**

The measuring values can be converted from mm into the analog output signal and vice versa with the following formulas.

If the measuring range has been limited with SCALE OUT, the new settings for **Current Start of measuring range Sdc** and **Current End of measuring range Sde** must be used.

**DISTANCE function definitions**

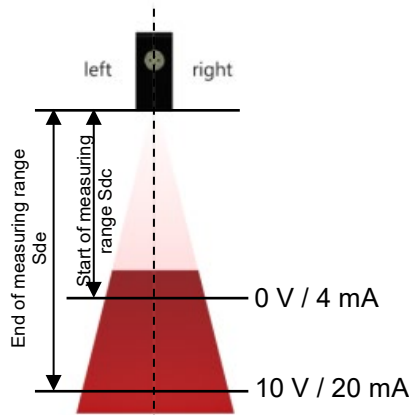

$$\text{Measuring value in V} = \frac{\text{Measuring value in mm} - Sdc}{Sde - Sdc} * 10V$$

$$\text{Measuring value in mA} = \frac{16 \text{ mA} * (\text{Measuring value in mm} - Sdc)}{Sde - Sdc} + 4 \text{ mA}$$

$$\text{Measuring value in mm} = \frac{\text{Measuring value in mA} * (Sde - Sdc) + (20 \text{ mA} * Sdc) - (4 \text{ mA} * Sde)}{16 \text{ mA}}$$

$$\text{Measuring value in mm} = \frac{\text{Measuring value in V} * (Sde - Sdc) + (10 \text{ V} * Sdc)}{10 \text{ V}}$$



**HINWEIS**

Sdc and Sde are always in mm.

**6.6.2 Sync-In / Trigger**

The measurement and signal output can be interrupted with the Sync-In input by connecting with high. As long as Sync-In stands at high, the sensor delays the next measurement (Hold) and reduces the power of the laser beam.

- The sensor checks the Sync-in before each measurement
- The previous measurement cycle will be always completed, even if the sync-in is High
- The sensor reduces the power of the laser beam during the waiting period (Hold)
- The outputs are held in the last valid state during Hold
- To come back to measuring mode, the Sync-In has to be set from High to Low
- The Sync-in must be at least 5µs at Low to come back to the measuring mode

Sync-In	Level	Measurement
Sync-In low	0...2.5 V	Run
Sync-In high	8 V...UB (operating voltage)	Hold

**Example: Mutual interference**

Only the laser beam of Sensor1 may be in the measuring field of Sensor1. The laser beam of Sensor2 must be outside the measuring field from Sensor1.

If it is not possible to prevent several sensors from affecting each other through appropriate installation, the sensors affecting each other can be operated asynchronously by the Sync-In cable. The superordinate control generates the signals for this.



**HINT**

Once the Sync-In is set to High (Hold), all output functions are frozen in their last state until the next measurement.

**Measuring if Sync-In low**

The sensor checks the level of the Sync-In each time before it sends out the laser pulse. If it is low, the sensor will immediately begin the next measurement.

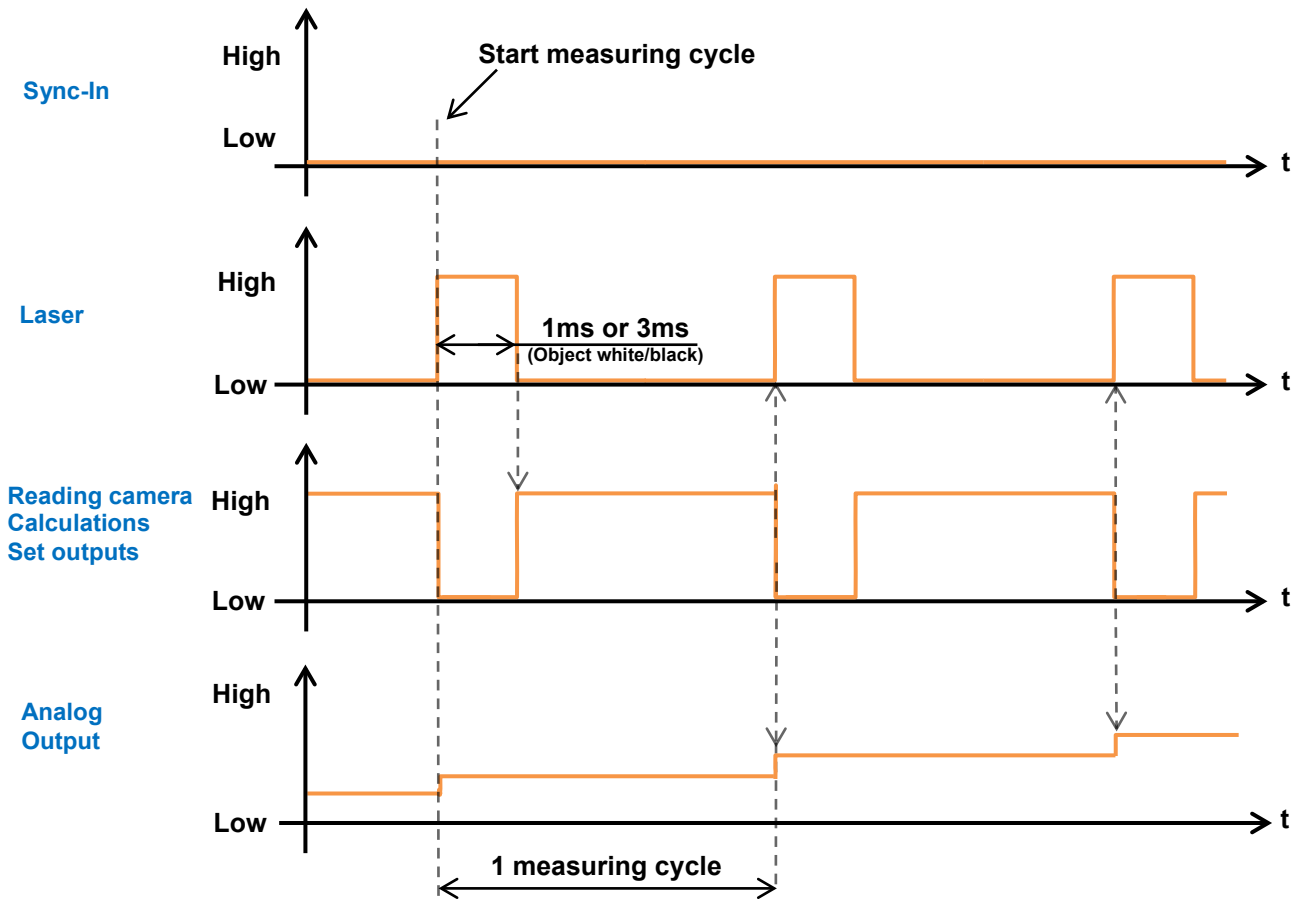

**Sync-In Low to High:**

If the Synchron-In level is High, the sensor completes the actual measurement, but do not start the next measurement. All outputs are held (Hold function).

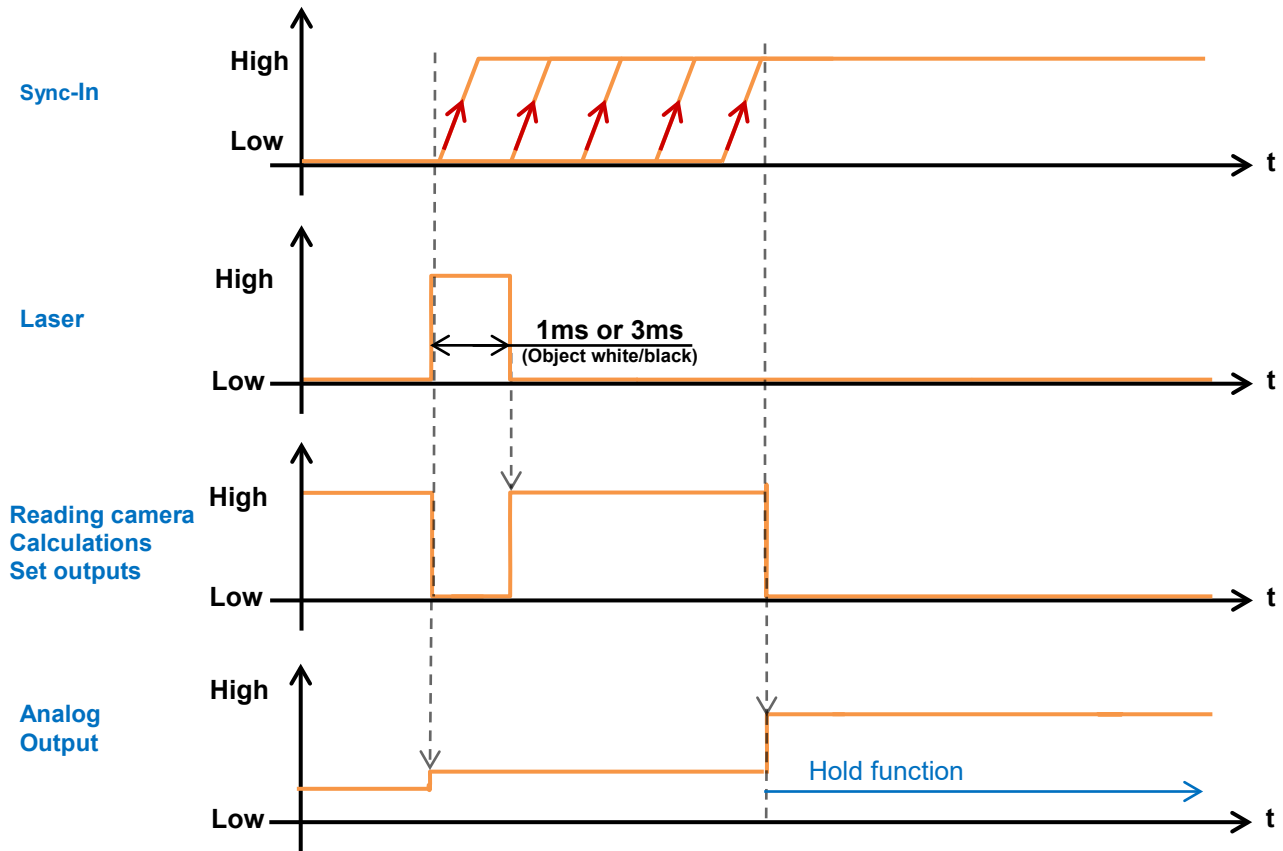

**Sync-In High to Low:**

Sync-In has to set from High to Low to bring the sensor back into the measuring mode. The Sync-In must be at least 5µs set to low level, so that the sensor starts to measure. For this first measuring cycle, the response time will be 5µs longer.

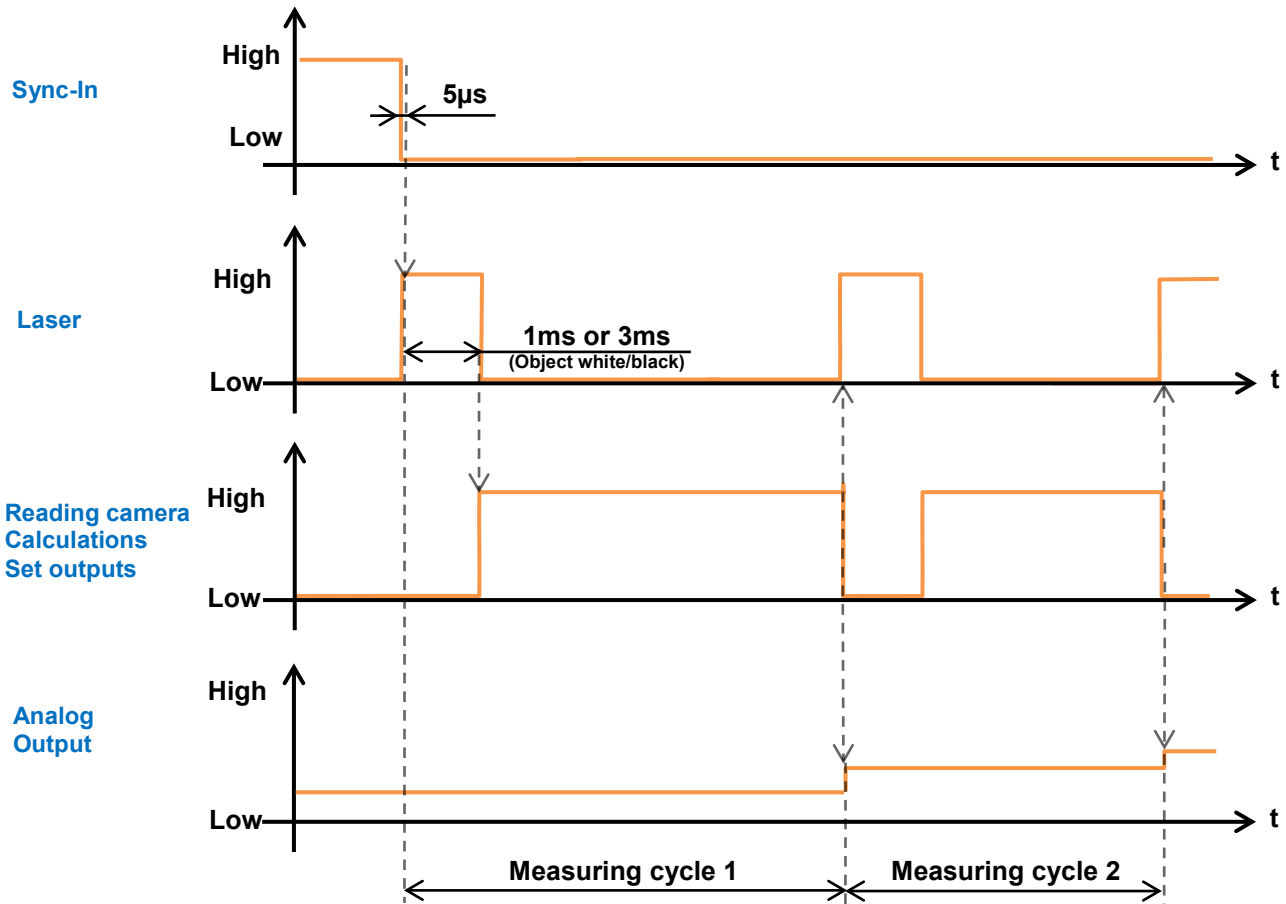

### 6.6.3 Switching output

The switching output can be set as a point or a window, see Section DIGITAL OUT.

The output is transmitted as a push-pool signal with active high or active low (inverted), depending on the setting.

### 6.6.4 Alarm output

The sensor evaluates the signal level (amount of reflected light) during every measurement cycle. If this level falls below a defined value (signal gain), the alarm output and red LED on the sensor are activated.

Reasons for a low signal level:

- Signal gain too small
- Incorrect mounting angle
- Insufficient light reflected from the object
- Object outside the measuring field

Signal level	Red LED	Alarm output out2
Signal gain reached	Off	Low
Signal gain not reached	Blinks (8 Hz)	Low
No object inside the measuring range	On	High

The alarm output cannot be adjusted and is triggered by the following situations:

- No object in the measuring field
- Insufficient signal gain (e.g. with soiling) or or incorrect OBJECT setting.

The alarm signal is output as a push-pull signal (active high).

#### NOTE



There is no excess gain hysteresis, which is why rapid switching between alarms can occur.

**6.6.5 Behavior of the outputs**

If no object is within the measuring range, the sensor will hold the last valid signal. The alarm output is high during this time.

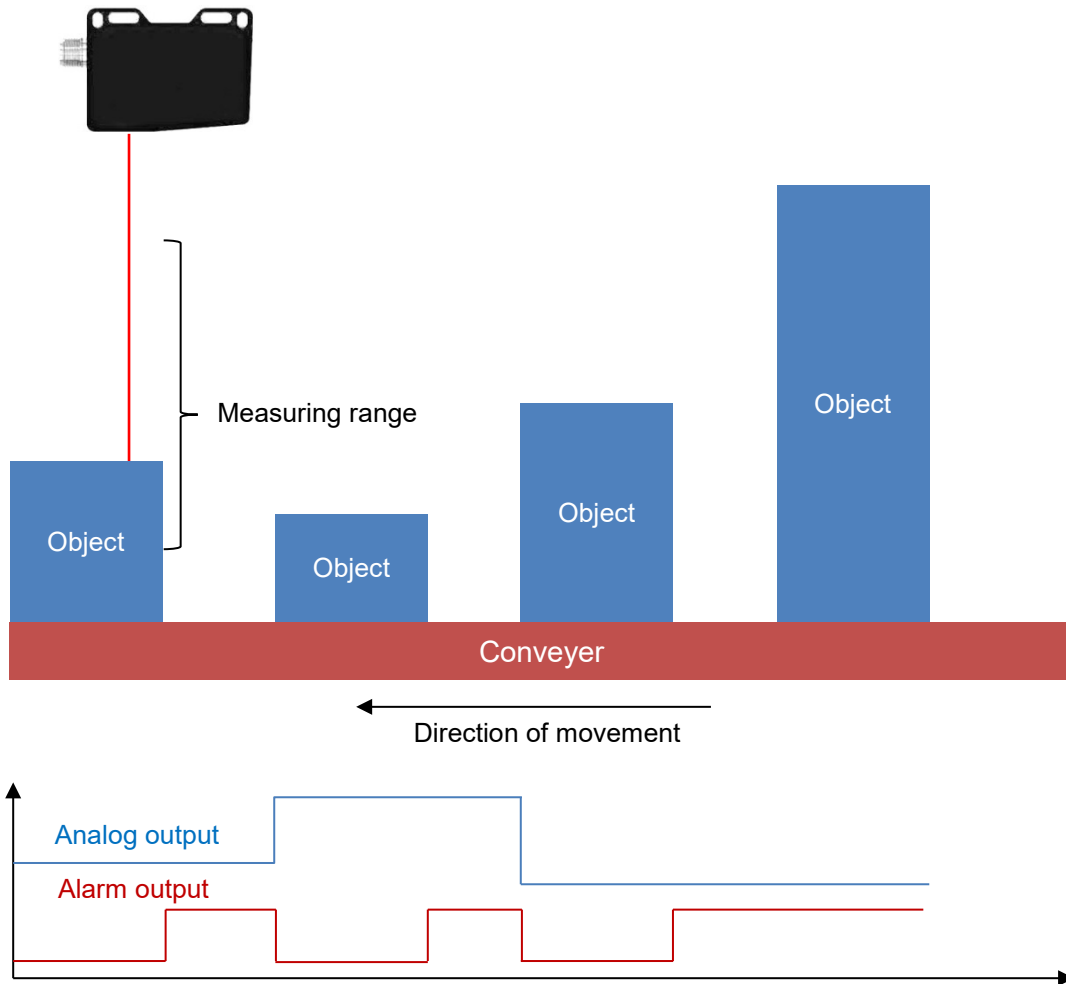

## 6.7 Touch panel

### 6.7.1 Function and design

The display consists of a monochrome 128 x 32 pixel LCD with RGB LED background illumination. The sensor can be configured using four capacitive touch operator interfaces.

### 6.7.2 Dimensioning

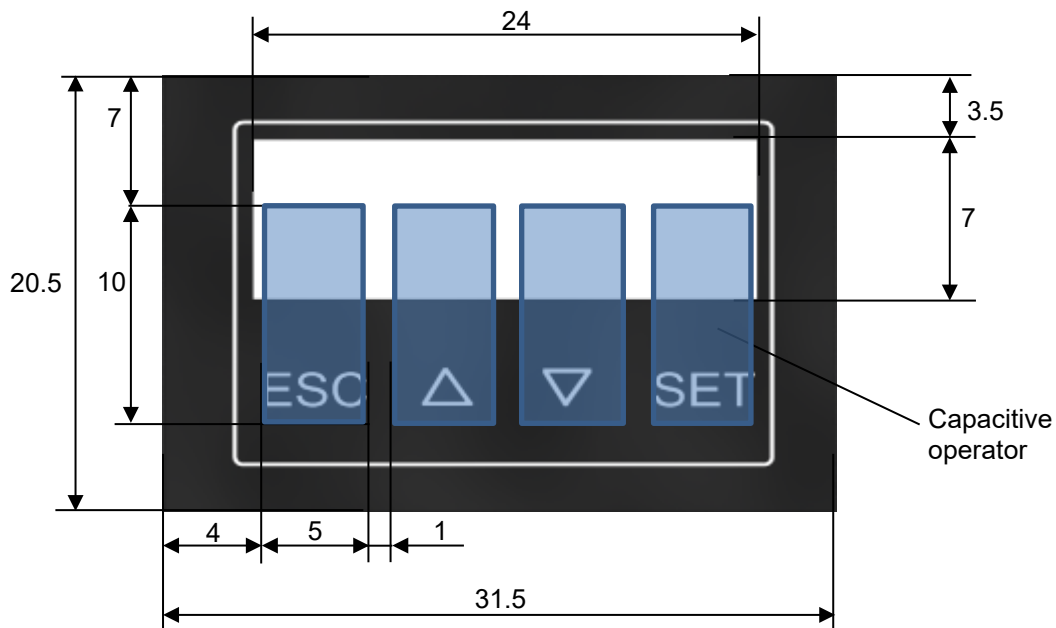

## 6.8 Memory

All changes made in the sensor are saved in nonvolatile (permanent) memory and are even retained after a power outage.

## 6.9 Standard deviation

The standard deviation is a term from the field of statistics or stochastics and is given in  $\sigma$  (sigma). With the standard deviation it is possible to determine how great the dispersion of values around a mean value is. Broadly speaking, the standard deviation is the average distance of all measured expressions of a characteristic from the mean value.

The standard deviation is only useful if you consider measured values which should actually be identical but which vary. For the sensor, this means that an even surface is observed vertically (or with an activated FLEX MOUNT). The standard deviation is then a measure for the unevenness of the surface. All measuring points within the preset field of view are taken into consideration.

### Remember

- The standard deviation is a measure for the dispersion of the height values of all measured profile points in mm.
- It can only be used on a plane that is either vertical with respect to the sensor or is parallel to the Flex Mount reference.
- The plane must cover the entire field of view in the X direction.

### 6.9.1 Example

This is a profile of 190 points on an even surface as recorded by the sensor before evaluation (height in mm). It is a typical line.

The red line represents the mean value, and the green lines each represent 1x standard deviation. The standard deviation indicates how level the measured line is.

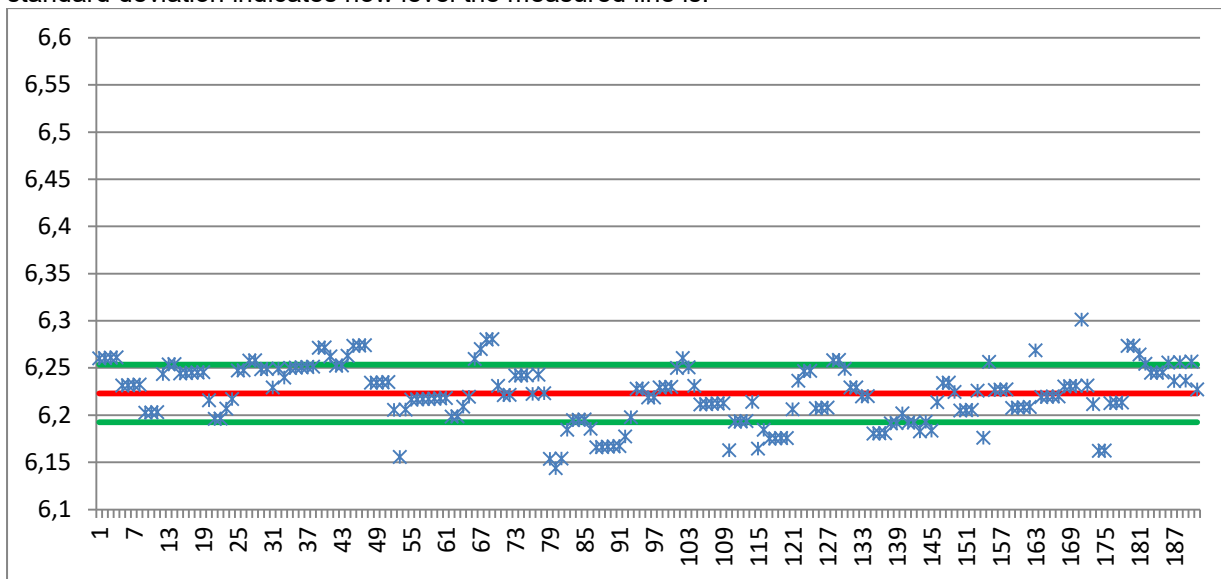

Standard deviation: 0.03 mm

Max-Min = 0.157mm

## 7 Safety instructions and maintenance

### 7.1 General safety instructions

#### Intended use

This product is a precision device and is used for object detection and the preparation and/or provision of measuring values as electrical quantities for a subsequent system. Unless this product is specially labeled, it may not be used for operation in potentially explosive environments.

#### Commissioning

Installation, mounting and adjustment of this product may be performed only by a qualified person.

#### Installation

For mounting, use only the mechanical mountings and mechanical mounting accessories intended for this product. Unused outputs must not be wired. In cable versions with unused cores, these cores must be insulated. Always comply with admissible cable bending radii. Prior to electrical connection of the product, the system must be disconnected from the power supply. In areas where shielded cables are mandatory, they must be used as protection against electromagnetic disturbances. If the customer makes plug connections to shielded cables, an EMC version of the connectors should be used, and the shield must be connected to the connector housing across a large area.

#### CAUTION

Use of controls or adjustments or performance of procedures other than those specified herein may result in hazardous light exposure.

### 7.2 Part identification

<p style="writing-mode: vertical-rl; transform: rotate(180deg);"><b>Explanatory and warning label</b></p>	<p style="text-align: center;"><b>Class 1: No risk to eyes or skin</b></p> <div style="border: 2px solid black; padding: 10px; text-align: center; margin: 10px auto; width: 80%;"> <p><b>CLASS 1 LASER PRODUCT</b></p> </div> <p>A Class 1 laser product is defined as safe in normal operations under reasonably foreseeable conditions, including long-term direct viewing of the beam, even when exposure occurs while using telescopic optics. However, direct viewing of a Class 1 laser product may still produce dazzling visual effects, particularly in low ambient light.</p>	<p style="text-align: center;"><b>Class 2: Do not stare into beam</b></p> <div style="display: flex; justify-content: space-around; align-items: center; margin: 10px auto;">  <div style="border: 2px solid black; padding: 5px; text-align: center; width: 150px;"> <p><b>LASER RADIATION DO NOT STARE INTO BEAM</b> Wavelength: 640...670nm  IEC 60825-1, Ed. 3, 2014 <b>CLASS 2 LASER PRODUCT</b></p> </div> </div> <p>Class 2 lasers emit radiation in the visible portion of the spectrum (400 nm to 700 nm). A short-term exposure (duration to 0.25 s) is harmless to the eye. Random short-term impacts (to 0.25 s) do not damage the eye, because the blink reflex can automatically adequately protect the eye against longer irradiation. Class 2 lasers may be used without any additional protection, if it is ensured that for an application no intentional look longer than 0.25 s is required, or (for example, by drug exposure) the blink reflex is suppressed.</p>
<p style="writing-mode: vertical-rl; transform: rotate(180deg);"><b>Certification label</b></p>	<p>FDA certification label</p>	
<p style="writing-mode: vertical-rl; transform: rotate(180deg);"><b>Identification label</b></p>	<p>The sensor identification part contains the following information:</p> <ul style="list-style-type: none"> <li>• Company Logo</li> <li>• Sensor brand name</li> <li>• Article description and article number</li> <li>• Production information</li> <li>• Serial number</li> </ul>	

### 7.3 Influence of ambient light

Ambient light from lamps, the sun, etc. in the view field of the sensor can lead to malfunctions or a reduction of accuracy and should be avoided as much as possible.

### 7.4 Front (optics)

In the event of broken front window, broken display panel or loose or detached laser optics the sensor must immediately be disconnected from the power supply and it must not be put back into operation until it has been repaired by an authorized person.

Non-compliance with these safety instructions may result in hazardous radiation exposure!

**ATTENTION!**

The use of a sensor with a broken front glass or dissolved or detached lens may result in hazardous radiation exposure.

### 7.5 Cleaning the sensors

The laser distance sensors do not require any maintenance, except that the front windows must be kept clean. Dust and fingerprints can impair sensor function. It is normally sufficient to wipe the windows with a clean (!), soft lens cleaning cloth. Alcohol or soapy water can be used in case of severe soiling.

The display and the keys must be kept free from dirt and moisture. Water and dirt on the keys can impair their function.

### 7.6 Disposal

This sensor contains electronic components. Components are to be disposed of according to the regulations prevailing in the respective country.

## 8 Error correction and tips

### 8.1 Examples of sensor setup

#### 8.1.1 Simple distance measurement to an object

1. Connection: In accordance with connection diagram
2. Installation: The sensor is installed so the object is inside the measuring range during the measuring procedure
3. Min DIST measurement type for output of minimum distance to the object

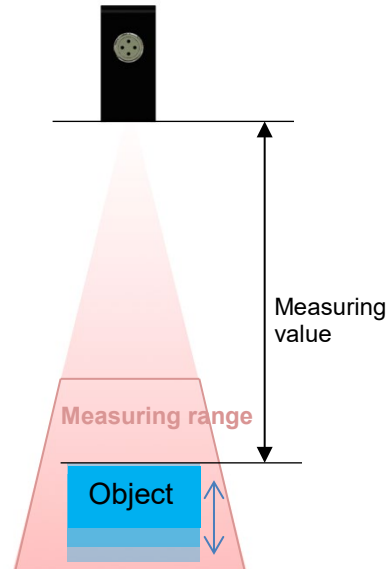

#### 8.1.2 Measurement of the average distance value of a dark object, digital signal at 130 mm distance

1. Connection: In accordance with connection diagram
2. Installation: The sensor is installed so the object is inside the measuring range during the measuring procedure.
3. Avg DIST measurement type for average value of distance to the object
4. OBJECT: Set dark
5. Set switching output DIGITAL OUT to 130 mm as the Point

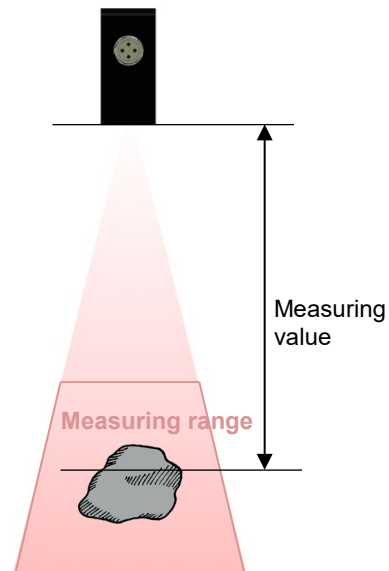

## 8.2 Error correction

Error	Error correction
No function	<ul style="list-style-type: none"> <li>• Check connection. Power supply 15...28 VDC between pin 2 (+Vs, brown) and pin 7 (GND, blue)</li> </ul>
Green LED flashes	<ul style="list-style-type: none"> <li>• Short circuit at the digital output. Check connection.</li> </ul>
Red LED lights up	<ul style="list-style-type: none"> <li>• Object outside measuring field (near, far or to the side)</li> <li>• Amplitude of the received signal is insufficient (e.g. in case of soiling)</li> </ul>
Touch panel cannot be operated	<ul style="list-style-type: none"> <li>• Touch panel locked. Re-enable panel for operation by sliding a finger over the 4 keys from left to right.</li> </ul>
Touch panel does not react	<ul style="list-style-type: none"> <li>• Clean panel. The panel is dirty or wet, which makes it harder to press the keys</li> </ul>
Sensor does not provide the expected measuring results	<ul style="list-style-type: none"> <li>• The object is not in the measuring range</li> <li>• Bright object, avoid direct reflexes from the transmitter to the receiver</li> </ul>
The sensor does not capture all objects within the measuring field	<ul style="list-style-type: none"> <li>• The red visible laser beam does not represent the maximum measuring field. If the object is at the edge of this beam it could be outside the measuring range</li> <li>• Move object. The object is outside the measuring field vertically or is in the blind region of the sensor</li> </ul>
Unreliable measuring value: The measuring value jumps back and forth	<ul style="list-style-type: none"> <li>• The object is not in the measuring range</li> <li>• Avoid bright object</li> <li>• Avoid very dark object</li> <li>• Too much ambient light</li> <li>• Check measuring mode setting (MEAS TYPE)</li> </ul>
Transmitting laser light is dim	Sync-In input is on High--> set to Low