

## VL150122

### CONNECTION TECHNOLOGY • LOGIC MODULES

Logic module, 10x41x26mm, OR, 2fold, 10-30V DC, sensor side M8 Female (socket) 3pin, control side M8 Male (connector) 3pin, IP67, Plastic



#### MECHANICAL FEATURES

Ambient temperature	-25 °C ... 70 °C
Degree of protection (IP)	IP67
Height	10 mm
Housing material	Plastic
Length	40.6 mm
Mounting method	Screw mounting
Rail mounting possible	-
Type of electrical connection, control side	Male (plug)
Type of electrical connection, sensor side	Female (socket)
Width	26 mm

#### ELECTRICAL FEATURES

Cascadable	-
Logic	OR
No-load current	0.1 mA
Number of inputs per logic unit	2
Number of logic units	1
Number of pins of connections, control side	3
Number of pins of connections, sensor side	3
Number of sensor connection positions	2
Operating voltage	10 V ... 30 V
Rated switching current	200 mA
Switching frequency	5000 Hz
Type of electrical connection, control side	M8
Type of electrical connection, sensor side	M8
Voltage type	DC
With LED display	+

#### Other

Packaging dimensions	100mm x 12.0mm x 120mm
Shipping weight	0.01kg
Tariff code	85365005

## Classification

ipf product group	800
eClass 8.0	27242216
eClass 9.0	27242216
eClass 9.1	27242216
ETIM-5.0	EC001417
ETIM-6.0	EC001417
ETIM-7.0	EC001417

## Connection

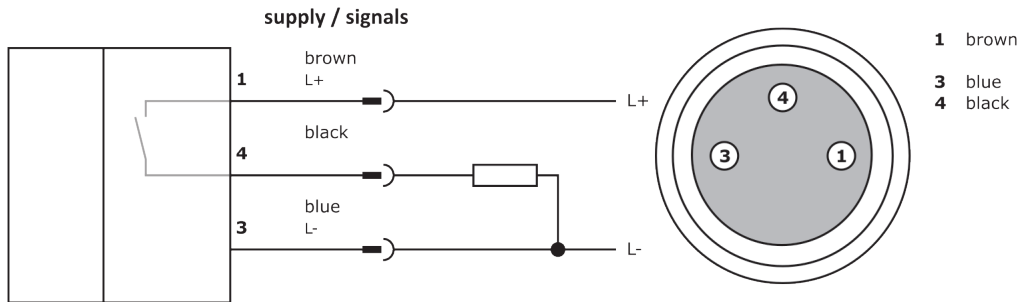

## Dimensional drawing

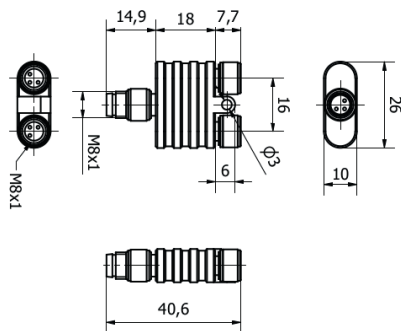

## Installation



Mounting / installation may only be carried out by a qualified electrician!

## Disposal



## Safety warnings

Before initial operation, please make sure to follow all safety instructions that may be provided in the product information. Never use these devices in applications where the safety of a person depends on their functionality. LED lighting systems can generate intensive UV radiation, which can damage your eyes in case of improper use. The manufacturer cannot be held responsible for damages that result from improper use or connection.