

Manual for devices with flow and temperature monitoring

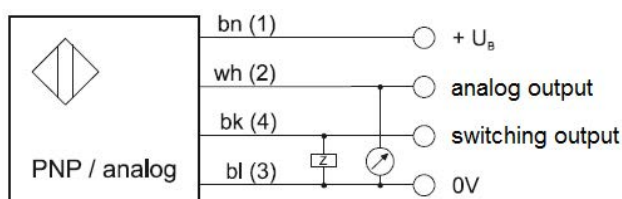

Technical Data	SS430020	SS430021	SS430022
operating voltage current consumption (w/o load)		24V DC \pm 10%	
switching output		pnp, no/nc programmable	
analog output		4 ... 20 mA	
load R_L		200 ... 500 Ω	
ambient temperature		0 ... 60°C	
medium temperature		-10 ... +90°C	
temperature gradient		400 K/min	
power-on time		6 ... 10s	
reaction time		1 ... 8s	
power-on delay time		0 ... 50s	
power-off delay time		0 ... 50s	
outside tube diameter D_a	\varnothing 10mm	\varnothing 15mm	\varnothing 18mm
span SW*	19mm	25mm	30mm
operating range	1 ... 10l/min	2 ... 20l/min	4 ... 40l/min
adjustment range	1.2 ... 10l/min	2.2 ... 20l/min	4.2 ... 40l/min
hysteresis S	0.2 ... 2l/min	0.2 ... 5l/min	0.2 ... 10l/min
temperature monitoring		-10 ... 90°C	
adjustment range S		-9 ... 90°C (if temperature selected)	
hysteresis S		1 ... 10°C (if temperature selected)	
medium		water / glycol (0, 5, 10, 15, 20, 25, 30%)	
pressure resistance		20bar	
display flow rate		LED 7-segment, 3-digit	
degree of protection		IP65 acc. EN 60529	
electrical connection		M12-connector, 4-pin	

Connection



bn=brown, wh=white, bk=black, bl=blue
terminal marking of cable socket in brackets

Dimensional drawing

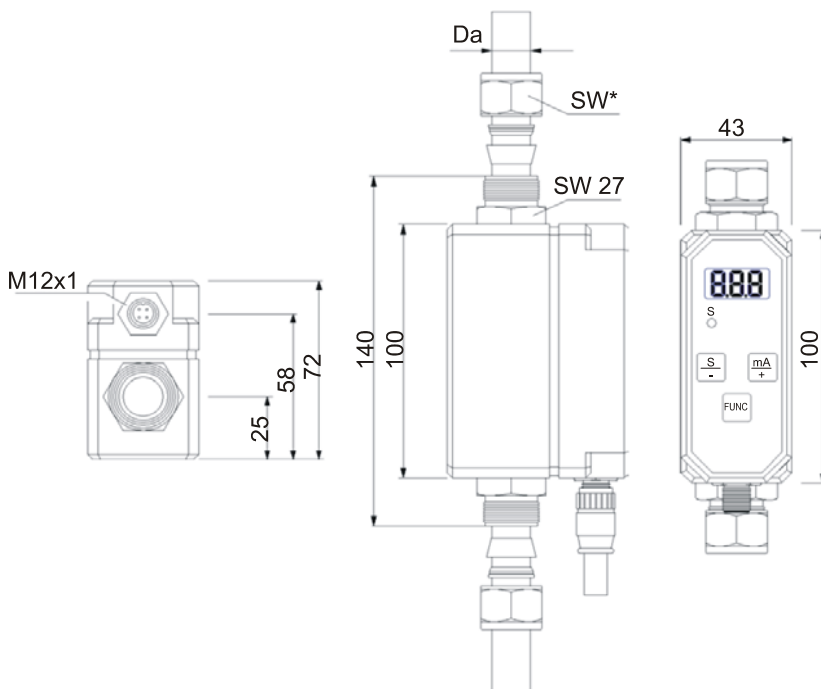

Installation

The inline flow sensors SS43 are built „in-line“ into a pipe line. The pipe may be connected directly via the cutting ring threaded connection or via a matching adapter. The adapters come as accessories for a transition from $\varnothing 10$ mm to G1/4 or $\varnothing 18$ mm to G1/2. In order to achieve the best accuracy, the sensor has to be installed in such a way that the electrical connection is opposite to the flow direction. The medium has to be free of air pockets and bubbles.

Mounting of the cutting ring threaded connection

If no pipe adapters are installed, a precision-grade pipe that meets the requirements of DIN 2391, must be used. The pipes must feature the following diameters and wall thicknesses:

- SS430020: $\varnothing 10 \times 1$ mm
- SS430021: $\varnothing 15 \times 1.5$ mm
- SS430022: $\varnothing 18 \times 1.5$ mm

1. Cut pipe to length at a right angle and remove burr.
2. Push couplin nut and clamp and cutting ring, as shown in the dimensional drawing, onto the pipe and insert pipe into the threaded joint until the shoulder of the fitting is reached.
3. Tighten coupling nut manually and check tube position.
4. Attach screw wrench SW27 to sensor connection and tighten coupling nut with an adeqate tool with $1 \frac{1}{4}$ turns.
5. Check firm fit of the pipe.

Attention: Please ensure that no shear forces between the two pipe connections are created during mounting and operation.

Mounting the flow sensor housing

At the housing bottom there are four M4 threaded sockets with a depth of 5 mm. These can be used for mounting on a base plate etc. Alternatively it is possible to use the accessory mounting panel with the supplied screws for attachment to the sensor housing. This enables front mounting.

Maintenance

If operated in contaminated or calcareous water, deposits can build up, which may lead to measuring errors. Thus it may be necessary to clean the section of the sensor through which the liquid passes. The metal surface may not be damaged.

Operation

The inline flow sensors SS43 have front panel buttons for setting functions and displaying adjustments. All values are indicated via the 3-digit 7-segment display.

Button [S/-]: After a short press of the button, the set limit value for switch point S is indicated. In the programming mode, this button can also be used to decrease the indicated value.

Button [mA/+]: After a short press of the button, the actual current value in mA is indicated. In the programming mode, this button can also be used to increase the indicated value.

Button [FUNC]: After a short press of the button, the measured temperature value in °C is displayed for approx. 3 s. In the programming mode, this button can also be used to select functions and parameters.

Programming

To enter the programming mode, press buttons [S/-] and [mA/+] for at least 3s until the display starts flashing. For a short moment the character string [Cod] is displayed. Followed by the number [0], which can be modified according to the valid access code using buttons [S/-] and [mA/+]. Use button [FUNC] to select the required parameter. After selection, the parameter is displayed for approx. 2s, followed by the associated value which can now be modified. During entry it is automatically verified whether the set parameter is admissible. Two decimal points of the display will flash to warn against an invalid entry. To terminate programming and save all values press button [FUNC] for at least 3s until the display stops flashing.

	[Cod	0 ... 255	Enter acces code, factory setting: 0
1	USP	L oder °C	Unit switching point S (l/min oder °C)
2	SP	MIN +0,2 ... MAX oder -9... 90	Adjustable range switching point S (l/min or °C)
3	hs	02...2/5/10 oder 1... 10	Hysteresis switching point S (l/min or °C)
4	OU	n0 oder nC	Output S (Schließer / Öffner)
5	dS	00...500	Switch-on delay S (s)
6	dr	00...500	Switch-off delay S (s)
7	nF ₁	1 ... 8	Averaging (s)
8	GLY	0 5 10... 30	Selection of glycol content (%)
9	[AL		Display correction ± 25%
10	[Cod	0 ... 255	Modificaton of access code

Acces code [Cod]

Without entry of an access code it is not possible to set or modify device parameters. The ex factory setting is "0". This value can be modified at the end of the programming menu.

Unit of switching point S [USP]

The switching output S can be used for flow reate or temperature monitoring. Select [°C]] to activate temperature control. The value units depending on this switch point will change accordingly.

Switching point [SP]

The switch point S is entered in l/min, or, if required, in °C.

Hysteresis [hs]

The hysteresis is the difference between the switch-on value (which is identical to the programmed switch point S) and the switch-off value. It is entered in l/min, or, if required, in °C.

Output S

The switching output S can be adjusted either for the NO or NC mode.

Switch-on delay [dS]

If it is not required to update the output signal immediately after the switch point S has been exceeded, this value can be set in a range from 0...50 s. The signal will then only be updated after the set time has expired, provided the limit is still exceeded.

Switch-off delay [dr]

If it is not required to update the output signal immediately after the switch point S has been underranged, this value can be set in a range from 0...50s. The signal will then only be updated after the set time has expired, provided the limit is still underranged.

Averaging [nFi]

This parameter permits the entry of a value, which defines the time interval during which a measuring value average is formed. Values between 1...8 s can be entered. A low value will lead to a fast response, whereas a high value steadies the display of the measuring value.

Medium selection [GLY]

The flow sensor series SS43 is generally suited for monitoring water circuits. If a cooling circuit contains Glycol (monoethyleneglycol), then this specific contents can be entered as a percentage in increments of 5%. A possible measuring value deviation is thus compensated.

Reference function [CAL]

With this function, the displayed flow rate value can be modified by $\pm 25\%$. This can be useful in order to adapt the display exactly to a reference instrument.

Reset function

Use the RESET function to set all values back to the ex factory settings. For this, the device must be disconnected from power. Button [FUNC] is then pressed during re-connection. The character string [rES]power. Button [FUNC] is then pressed during re-connection. The character string [] is displayed. Then you will be prompted to enter the access code. Press [FUNC] to confirm the entry and carry out the reset.

Analog output

The analog output provides a current value that is proportional to the flow rate over the total detection range. Between 0 l/min and the minimum value of the detection range, the output value is 4mA.