

PT330570

LASER SENSORS • DIFFUSE REFLECTION SENSORS WITH BACKGROUND SUPPRESSION

Optical sensors function contactlessly. They detect objects independent of their characteristics (e.g., shape, color, surface structure, material). The basic operating principle is based on the transmission and reception of light. There are three different versions: 1. The through-beam sensor consists of two separate devices, a transmitter and a receiver that are aligned with one another. If the light beam between the two devices is interrupted, the switching output integrated in the receiver changes its status. 2. With the retro-reflective sensor, the transmitter and receiver are located in one device. The emitted light beam is reflected back to the receiver by a reflector that is to be mounted opposite the device. As soon as the light beam is interrupted, the switching output integrated in the device changes its status. 3. With the diffuse reflection sensor, the transmitter and receiver are in one device. The emitted light beam is reflected by the object that is to be detected. As soon as the receiver detects the reflected light, the switching output integrated in the device changes its status.



MECHANICAL DATA

Ambient temperature (MAX)	60 °C
Ambient temperature (MIN)	-10 °C
Degree of protection (IP)	IP67
Housing design	Cuboid
Housing material	Plastic ASA
Material of optical surface	PMMA
Reflector included in the scope of delivery	No
Sensor height	39.1 mm
Sensor length	23 mm
Sensor width	12.9 mm

ELECTRICAL DATA

Adjustment range (MAX)	250 mm
Adjustment range (MIN)	30 mm
Analogue output 0 mA ... 20 mA	No
Analogue output 0 V ... 10 V	No
Analogue output -10 V ... +10 V	No
Analogue output 4 mA ... 20 mA	No
Decay time	0.25 ms
IO-Link compatible	Yes
Laser power	1 mW
Max. output current	100 mA
Max. switching distance	250 mm
No-load current	30 mA
Number of pins	4
Number of switching outputs	1
Operating voltage (MAX)	30 V

ELECTRICAL DATA

Operating voltage (MIN)	11 V
Rated control supply voltage U_s at DC (MAX)	30 V
Rated control supply voltage U_s at DC (MIN)	11 V
Rated switching distance	250 mm
Reaction time	0.25 ms
Relative repeat accuracy	0.1 mm
Response time	0.25 ms
Reverse polarity protection	Yes
Scanning function	Light-/dark-on mode
Sensing range (MAX)	250 mm
Sensing range (MIN)	15 mm
Setting procedure	Teach-In
Short-circuit-proof	Yes
Switching frequency	2000 Hz
Type of electrical connection	Connector M8
Type of switching function	Normally closed contact/normally open contact
Type of switching output	PNP+NPN
Voltage drop	2.5 V
Voltage type	DC
With LED display	Yes
With LED display (functional reserve)	Yes
With LED display (operation)	Yes
With LED display (signal)	Yes
With LED display (teach)	Yes
With other analog output	No

OPTICAL DATA

Background suppression	Yes
Laser class	1
Laser focus distance	80 mm
Laser protection class	Class 1
Light beam form	Point
Light source	Laser diode, red light
Triangulation	Background suppression
Wavelength of the sensor	650 nm

CONNECTION

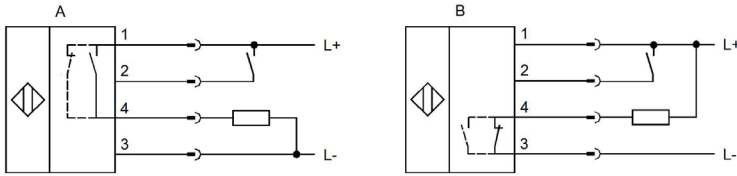

Colors: A: 1 = BN (brown), 2 = WH (white), 3 = BU (blue), 4 = BK (black)

B: 1 = BN (brown), 2 = WH (white), 3 = BU (blue), 4 = BK (black)
Functions: A: 1 = L+, 2 = teach-In, 3 = L-, 4 = PNP NO PNP NC

B: 1 = L+, 2 = teach-in, 3 = L-, 4 = NPN NO/NC

DIMENSIONAL DRAWING

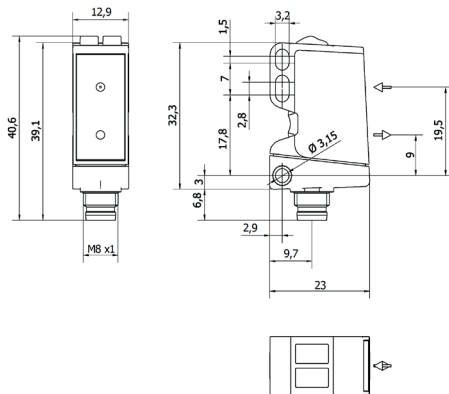

INSTALLATION



Mounting / Installation may only be carried out by a qualified electrician!

DISPOSAL



SAFETY WARNINGS

Before initial operation, please make sure to follow all safety instructions that may be provided in the product information!

Never use these devices in applications where the safety of a person depends on their functionality.