

MZA72176

MAGNETIC SENSORS • SENSORS FOR PNEUMATIC CYLINDERS

sensor magnetic, cylinder, 6.2mm T-groove, 4,3x19x6,2mm, 10-30V DC, 1x PNP NO, Cable connector M8 3pin 0.3m PUR (Polyurethane), IP67, Zinc die-cast, LED, 2.8mT, mounting From the top, Sensor surface position Center of the device



MECHANICAL FEATURES

| | |
|---------------------------------------|----------------------|
| Ambient temperature | -25 °C ... 70 °C |
| Cable length | 0.3 m |
| Degree of protection (IP) | IP67 |
| Design | Cuboid |
| Housing material | Zinc die-cast |
| Increased ambient temperatures > 80°C | - |
| Material of cable sheath | PUR (Polyurethane) |
| Max. tightening torque | 0.1 Nm |
| Metal housing | + |
| Mounting access, cylinder groove | From the top |
| Sensor height | 4.3 mm |
| Sensor length | 19 mm |
| Sensor surface position | Center of the device |
| Sensor width | 6.15 mm |
| Strong vibration / motion | + |
| Version | 6.2mm T-groove |

ELECTRICAL FEATURES

| | |
|---|---------------|
| Cross/short circuit identification possible | - |
| Low sensitivity | - |
| Low switching hysteresis | + |
| Magnetic sensitivity | 2.8 mT |
| No-load current | 15 mA |
| Number of pins | 3 |
| Number of switching outputs | 1 |
| Operating voltage | 10 V ... 30 V |
| Rated switching current | 150 mA |
| Reed contact | - |
| Relative repeat accuracy | 0.1 mm |
| Reverse polarity protection | + |
| Sensor surface (active) | Middle area |
| Setting via teach-in | - |
| Short-circuit protection | - |

ELECTRICAL FEATURES

| | |
|--|-----------------------|
| Suitable for safety functions | - |
| Switching frequency | 1000 Hz |
| Two switching points | - |
| Type of electrical connection | Cable connector M8 |
| Type of switching function | Normally open contact |
| Type of switching output | PNP |
| Voltage drop | 2 V |
| Voltage type | DC |
| With LED display | + |
| With monitoring function of downstream devices | - |

OTHER FEATURES

| | |
|--------------------------------|---------------|
| Cylinder sensors | + |
| Cylinder version | With T-groove |
| Harsh environmental conditions | + |
| Metallic sensor surface | - |
| Oil and cooling lubricants | + |
| Short travel path | - |

Other

| | |
|----------------------|------------------------|
| Packaging dimensions | 100mm x 17.0mm x 120mm |
| Shipping weight | 0.01kg |
| Tariff code | 85365019 |

Classification

| | |
|-------------------|----------|
| ipf product group | 221 |
| eClass 8.0 | 27270105 |
| eClass 9.0 | 27270105 |
| eClass 9.1 | 27270105 |
| ETIM-5.0 | EC002544 |
| ETIM-6.0 | EC002544 |
| ETIM-7.0 | EC002544 |

Connection

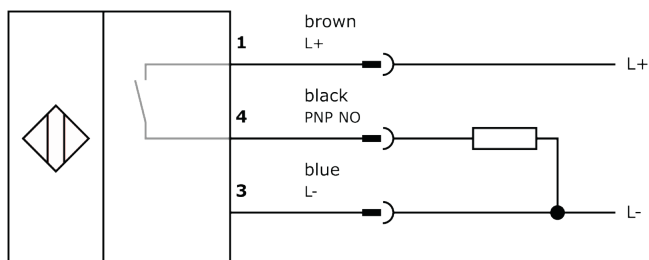

Dimensional drawing

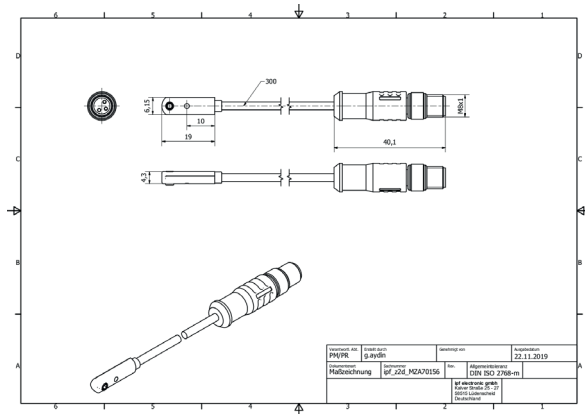

Installation



Mounting / installation may only be carried out by a qualified electrician!

Disposal



Safety warnings

Before initial operation, please make sure to follow all safety instructions that may be provided in the product information. Never use these devices in applications where the safety of a person depends on their functionality. LED lighting systems can generate intensive UV radiation, which can damage your eyes in case of improper use. The manufacturer cannot be held responsible for damages that result from improper use or connection.